

Gesture Controlled Robotic Vehicle

A Technical Report submitted to the Department of Electrical and Computer Engineering

Presented to the Faculty of the School of Engineering and Applied Science
University of Virginia • Charlottesville, Virginia

In Partial Fulfillment of the Requirements for the Degree
Bachelor of Science, School of Engineering

Nima Razavi

Spring 2024

Technical Project Team Members

Ruhul Quddus

Goutham Mittadhoddi

Ian Le

Kenny Zhang

On my honor as a University Student, I have neither given nor received unauthorized aid on this assignment as defined by the Honor Guidelines for Thesis-Related Assignments

Adam Barnes, Department of Electrical and Computer Engineering

Table of Contents

Table of Figures.....	3
Statement of Work.....	4
Abstract.....	5
Background.....	5
Societal Impact Constraints.....	6
Physical Constraints.....	7
External Standards.....	8
Intellectual Property Issues.....	8
Project Description.....	9
Timeline.....	17
Costs.....	20
Final Results.....	21
Future Work.....	22
References.....	23
Appendix.....	25

Table of Figures

Figure 1: Glove Component Layout	11
Figure 2: Car Component Layout	11
Figure 3: Video Display Component Layout	12
Figure 4: Overall System Layout	12
Figure 5: Car Port Map Diagram	13
Figure 6: Glove Port Map Diagram	14
Figure 7: Schematic of Glove PCB	16
Figure 8: Schematic of Car PCB	16
Figure 9: Gantt Chart	18
Figure 10: Gantt Chart (cont.)	18
Figure 11; Gantt Chart (cont.)	18
Figure 12: Gantt Chart (cont.)	19
Figure 13: Changes made to Gantt Chart	19
Figure 14: Changes made to Gantt Chart (cont.)	20
Appendix 1: Budget Outline	25

Statement of Work

Ruhul Quddus: I was in charge of pretty much everything. I have worked on and have supported others on almost every single task. But the things I spent most of my time on were designing the PCB's, getting the bluetooth connection working, integrating the glove and the car together, and rigorously testing every single feature of our project. Additionally, I acted as a "project leader" to our team maintaining a schedule and having deadlines for tasks, making critical design decisions, and constantly staying on top of things.

Nima Razavi: I was in charge of parts selection and placing parts order. I assisted with circuit design with Ruhul. I managed the parts needed for the PCB and how the breadboard circuits will be reconstructed efficiently on our PCB. I was in charge of soldering both PCBs. I also was the lead for the camera and managed the Gantt chart for the team. I implemented the Bluetooth connection code when we decided to move away from Wifi as our method of glove to car communication. I was responsible for the 3D printing and sizing of the 3D printed boxes to hold the PCBs.

Goutham Mittadhoddi: I was in charge of programming the glove and the car. I worked on processing the sensor data from the glove and formatting it to send to the car. In the car I made sure the data was processed correctly to produce the correct movements. I also helped Ruhul with circuit design and Nima with soldering and assembly.

Ian Le: I was in charge of the 3D modeling as well as assisting with programming parts of the car. I implemented Bluetooth communication between the Pico boards. For 3D modeling I modeled boxes for each component as well as modeled brackets for both the ultrasonic and camera. Finally, I assisted with general construction by helping solder and buy glove materials.

Kenny Zhang: I was in charge of various bits of programming on the glove and car. I aided Ian and Nima on implementing the bluetooth communication between the Pico boards. I also reformatted the codebase and set up source control for the project. In the later half of the project, I spearheaded the development of the backtracking algorithm and disconnect handling.

Abstract

This project is a gesture controlled robotic vehicle for use by teenage tech enthusiasts. There are two components to this project: a glove that tracks the hand gestures of the user and a robotic car which the user is controlling. The glove takes in gyroscope data from an MPU6050 sensor placed on the glove on the back of the palm. A Raspberry Pi Pico W on the glove transmits the sensor information wirelessly using the Pico's built in Bluetooth capabilities to the other Raspberry Pi Pico W on the car. The glove has a small vibration motor that vibrates with different frequencies based on the ultrasonic sensor's object detection capabilities that is attached to the back of the car. This acts like a haptic feedback system for the user to get an idea regarding the car's surroundings. The glove also has a hall effect sensor to it and users can use their fingers to trigger the hall effect to go into a different modes: orientation lock and unlock modes. In orientation lock mode, the car will spin turn and in orientation unlock mode, the car will strafe sideways. The car has four 12V DC brushed motors along with four mecanum wheels, and each of the motor controllers is driving two of the mecanum wheels through Pico's commands. The car also has an analog camera on it so that the user can drive the car through a monitor with HDMI display. The glove will be powered by a 9V battery, while the car will be powered by a 9V and 12V batteries. Furthermore, both the glove and the car have its own PCB that is driving power and connecting everything. This project is designed to have all components on the glove fit comfortably in the limited surface area of the hand. All components are readily available and easy to manufacture, making the project fit for mass production. The low cost of components will allow the car to be sold for reasonable prices to similar toys.

Additional components can be integrated to enhance user experience.

Background

Society is entering an age where humans and robots work as one. Over the past decade, interest in applied robotics has grown significantly. Rapid advancements in hardware design and firmware platforms have enabled the creation of advanced robotic systems able to cooperate with humans in both home and industrial environments. However, inspiring the next generation of young engineers is critical for the continuous advancement of science and technology. Currently, many efforts are being taken to foster youth interest in robotics in interactive ways outside the traditional classroom [1]. Doing so not only instills youth interest in engineering careers, but also improves teenagers' problem solving and technical skills. In fact, many present-day high-school robotics competitions revolve around solving real world problems by having students design complex robotic systems while acting as robot teleoperators, such as the FIRST robotics competition. Thus, our project will contribute to this growing interest by creating a gesture-driven robotic vehicle marketed towards STEM-interested teenagers. Although this project does not address any real-world problems, it enables teenagers to explore applied robotics by providing a fun and approachable entry point for developing interest.

Engineers at the Rajiv Gandhi Institute of Technology completed a similar project, where they built a robotic vehicle that was controlled via hand motions [2]. In their design, they mounted an accelerometer to a controller on the user's hand that could take in yaw, pitch, and roll. The accelerometer was then connected to an RF transmitter module responsible for sending the rotational data to an RF receiver on the robot. Once the data was received on the robot end, it was then sent to a microcontroller that translated the data into a motion command, such as moving forwards, backwards, and turning. Additionally, the

engineering team mounted ultrasonic sensors onto the robot and programmed an obstacle detection system onto the microcontroller.

This fundamental design for gesture-driven control is also present in more involved projects. In one project presented at the International Conference on Nascent Technologies in Engineering (ICNTE), engineers presented a similar hand-motion controlled robotic car that could additionally be toggled between automatic movement and gesture-driven movement [3]. Moreover, engineers at the ISL Engineering College applied this idea further by designing a gesture-driven grass cutting vehicle powered by solar energy [4]. All these adjacent projects feature a similar fundamental design: mounting an accelerometer or gyroscope on the user's hand and transmitting the data over an RF module to be translated by the vehicle.

Although our project is similar in concept, it differs in a few key areas. For one, this product focuses much more attention on the user-control side of the project. Rather than using a single, rigid device, the controller glove is both modular and visually appealing. Specifically, the glove features a gyroscopic sensor for controlling the speed and rotation of the car, as well as a vibrational motor for haptic feedback. Furthermore, a hall-effect sensor, mounted on the thumb, is responsible for toggling the car into orientation-lock mode. This operation mode allows the car to perform strafing movements rather than left or right spinturns. Another key design decision for our project is the data transmission protocol. Rather than designing dedicated RF transmitters and receivers, the glove and car will be transmitting data via several bluetooth sockets between two Raspberry Pi Pico W's. Because these microcontrollers have bluetooth modules [5], this design decision cleanly integrates the wireless communication with the rest of the embedded software. Finally, this project implements several auxiliary features, including haptic feedback, camera functionality, different driving modes, and backtracking. Further details about the project design will be discussed in a later section.

This project will utilize an accumulation of knowledge across several Electrical and Computer Engineering courses. First, core concepts from Introduction to Embedded Computer Systems (ECE 3430) and Embedded Computing and Robotics (ECE 3501, 3502) were utilized to guide microcontroller programming and sensor-microcontroller communication (I2C). Circuits and electronics knowledge from ECE Fundamentals I, II, and III (ECE 2630, 2660, 3750) will also be required for the glove and robot PCB designs. For the glove-robot communication, basic networking concepts from Computer Networks (CS/ECE 4457) will be useful. Finally, on the software side, this project required fundamental knowledge from Advanced Software Development Techniques (CS 3240), Program and Data Representation (CS 2150), and Data Structures and Algorithms 2 (CS 3100).

Societal Impact Constraints

The goal for the system is for it to be usable to a wide range of ages. The product is aimed at the 11–15-year-old age group therefore the product must be comfortable and intuitive to use, but not without a learning curve to keep the user engaged with our product. The product is constructed to handle moderate amounts of stress. As a consumer entertainment device, the ethical considerations of our product are low. Some ethical considerations are the primary demographic of our product. With a gesture-based control system, only those of able body will

be able to use our product. Our product is aimed at the “tech-enthusiast” demographic which is a male dominated group with disposable income. Our product will aim to be agnostic to gender roles in marketing and presentation, as well as affordable for as many demographics as possible.

Another consideration considered is the onboard camera included on our vehicle. This poses privacy concerns due to the potential for our product to be used for spying or surveying. However the low power motors and mecanum wheels our vehicle is only suited to completely flat surfaces. In addition, the relatively low range of our bluetooth connection (about 100 feet) prevents the operator from being too far away from the vehicle. Because this project uses an analog transmitter and receiver, our camera feed is unencrypted. This poses some serious privacy issues if it eventually enters the market. If our project eventually becomes a consumer product this must be addressed.

Finally, due to the construction of our vehicle being mostly plastic and other electronic parts there are concerns due to disposal of our vehicle. The 3D printed components are made from PLA, which is biodegradable under the right conditions and can also be broken down and reused. The circuit boards and other electronic components are much more difficult to recycle and will contribute to e-waste once disposed of. During the manufacturing process other factors such as energy expenditure to create both the product and packaging as well as to recharge batteries will contribute negatively to the environment.

Physical Constraints

The largest cost constraint to turning this prototype into a product produced on a larger scale is the video transmission feature of the project. The rest of the electronics for the project are mostly widely available and fairly inexpensive. However, since it is a separate product that is dropped into this project, the camera/transmitter is more expensive and may have less availability than the mass produced and generic components used in the rest of the project.

The display of the video also presents a complication in turning it into a product. Each product would have to come with a receiver and HDMI converter to be able to see the video output. Since these are also separate products that were dropped into the project, they are more expensive and have more restricted access. While the PCBs in the prototype can be improved by decreasing their size and expense, these drop in elements would be a limiting factor in lowering the price and size of the product.

Other than the standard lab equipment such as a soldering iron and multimeter, this project required a 3D printer, a rotary tool, sewing needles, and a grommet kit. The 3D printer was used to construct casings for the sensors and Raspberry Pi Pico W's. The rotary tool was used to modify the 3D prints to ensure they fit the sensors and Picos. The sewing needles were used to modify the glove to house the sensors. The grommet kit was used to modify the glove to manage cables connecting the sensors and motor to the PCB.

The primary software development tool was the Thonny 4.1.2 IDE [6]. It is made to interface with the Raspberry Pi Picos with Micropython. It aided in installing Micropython [7] onto the Picos, easily reading serial output, and uploading code to the Picos. The primary software tool for PCB design and simulation was KiCad 7.0.8 [8]. It aided in building theoretical models of our circuits and easily converting them into PCB designs.

External Standards

As the product is made of plastic and other inorganic material, there is difficulty in recycling our product. However, our product could be repurposed as an educational project if the user wishes. By reprogramming the microcontrollers, our product could be used to teach robotics and programming concepts.

Our product will need to be certified by Standard Consumer Safety Specification for Toy Safety (ASTM F963-17) [9] which outlines a set of safety standards for toys sold in the United States. Our project will have considerations to the following sections:

- 4.1 Material Quality: Ensure that the materials used do not contain toxic chemicals.
- 4.7 Accessible Edges: Ensure that there are no sharp edges on the product
- 4.10 Wires or Rods: Ensure that wires are safe and do not produce sharp edges when cut.
- 4.17 Wheels, Tires, and Axles: Ensure pieces do not present a choking hazard.
- 4.18 Holes, Clearance, and Accessibility of Mechanisms: Make sure that mechanical systems are properly shielded, and safety mechanisms are properly accessible
- 4.25 Battery-Operated Toys: Ensure batteries are ANSI C18.1 conformant, battery terminals are clearly marked and under a maximum of 24V.
- 5 Labeling Requirements: Ensure that labels are accurate and appropriate
- 6 Instructional Literature: Ensure that directions are provided for correct usage of product.
- 7 Producer's Markings: Product must be labeled correctly and supplied a model number
- 8 Test Methods: Product must undergo testing to verify conformance to ASTM F963-17
- Annex A1 Age Grading Guidelines: The product must be appropriately labeled for the correct age grade.
- Annex A2 Packaging and Shipping: Product must conform to correct packaging and shipping guidelines
- Annex A8 Design Guidelines for Battery Operated Toys: Product must have considerations for battery failure or ingestion

Intellectual Property Issues

Three US patents were found encompassing similar material to our project. The first is called “System and method for controlling swarms of remote unmanned vehicles through human gestures” (US8214098B2) [10]. This patent is relevant because it describes a process for controlling one or multiple unmanned vehicles through human gestures, and comprises of 3 independent claims and 17 dependent claims. Specifically, dependent claims 2-15 cover the operation of a remote, unmanned vehicle through the movement of different body parts, including the head, hands, and torso. Our project might be patentable despite these claims because the product focused on the complete, salient control of a vehicle through only hand gestures. Additionally, our project scales the power of the robotic vehicle depending on the angle of the gestures.

The second similar patent found was “Gesture input system and gesture input method” (US20140143738A1) [11], which consists of 2 independent claims and 15 dependent claims. Specifically, claim 29 of the patent (claims 1-28 were canceled) covers interpreting a set of gestures and mapping them to a set of actions defined within a digital system. Although this patent covers a similar gesture reading and gesture mapping system to our project, the system

that is being controlled is completely different. In this patent, the mapped actions control a digital system for managing message streams within an application interface. However, our project uses gesture interpretation to control a wheeled, robotic car system meant for teleoperation purposes.

The last patent found covering similar material was “Systems, methods, and apparatus for controlling gesture initiation and termination” (US9965169B2) [12]. This patent consists of 4 independent claims followed by 26 dependent claims, and is relevant because it also introduces an apparatus in a vehicle to act as a gesture detection device. The main vision of this patent as described in claim 10 is to detect the hand gesture, receive a button push to indicate that the gesture has been completed, determine the intended command based on the gesture and button selected, and output the command requested. In contrast to our project where the gyroscope on the glove is measuring the X and Y rotation of the hand to act as the source of the input to the desired commands of the user, this patent, according to claim 23, requires a device to visually interpret a hand gesture in combination with a button press to result in a command being executed. Although our project employs a similar concept, we believe it is patentable in light of these claims due to the data transmission mechanism. While this patent uses image detectors to process hand gestures, our project sends a data stream of tilt angles directly to the robot over a bluetooth connection, in which the robot then performs vector computations to translate into motion.

Project Description

How it works

The proposed project is a gesture-driven robot car. This takes the classic remote control toy car and elevates the user’s experience by making the controls more intuitive and adding video and haptic feedback from the car.

The glove will have a MPU 6050 gyro sensor, a hall effect sensor, two magnets, a vibration motor, a Raspberry Pi Pico W, a custom PCB, and a battery. The gyro, Pico, and battery will all be connected to the custom PCB and will be placed on the back of the hand. The gyro on the back of the hand will measure the pitch and roll of the hand and send it to the car as x and y movement data.

The hall effect sensor, magnets, and vibration motor are attached to the inside of the glove near the user’s fingertips. The hall effect sensor at the tip of the thumb determines which mode the car is in. When the sensor’s output is low the car drives forward and backward with turning to change heading. When the output is high, the car enters orientation lock mode where it strafes left and right rather than change its heading. The sensor latches the output so that when the north pole sets the output high, the output remains high until the hall effect is exposed to a south pole. The two magnets in the index and middle fingertips have opposing poles to be able to switch the sensor output. This ensures that the user does not need to continuously hold their finger to the sensor to hold a mode. Finally there is a haptic motor in the right fingertip that pulses as the ultrasonic sensor on the car approaches an obstacle.

The custom PCB on the glove connects all of the sensors and outputs to the Pico. The Pico accepts data from the gyro via I2C [13], reads a high or low voltage from hall effect, and drives the motor with a PWM signal. The PCB has an amplifier circuit that maps the 0.5V high output of the hall effect to a 3.3V high that can be detected by a GPIO pin. It contains a motor

controller that maps the PWM signal from the Pico to pulse the haptic motor. The PCB also houses a power supply circuit that connects to the battery to ensure that all of the components have the appropriate voltage and current.

The car will have a Wolfwhoop WT03 Micro FPV AIO 600TVL camera with an adjustable transmitter, HC-SR04 ultrasonic sensor [14], four TT motors with Mecanum wheels, two L298N motor controllers [15], a Raspberry Pi Pico W, a custom PCB, and two batteries. The Pico on the glove is connected to the Pico on the car via a Bluetooth connection. The x and y movement information provided by the gyro of the glove is transmitted to the car where it is interpreted as instructions that drive the car's movements. Based on the instructions, the Pico on the car sends signals to the motor controllers to send appropriate voltage to each motor independently. While the car is moving, it collects information about its environment through the camera and ultrasonic sensor. The camera is placed facing forward on the car so the user can see from the car's point of view. The ultrasonic sensor is placed backward on the car to sense objects as they approach the car from behind. The information from the ultrasonic sensor is sent back to the glove via the Bluetooth connection. This information is used to send signals to the motor controller that drives the haptic feedback vibration motor in the glove. This allows the user to feel objects outside of the camera's view. The camera has an analog transmitter that sends data to a Wolfwhoop WR832 5.8GHz 40CH Wireless FPV Audio Video receiver near the user. This data passed through a BD&M AV to HDMI converter that can output to any HDMI monitor. The custom PCB on the car serves to supply power to all the components.

The car is also equipped with a backtracking algorithm that will activate whenever the glove disconnects or if the car drives outside of bluetooth range. The car maintains a global queue with a sliding window size to track the most recent N gyro data entries. Once the car begins receiving gyro data from the glove, it appends the negation of the incoming data at a fixed sampling interval if the data is nonzero. If the queue reaches maximum capacity, it will begin left shifting to maintain the most recent data entries. The sliding window size and sampling period are adjustable system parameters that may be used in future testing. Generally, a larger sampling period offers less precision, but a longer history, while a smaller sampling period offers more precision, but a shorter history. Upon disconnecting, the car code then calls a disconnect handler to reverse trace the queue and, upon completion, stop the car's motion. This sequence allows the car to return to a position within bluetooth range, where the user can regain control of the vehicle by cycling the power on the glove.

Glove

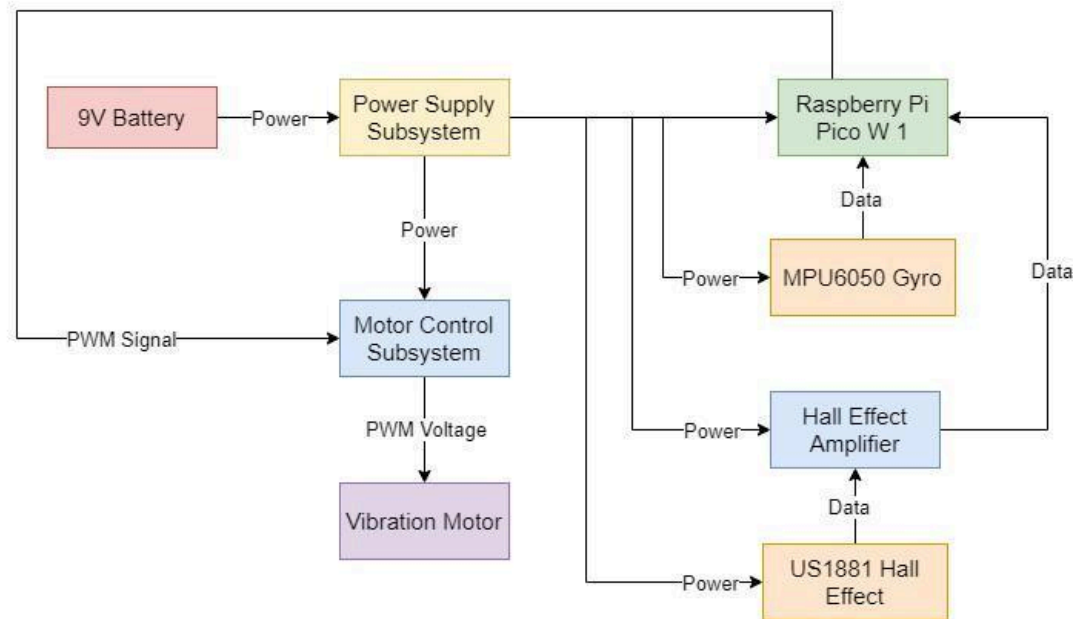

Figure 1: Glove Component Layout

Car

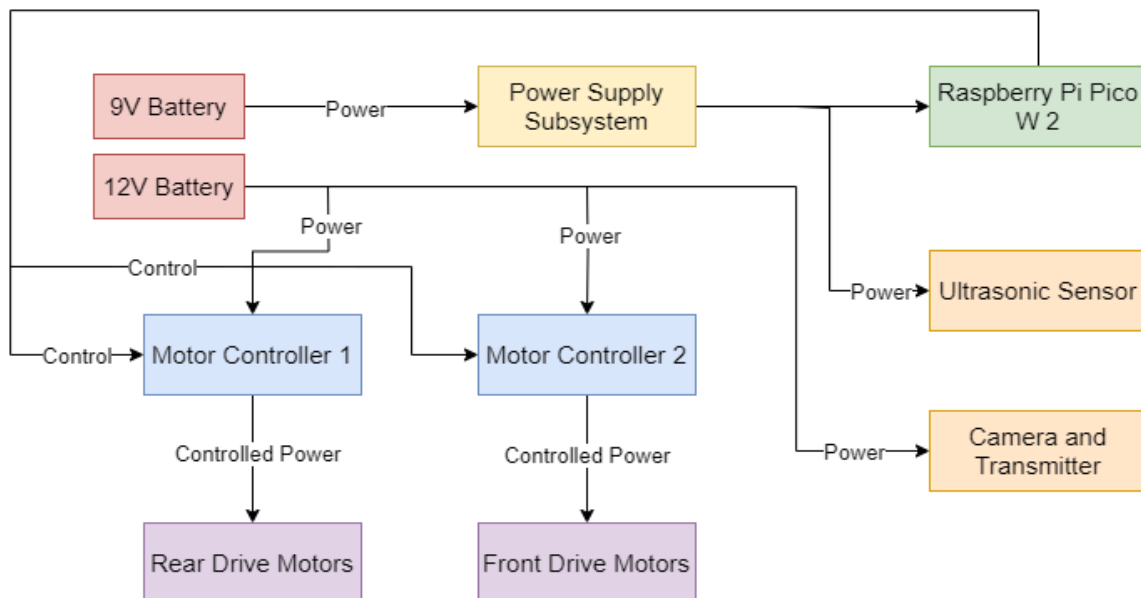

Figure 2: Car Component Layout

Video Display

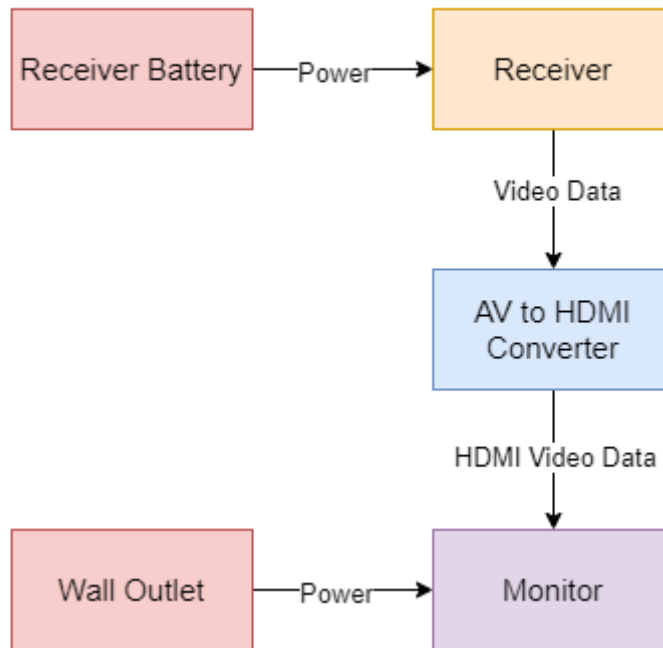

Figure 3: Video Display Component Layout

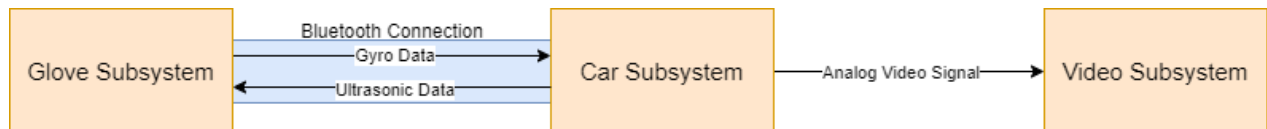

Figure 4: Overall System Layout

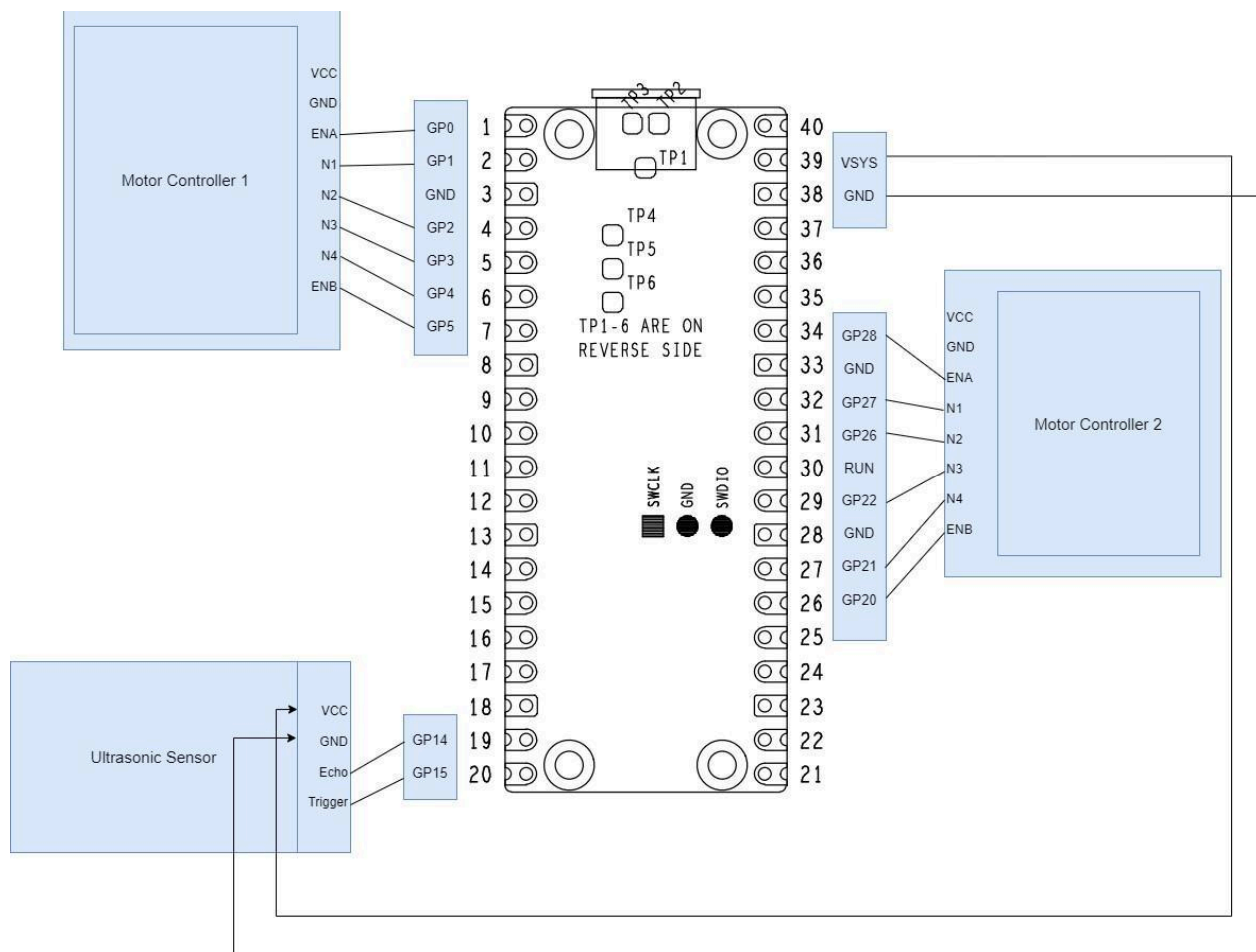

Figure 5: Car port map diagram

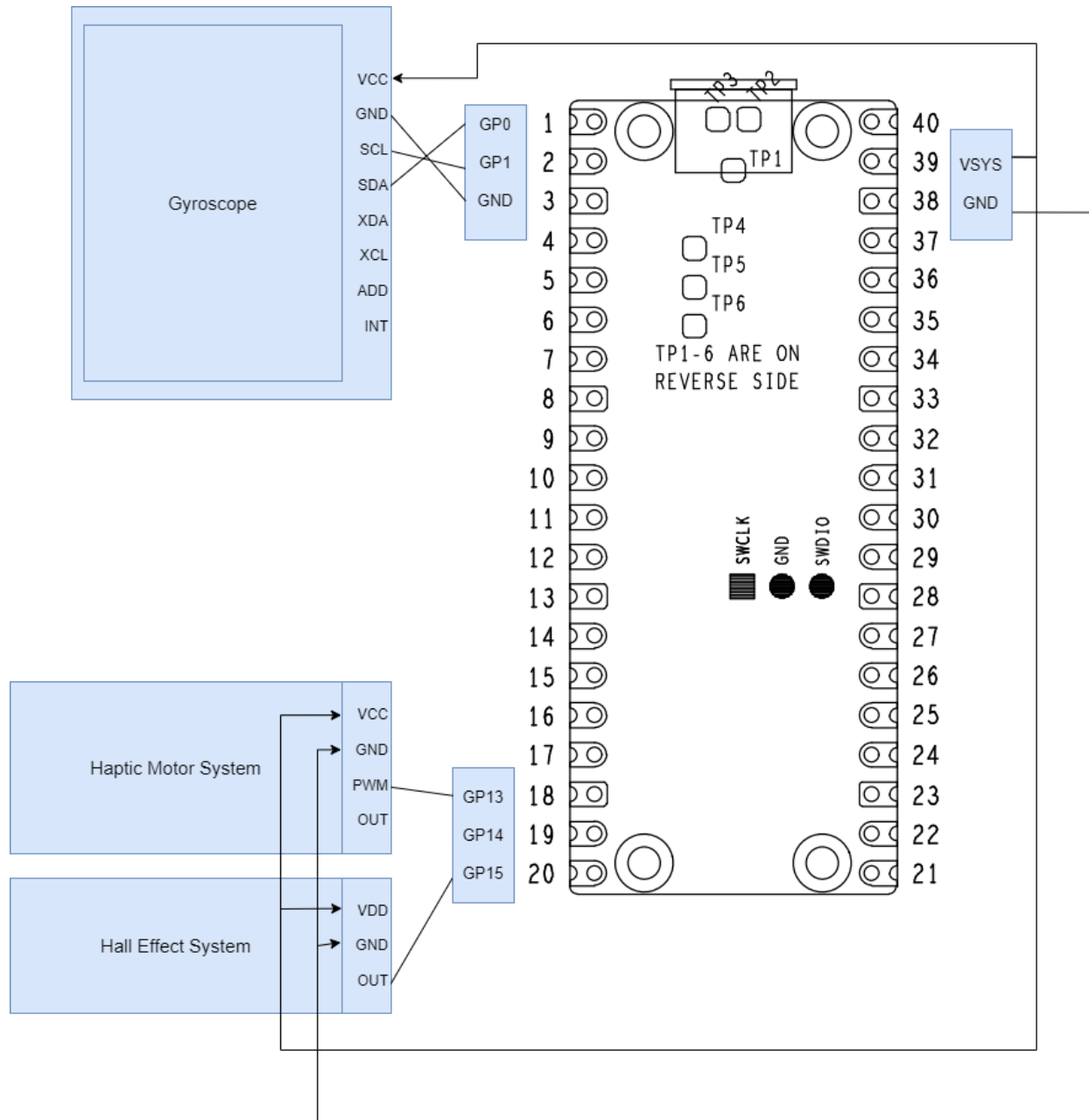

Figure 6: Glove port map diagram

Design Decisions

The Raspberry Pi Pico W was chosen for two main reasons: its size and wireless capabilities. Compared to most microcontrollers, the Raspberry Pico is very light weight and small, making it easy to fit onto the back of a hand. Unlike the STM32 and the MSP430, the Raspberry Pico has “on board single band 2.4 GHz wireless interfaces (802.11n, Bluetooth 5.2)” [5]. Additionally, the serial connections available on the Pico allow it to interact with a wide range of peripheral devices. The 3.3V output on its 16 PWM channels can power the haptic

motor. The dual-core cortex M0+ processor can support the necessary processing power for our project.

The MPU6050 is “arguably the most popular MEMS accelerometer used for Raspberry Pi and Arduino” according to one IoT hobbyist [13]. The MPU’s datasheet notes that the MPU is necessary for “gesture commands for applications ... phone control ... and enhanced gaming” [16]. For the product, the Raspberry Pico used has two separate I2C buses [5]. Since the product only uses one MPU6050 sensor, there are enough channels for it to communicate with the Pico. Overall, the MPU chosen provides both gyrosopic and accelerometer data needed to accurately measure the user’s hand’s orientation to drive the car. A complementary filter design aids in using the gyroscope feature and is proven for tracking gestures as needed for our project [17]. A haptic feedback motor is attached in our glove so that a user wearing the glove can detect feedback from the car. Since the purpose of the motor is to just vibrate (not to move any objects) a DC vibration motor from PUI Audio Inc. [18] was chosen.

For this project, difficult decisions were to determine what degree our components are purchased rather than manufactured by us. The team concluded that the focus of this project is the glove. The main goal is to capture movement data from the glove and represent that data in the real world. As the car is just a representation of the glove’s data capture capabilities, the team decided to put less effort into its design and construction by using preexisting car kits. The car is from the DWWTKL DIY Mecanum Wheel Car Kit. The kit comes with an aluminum chassis, four TT motors, four mecanum wheels, and the hardware necessary to assemble the chassis. Salvaged parts from a used Elegoo Uno R3 Project Smart Robot Car Kit V3.0 were also used initially. The kit comes with a variety of cables, sensors, motors, and an Arduino. For this project, however, the ultrasonic sensor was the only component used from the kit and the motors were used as replacements. Two HiLetgo L298N motor controllers [15] were bought in order to independently control each motor independently.

A drop in camera was utilized instead of a camera designed for the Raspberry Pico due to the Pico not having enough RAM to transmit live video frames at a high enough resolution to be meaningful to the user. The Wolfwhoop WT03 Micro FPV AIO 600TVL Camera was the camera chosen. This is an analog video transmitter and takes up very little space on the car. The processing for the video is completely independent of the Raspberry Pico. The receiver for the camera outputs RCA but with a converter it can output HDMI. The drop-in camera chosen requires 5V and 300mA so it can be powered from the 9V battery with a buck converter.

For the power supply PCBs, a variety of regulators and converters were used to ensure power is properly distributed among the systems. In the glove a 3.3V 1.5mA voltage regulator [19] was used to power all of the devices. The current will be divided across the Pico, an MPU6050 sensor, a hall effect sensor, and a haptic motor. In the car, there are two separate voltage sources. The first is a 9V battery. It powers a 5V 1.5A [20] as well as a 3.3V 1.5mA [19] voltage regulator. The 3.3V regulator is used to power the Pico while the 5V powers the ultrasonic sensor. An additional 12V battery was incorporated on the car. This battery directly outputs into the motor controllers. It also powers a 5V 2A buck converter [21] that supports the drop in camera and transmitter. To prevent overcurrent issues, current limiting resistors were added to ensure each branch can safely handle the current load from the buck converter.

Glove PCB

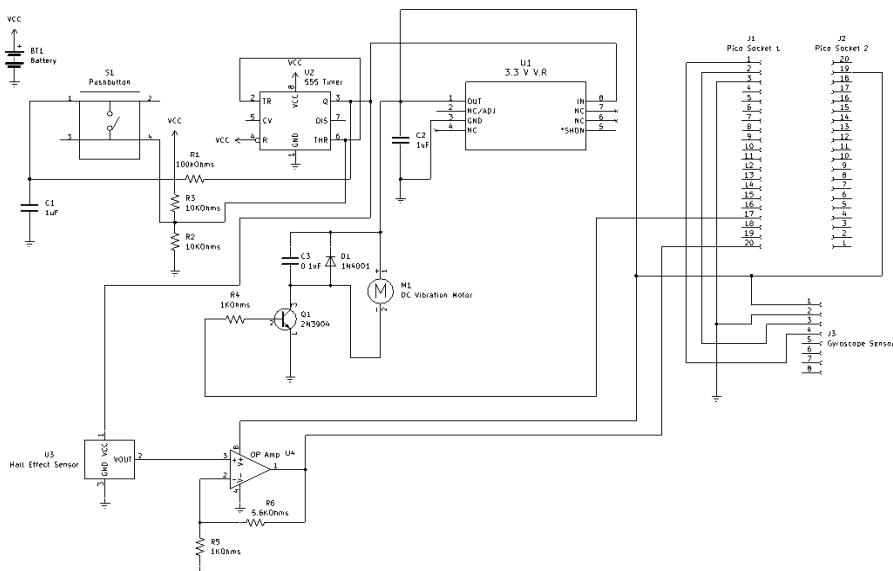

Figure 7: Schematic of Glove PCB.

Car PCB

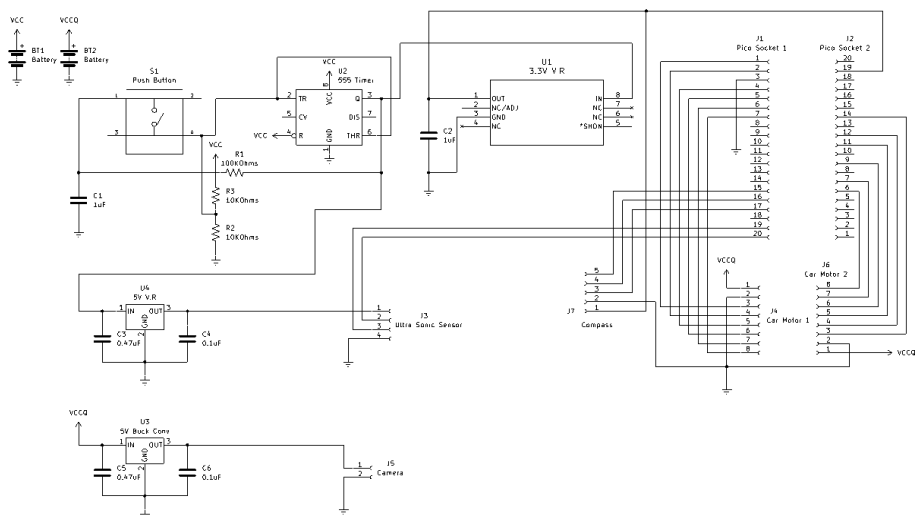

Figure 8: Schematic of Car PCB.

Test Plan

Since this project is modular in nature, it is relatively simple to test its subsystems. First, each sensor was tested with a Pico one at a time using an external power source. At this stage, unit tests were coded to be able to ensure the functionality of the sensors in the future as the tests grow more complicated. The components of the project were later tested using a limited power supply on bread boards.

The design for the entire power supply circuit was finalized on a breadboard to ensure all the devices can be powered. This allowed us to test programming the parts of each module in parallel. Once the PCB was designed and shipped, each subsystem was tested individually to ensure enough power is safely delivered. For instance, the ultrasonic sensor on the car can be individually powered and tested first on the car followed by the Pico and other components before the entire car's power supply board is powered. Once the glove and car were powered and data was received independently, Bluetooth connection was tested between the two modules both when the components are powered by the breadboard and the PCB.

To test the project as a whole, the test environment was made to be similar to our use environment. Since the project is intended to be used as an indoor toy, testing was done on the linoleum flooring of the capstone room as well as the carpet of the student lounge. In both of these environments, limitations of the range of motion of the user's hand were identified and adjustments were made to the sensitivity of the movement detection. Motor power imbalances that caused drift in the robot were identified and mitigated to the best of our ability. For the backtracking algorithm, the accuracy of the reverse movements were detected and fine-tune measurements of the timing of the disconnect handler were added to account for deviations. Furthermore, the team successfully tested the backtracking activation by both manually disconnecting the glove using the pushbutton and bringing the components outside the bluetooth range of each other. Overall, the team was able to get all project components working with each other during the final integration tests.

Timeline

The Gantt chart provides a list of tasks that need to be done individually and collectively as a team. This chart helps illustrate what tasks can be done in parallel. All project goal dates are listed along with individual task deadlines.

The proposal Gantt chart was followed closely for the first two months of the semester. In the first weeks of September, experimentation was done with the Raspberry Picos to establish communication to the gyroscope, establish a coding environment for editing the Picos, and finalizing design decisions. By the end of September, reliable sources of power were provided to power the motors, ultrasonic sensors on the car, and the Bluetooth communication between the car and glove Picos was established. By the poster session in early October, a working demo of the motors responding movements by another Pico for the glove was complete. The car at this point could also change to different drive modes using magnets to toggle the hall effect sensor [22].

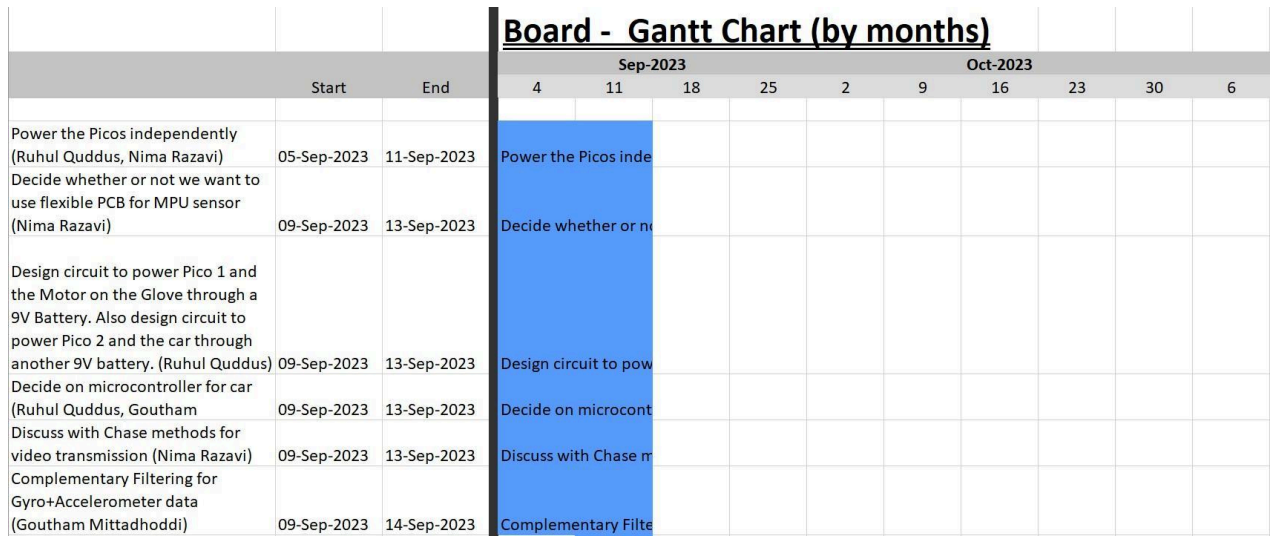

Figure 9: Gantt Chart from proposal (same as final Gantt Chart)



Figure 10: Gantt Chart from proposal (same as final Gantt Chart) cont.



Figure 11: Gantt Chart from proposal (same as final Gantt Chart) cont.

Integrating the ultrasonic sensor on the car with motors running (Ruhul Quddus)	06-Oct-2023	10-Oct-2023							Integrating the ultras
Have a demo of glove wirelessly controlling car's motor and ultrasonic sending feedback to glove for poster session (Nima Razavi, Ruhul Quddus, Goutham Mittadhoddi, Ian Le, Kenny Zhang)	07-Oct-2023	11-Oct-2023							Have a demo of glove
Test the 5 V 1.5 A Regulator (Nima Razavi)	08-Oct-2023	10-Oct-2023							Test the 5 V 1.5 A Reg

Figure 12: Gantt Chart from proposal (same as final Gantt Chart) cont.

After the poster session, there were some deviations from the proposal Gantt chart. Because the team had anticipated finishing the functional requirements of the car in early November, more project goals were added. A metal chassis and new motor controllers were bought to replace a pre-assembled kit for the car originally had for testing. Additionally, as shown in Figure 13, the time needed to create the PCB in KiCAD took longer than expected. After receiving the PCB and performing tests in early November, more changes to the car's PCB were made. The size of through holes were increased, power routings were redirected, and a connection was added for a digital compass module. The addition of the compass resulted from efforts to remove drifting of the car. The drifting was not a dramatic impact on the performance but the team had time in the schedule to perfect the car further. Two weeks of work were added due to redesigning the PCB. Another two weeks worth of work were added to upgrade the chassis with new motor controllers and implement the backtracking algorithm. The reflected changes are shown in figures 13 and 14.

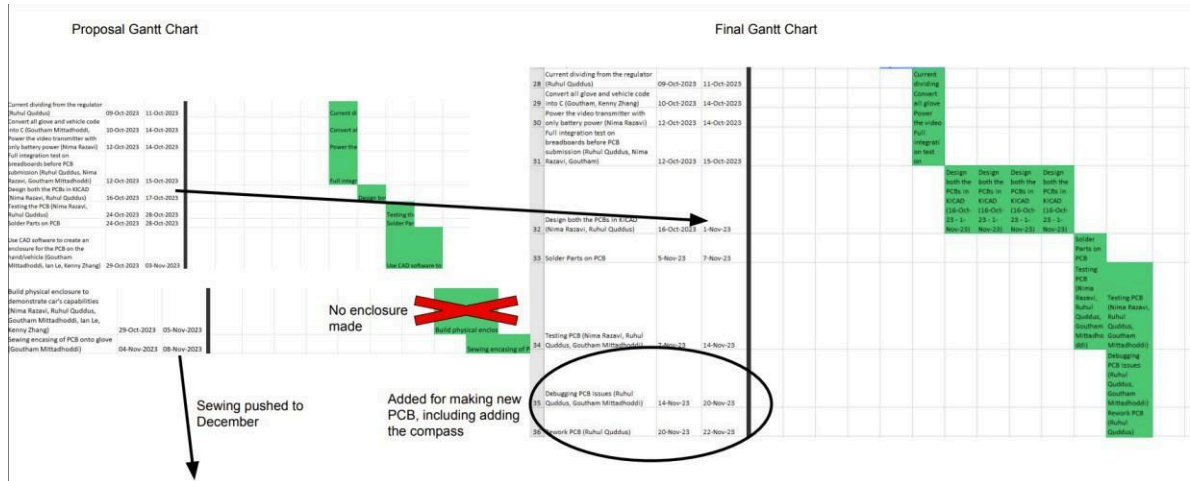

Figure 13: Changes made to Gantt Chart

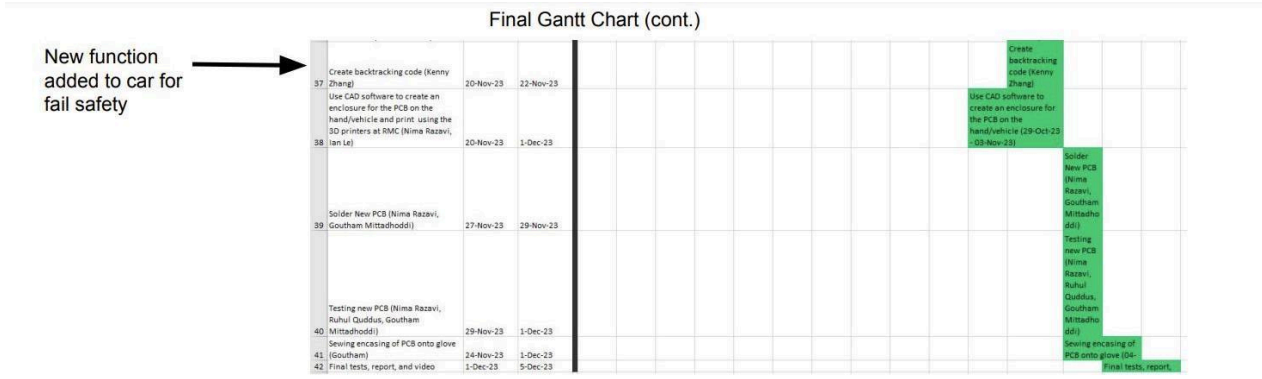

Figure 14: Changes made to Gantt Chart (cont.)

Costs

Total cost for project

A detailed budget breakdown is listed in Appendix 1. The total amount spent on the project came to \$479.47 across both personal and funds from UVA. There was \$179.39 spent from the provided Capstone fund and \$300.08 from our own funding. Some parts were not bought but were used in the final product. The resistors, capacitors, Linear Regulators, and battery connectors were taken from the department’s parts storage and available by permission from department administration. 3D printed components were assembled at the Robertson Media Center and are manufactured for free for students who reserve a printer. PCBs were ordered and manufactured with PCBWay and required a minimum order of 5 PCBs per order. The Budget Breakdown illustrates the categories of cost, the cost for producing 1 unit, and price per unit if 10000 are made. The source of funding for each part was broken down into 3 categories: funds spent using the \$500 Capstone funds (shown in the budget as “UVA”), personal funds (“Personal”), and free parts used with department permission (“Free”). Of the costs, some items were bought and not used in creating the final product. Those items are counted in terms of getting all funds spent but do not increase the cost of production. Additionally, free parts from the department are included in the cost of production and not counted for in terms of the funds spent on the project. Cost estimates for the items used were found on Digikey. The Supplier column shows where a part was purchased from or “UVA” if the part was purchased and used by our group for free. The “Quantity needed for 1 unit” column shows how many of a certain part were used to make 1 unit. Some parts have 0 for this column such as multiple Raspberry Pi Picos that were bought but were destroyed from testing. They contribute to the total cost of the project but not to the cost for producing 1 unit. The quantity ordered column shows how many units of each part was bought.

Cost for 1 unit

The resources that amount to make 1 unit of our product results in a cost of \$207.16. The cost of the materials used with permission from the ECE storage of electrical supplies for small cheap parts like resistors and capacitors were added into the production cost for 1 unit. Ad

Additionally, the free access to the Makerbot Replicator + was utilized and the cost of the Makerbot was not added into our cost estimate. The Makerbot Replicator + is ~\$2000, but 3D printers that can print tough PLA plastic and have a lower print time are available for a higher

cost. The cost for 1 unit includes the cost of the spool of PLA plastic filament.

Cost for 1 unit if mass produced

The resources that amount to making 1 unit using mass production of resources is \$180.94. The lower cost comes from mass production of resistors, capacitors, and most ICs. Since the product requires intricate placement of parts in the car and sewing in the glove, there are not many automated products that could lower the manufacturing cost of producing 1 unit.

Final Results

We met all of our requirements from the proposal. The glove remains connected to the car as long as the batteries stay charged. The connection is fast, meaning that users can control the car accurately and precisely. The bluetooth range is also very good as it goes up to around 120 meters where it starts to lag a little, but could go up to around 150 meters before it disconnects. The haptic feedback system with the ultra sonic and the vibration motor also works as expected with a change in the frequency of vibration depending on the distance the ultrasonic detects. The camera and the receiver work great too. The analog signal range goes up to around 70 meters where some disruption in the signal starts occurring, but could go up to around 100 meters before it completely disconnects. And obviously, the range for the analog signal and the bluetooth is very much dependent on the obstacles between the systems like walls, doors, buildings, etc. Both the glove and the car have been constructed with 3D printed casings to limit the exposure to the electrical components.

Additionally, we added a few extra functionality that are not mentioned in the proposal like changing the car wheels to mecanum wheels along with a bit of vector math in the code for the car to do some fancy driving. We also implemented a power scaling feature to slow down or speed up the car depending on the tilt of the hand. Additionally, we also used a hall effect sensor to change the modes of the car to go between orientation lock and unlock for strafing and spin turns, and finally incorporated a backtracking algorithm for the car when the car disconnects.

Everything works good and as expected except for the backtracking feature, which we are not 100% confident about its functionality. This is mainly because of a few reasons. The car only backtracks the last 15 to 20 seconds after being disconnected, and this is because of the Pico's memory limitations, but this should be good enough for the user to connect back to the car and bring the car by manually driving it from that point, which brings me to my second reason which is that after the initial disconnection, the glove sometimes doesn't connect back to the car if we only reboot the glove. In that case, we have to reboot both the car and the glove to do the connection, but this problem only occurs sometimes.

The third reason is that as we are using cheap motors on the car, the car kind of drifts a little bit. For example, trying to drive forward, the car will sometimes curve a little to the left or right. This is not a big issue when the user is driving the car as they can easily change the direction of the car through their gestures, but this heavily affects the backtracking feature as it is autonomous. We tried using a sensor to use the z-angle data to do heading correction for the drifting, but after a lot of time and effort, we realized that the sensor we were trying to use is not going to work because it detects a change in magnetic field, but as the sensor is moving along with the car and the itself is a magnetic field because of its components, the sensor doesn't detect that much of a change in the magnetic field. We tried manually factoring the

power to correct the drift but that only works when the battery is fully charged because with different power supply, the factor by which it drifts is also different. Overall, we think we met all the requirements and have made a good, functioning, and demo'able project for our Capstone class.

Future Work

Future iterations of this project could implement multiple optimizations to both hardware and software. First, to minimize the size of the PCB on the glove, the components of the Raspberry Pico could be recreated directly on the PCB and surface mounted parts could be utilized. Sockets for ICs and header pins were utilized extensively on the PCB for the ease of testing but this comes at a cost of size. Industry standard sized components can really benefit this project. Additionally, a flexible PCB can bend and conform to the movements of a user and can connect the hall effect sensor without having to pull wires. As the car construction progressed, it was discovered that each motor doesn't receive precisely the same voltage levels, which causes the car to drift slightly. Attempts were made to address this issue in multiple manners including adding a magnetometer and gyroscope on the car to directly calculate the difference between the intended direction and actual direction of the car. Neither of these solutions solved our issue. A software implementation of this would be to add an optical flow sensor to track the visual movement of the car and correct the drifting that way. This approach may be flawed as the car is subject to shaking of the chassis. On the other hand, a hardware solution to this problem could be to use brushless motors. Future students attempting this project should place rigorous testing of the power received by all components instead of only relying on calculations. This project relies on combining multiple discrete systems into one and combining those systems is not a trivial task. Each system has its own voltage and current bounds which provides a unique challenge to those working on the project.

References

- [1] G. Nugent, B. Barker, N. Grandgenett, and G. Welch, "Robotics camps, clubs, and competitions: Results from a US robotics project," *Robotics and Autonomous Systems*, vol. 75, pp. 686–691, 2016. doi:10.1016/j.robot.2015.07.011
- [2] A. Dang, V. Chandorkar, A. Pawar, and D. Pawar, "Hand Motion Controlled Robotic Vehicle with Obstacle Detection," *International Research Journal of Engineering and Technology*, vol. 4, no. 9, pp. 1146–1148, Sep. 2017.
- [3] A. Pabarekar, T. Biju, M. Beck, W. Melba and S. M. Samkutty, "Gesture Controlled Automated Vehicle," 2023 5th Biennial International Conference on Nascent Technologies in Engineering (ICNTE), Navi Mumbai, India, 2023, pp. 1-5, <https://doi.org/10.1109/ICNTE56631.2023.10146681> .
- [4] A. Sultana, S. Fatima, H. Mubeen, R. Begum, K. Sohelrana and A. Jameel, "A Review on Smart IoT based Gesture Controlled Grass Cutting Vehicle," 2020 4th International Conference on Trends in Electronics and Informatics (ICOEI)(48184), Tirunelveli, India, 2020, pp. 440-444, <https://doi.org/10.1109/ICOEI48184.2020.9142981> .
- [5] Raspberry Pi Ltd., "Raspberry Pi Pico W Datasheet: An RP2040-based microcontroller board with wireless," build-version: a6fe703-clean, 2022 [Online], <https://datasheets.raspberrypi.com/picow/pico-w-datasheet.pdf> [Accessed: 12/4/2023].
- [6] "Thonny, Python IDE for beginners," *Thonny.org*, 2018. <https://thonny.org/> (accessed Dec. 05, 2023).
- [7] "MicroPython - Python for microcontrollers," *micropython.org*, 2014. <https://micropython.org/> (accessed Dec. 05, 2023).
- [8] "KiCad EDA," *www.kicad.org*, 2018. <https://www.kicad.org/> (accessed Dec. 05, 2023).
- [9] F15 Committee, "Consumer Safety Specification for Toy Safety," ASTM International. <https://doi.org/10.1520/F0963-17>. Available: <http://www.astm.org/cgi-bin/resolver.cgi?F963-17>, [Accessed: Sep. 17, 2023]
- [10] P. Murray et al., "System and method for controlling swarm of remote unmanned vehicles through human gestures," Jul. 3, 2012
- [11] G. M. Underwood et al., "System and method for applying gesture input to digital content," Sep. 5, 2017
- [12] D. L. Graumann, "Systems, methods, and apparatus for controlling gesture initiation and termination," May 8, 2018
- [13] M. Shilleh, "Connect MPU 6050 To Raspberry Pi Pico W," *Hackster.io*, Jan. 24, 2023. <https://www.hackster.io/shilleh/connect-mpu-6050-to-raspberry-pi-pico-w-7f3345> (accessed Dec. 05, 2023).

- [14] ElecFreaks, "Ultrasonic Ranging Module HC -SR04," 2011. Accessed: Dec. 05, 2023. [Online]. Available: <https://cdn.sparkfun.com/datasheets/Sensors/Proximity/HCSR04.pdf>
- [15] N. C. Out, "DUAL FULL-BRIDGE DRIVER," 2008. Accessed: Dec. 05, 2023. [Online]. Available: https://www.sparkfun.com/datasheets/Robotics/L298_H_Bridge.pdf
- [16] InvenSense Inc., "MPU-6000 and MPU-6050 Product Specification Revision 3.4 MPU- 6000/MPU-6050 Product Specification," Aug. 2013. Accessed: Dec. 05, 2023. [Online]. Available: <https://invensense.tdk.com/wp-content/uploads/2015/02/MPU-6000-Datasheet1.pdf>
- [17] Z. M. Naing, S. Anatolii, H. S. Paing and L. Vinh Thang, "Evaluation of Microelectromechanical System Gyroscope and Accelerometer in the Object Orientation System Using Complementary Filter," 2021 IEEE Conference of Russian Young Researchers in Electrical and Electronic Engineering (ElConRus), St. Petersburg, Moscow, Russia, 2021, pp. 2777-2781, doi: 10.1109/ElConRus51938.2021.9396198.
- [18] "Datasheet HD-EM0802-LW15-R," 2021. Accessed: Dec. 05, 2023. [Online]. Available: <https://www.digikey.com/en/products/detail/pui-audio-inc/HD-EM0802-LW15-R/16522087>
- [19] "LT1121/LT1121-3.3/LT1121-5 - Micropower Low Dropout Regulators with Shutdown." Accessed: Dec. 05, 2023. [Online]. Available: <https://www.analog.com/media/en/technical-documentation/data-sheets/1121fg.pdf>
- [20] "Datasheet - LM217, LM317 - 1.2 V to 37 V Adjustable Voltage Regulators," Dec. 2021. Accessed: Dec. 05, 2023. [Online]. Available: <https://www.st.com/content/ccc/resource/technical/document/datasheet/group1/a0/db/e6/9b/6f/9c/45/7b/CD00000455/files/CD00000455.pdf/jcr:content/translations/en.CD00000455.pdf>
- [21] "DC/DC Converter K78xx-2000R3 Series," Jun. 2023. Accessed: Dec. 05, 2023. [Online]. Available: <https://www.mornsun-power.com/html/pdf/K7805-2000R3.html>
- [22] "Hall Latch -High Sensitivity Features and Benefits Application Examples," 2006. Available: <https://www.sparkfun.com/datasheets/Components/General/Hall-US1881EUA.pdf>

Appendix

	A	B	C	D	E	F	G	H	I	J	K	L
1	Part Name	Supplier	Cost for 1	Cost per unit for 10000	Quantity needed for 1 unit	Quantity Ordered	Source of Funds	Amount Charged	Cost for 1 unit	Cost for 10000 units		
2	PCB Order 1	JLPCB (minimum order size is 5 PCBs)	\$5.43	\$3.20	0	0	5 Personal	\$32.14	\$3.00	\$30.00		
3	PCB Order 2	JLPCB	\$5.51	\$3.20	1	1	5 Personal	\$32.55	\$5.51	\$3.20		
4	AP82205WU-7 (Buck converter)	Digkey	\$0.87	\$0.30	1	1	10 UVA	\$8.70	\$0.87	\$0.30		
5	6078T (Open Finger Work Gloves)	McMaster	\$1.00	\$0.91	0	0	1 UVA	\$1.00	\$0.00	\$0.00		
6	US1881EU-AAA-003-BU (Hall Effect Sen	Digkey	\$1.08	\$0.41	1	1	10 UVA	\$10.80	\$1.08	\$0.41		
7	SC091T (Raspberry Pi)	Digkey	\$5.00	\$5.00	0	0	2 UVA	\$10.00	\$0.00	\$0.00		
8	B06XBZ2R8P (Camera)	Amazon	\$17.99	\$17.99	1	1	1 UVA	\$17.99	\$17.99	\$17.99		
9	B01H36AIGY (AV Receiver)	Amazon	\$10.66	\$10.66	1	1	1 UVA	\$10.66	\$10.66	\$10.66		
10	B08W98BD5L (HDMI Converter)	Amazon	\$9.95	\$9.95	1	1	1 UVA	\$9.95	\$9.95	\$9.95		
11	2725-K7805-2000R3-ND (Buck Converter)	Digkey	\$7.11	\$5.68	1	1	1 UVA	\$7.11	\$7.11	\$5.68		
12	868-HD-EM1003-LW15-R-ND (Haptic Motc	Digkey	\$2.88	\$1.84	1	1	5 UVA	\$14.30	\$2.88	\$1.84		
13	B023VATDP (Rechargeable batteries)	Amazon	\$13.99	\$13.99	1	1	1 UVA	\$13.99	\$13.99	\$13.99		
14	B08N9W4HCOQ (Pico Vln with header)	Amazon	\$14.70	\$14.70	1	1	2 UVA	\$29.40	\$14.70	\$14.70		
15	B0C8R8CFMZ (Set of Mecanum Wheels)	Amazon	\$28.00	\$28.00	1	1	1 UVA	\$28.00	\$28.00	\$28.00		
16	B07BK1QLE8T (Set of 4 motor controllers)	Amazon	\$11.49	\$5.75	1	1	1 UVA	\$11.49	\$11.49	\$5.75		
17	Pico	Amazon	\$14.70	\$14.70	0	0	1 Personal	\$14.70	\$0.00	\$0.00		
18	MPU050	Amazon	\$4.49	\$4.49	1	1	1 Personal	\$4.49	\$4.49	\$4.49		
19	haptic motors	Amazon	\$1.75	\$1.75	0	4	4 Personal	\$6.99	\$0.00	\$0.00		
20	piocs	Amazon	\$14.70	\$14.70	0	2	2 Personal	\$29.40	\$0.00	\$0.00		
21	5v regulators	Amazon	\$0.68	\$0.24	1	20	20 Personal	\$13.60	\$0.68	\$0.24		
22	piocs	Amazon	\$14.70	\$14.70	0	2	2 Personal	\$29.40	\$0.00	\$0.00		
23	piocs	Amazon	\$14.70	\$14.70	0	2	2 Personal	\$29.40	\$0.00	\$0.00		
24	sockets	Amazon	\$0.45	\$0.45	4	2	2 Personal	\$0.90	\$1.80	\$1.80		
25	grommet kit	Amazon	\$9.99	\$9.99	0	1	1 Personal	\$9.99	\$0.00	\$0.00		
26	Copernicus compasses	Amazon	\$7.99	\$7.99	0	1	1 Personal	\$7.99	\$0.00	\$0.00		
27	Hilalpo compass	Amazon	\$6.69	\$6.69	0	1	1 Personal	\$6.69	\$0.00	\$0.00		
28	piocs	Amazon	\$14.70	\$14.70	0	2	2 Personal	\$29.40	\$0.00	\$0.00		
29	piocs	Amazon	\$14.70	\$14.70	0	2	2 Personal	\$29.40	\$0.00	\$0.00		
30	Glove	Walmart	\$12.97	\$12.97	1	1	1 Personal	\$12.97	\$12.97	\$12.97		
31	Hane Thermofoam RS White	Joann's Fabric	\$0.60	\$0.60	1	1	1 Personal	\$0.60	\$0.60	\$0.60		
32	Safety Pins	Joann's Fabric	\$2.99	\$2.99	1	1	1 Personal	\$2.99	\$2.99	\$2.99		
33	Needles	Joann's Fabric	\$4.49	\$4.49	1	1	1 Personal	\$4.49	\$4.49	\$4.49		
34	Thread	Joann's Fabric	\$1.99	\$1.99	1	1	1 Personal	\$1.99	\$1.99	\$1.99		
35	Push button	UVA	\$0.10	\$0.09	2	0	Free	\$0.00	\$0.20	\$0.11		
36	555 Timer	UVA	\$0.02	\$0.37	2	0	Free	\$0.00	\$1.84	\$0.74		
37	LT1121 (Lin Regulator)	UVA	\$4.95	\$2.39	2	0	Free	\$0.00	\$9.90	\$4.78		
38	1 microfarad Capacitor	UVA	\$0.04	\$0.20	4	0	Free	\$0.00	\$3.76	\$1.20		
39	1 microfarad Capacitor	UVA	\$0.32	\$0.07	3	0	Free	\$0.00	\$0.96	\$0.21		
40	47 microfarad capacitor	UVA	\$0.42	\$0.10	2	0	Free	\$0.00	\$0.84	\$0.20		
41	100 kOhm Resistor	UVA	\$0.38	\$0.05	2	0	Free	\$0.00	\$0.76	\$0.10		
42	10 kOhm Resistor	UVA	\$0.10	\$0.01	2	0	Free	\$0.00	\$0.20	\$0.01		
43	1 kOhm Resistor	UVA	\$0.38	\$0.05	2	0	Free	\$0.00	\$0.72	\$0.10		
44	5.6 kOhms Resistor	UVA	\$0.21	\$0.03	1	0	Free	\$0.00	\$0.21	\$0.03		
45	2N2904 (BJT)	UVA	\$0.26	\$0.04	1	0	Free	\$0.00	\$0.26	\$0.04		
46	1N4001 (Diode)	UVA	\$0.20	\$0.03	1	0	Free	\$0.00	\$0.20	\$0.03		
47	TLV272 (Op-Amp)	UVA	\$0.02	\$0.37	1	0	Free	\$0.00	\$0.02	\$0.37		
48	White PLA Filament	UVA	\$24.99	\$24.99	1	0	Free	\$0.00	\$24.99	\$24.99		
49												
50												
51								\$479.47	\$207.16	\$180.94	Sums	
52											Personal Funds spent	
53								\$300.08				
54			Sum w/o extra	\$347.17								

Appendix 1: Budget Outline