

ASNE PEP2024 Unmanned Design Competition Final Technical Report

**Autonomous Maritime Vehicle Team
Connor Lyons, William Renken, Nathan Vu, Ryan Wood, Jona Zvazenewako**

Department of Mechanical and Aerospace Engineering, University of Virginia School of
Engineering and Applied Science, Charlottesville, Virginia, 22904

Date of Submission: May 10, 2024

Faculty Advisor: Dr. Tomonari Furukawa
Department of Mechanical and Aerospace Engineering, University of Virginia School of
Engineering and Applied Science, Charlottesville, Virginia, 22904

1. Introduction.....	6
2. Background.....	8
2.1 Essential Knowledge.....	8
2.2 Research.....	10
3. Design Process.....	13
3.1 Customer Needs.....	13
3.2 Target Specifications.....	14
4. Conceptual Design.....	16
4.1 Conceptual Generation.....	16
4.2 Conceptual Analysis.....	17
4.3 Conceptual Modeling and Simulation.....	19
5. Hull Design and Structures.....	23
5.1 Hull Design.....	23
5.2 Hull Scanning and Modeling.....	24
5.3 Battery Storage Unit and Frame.....	25
5.4 Battery Mounts.....	28
6. Electric Propulsion System.....	29
6.1 Power Source.....	29
6.2 Current Routing.....	33
6.3 Electric Motors.....	37
6.4 Electronic Speed Controller.....	41
6.5 Powertrain.....	43
6.6 Propeller System.....	46
7. Controls and Navigation.....	51
7.1 Pixhawk Controller.....	51
7.2 Control System.....	53
8. Thermal Management System.....	54
8.1 Cooling System.....	54
8.2 Cooling Mount.....	55
9. Final Design.....	58
9.1 Competition Design.....	58
9.2 Experimental Validation and Testing.....	62
9.3 Post Competition Design.....	64

10. Conclusions and Future Work	70
References.....	72
Appendix A: LiPo Battery Safety	75
Appendix B: Operations Manual	82

Team Members



Connor Lyons
Powertrain



William Renken
Frame and Powertrain



Nathan Vu
Electric Propulsion System



Ryan Wood
Cooling and Documentation



Jona Zvazenewako
Controls

Faculty Advisor – Tomonari Furukawa

Figure Index

- Figure 1: Main Blocks of the System
- Figure 2: Functional Decomposition of the AMV
- Figure 3: Morphological Analysis of the AMV
- Figure 4: The “Raw” 3D Scan with the BSU Fitted in SOLIDWORKS
- Figure 5: BSU, Shown Above from Water Jetted Aluminum, Inside the Hull
- Figure 6: Battery Mount Assembly
- Figure 7: Battery Chemistry Comparison Graph
- Figure 8: Thermal Imaging of LiPo Batteries under extreme loading
- Figure 9: Stuffing Box Assembly
- Figure 10: Flexible Aluminum Coupling
- Figure 11: Example Propeller Performance Chart in Air
- Figure 12: Servo rudder mount
- Figure 13: Complete Controls System involving Pixhawk Flight Controller & Mission Planner
- Figure 14: Mapping of Controls on Logitech Gamepad
- Figure 15: 3D Printed Cooling Mount Isometric View
- Figure 16: Cooling Mount Front View
- Figure 17: Cooling Loop Between the Motor and ESC
- Figure 18: Competition System Diagram of Hardware and Electronic Components
- Figure 19: Outside View of Hull
- Figure 20: View of the Drivetrain and Navigation Systems
- Figure 21: View of the Batteries and Fuses in Position
- Figure 22: Boat Testing in Water
- Figure 23: Telemetry Data from the Competition
- Figure 24: Post Competition System Diagram of Hardware and Electronic Components
- Figure 25: Rudder Installed on the Hull
- Figure 26: Flexible Shafts Installed and Connected to Motors

Table Index

- Table 1: Target Specifications of the AMV
- Table 2: Morphological Analysis of the AMV
- Table 3: AMV Concept Screening
- Table 4: AMV Concept Scoring
- Table 5: AMV Competition Design Hardware Specifications
- Table 6: AMV Competition Design Hardware Specifications
- Table 7: Comparison of LiPo versus LiFePO4 Batteries
- Table 8: Neumotor Catalogue for Various Versions of the 2215 Motor
- Table 9: Competition Hardware Specifications

Table 10: Post Competition Hardware Specifications

1. Introduction

With the world increasing its focus on the prevention of pollution, including the production and subsequent release of greenhouse gases into the atmosphere, creating a means of powering devices without the use of coal or natural gas has become paramount. Recently, many industries have shifted from the use of fuel to using batteries for power. Electric, battery-powered cars have made an impact in the 21st century, as companies like Tesla continue to push the bounds of innovation in the field. Now, ships and other maritime vehicles are looking to do the same, creating a more sustainable method of propulsion through the water, one that does not have a harmful effect on the environment over the years (Naqvi et al., 2022).

The Promoting Electric Propulsion (PEP) competition is an annual competition sponsored by the American Society for Naval Engineers (ASNE) and funded by the Office of Naval Research (ONR) (American Society of Naval Engineers, 2024). The goal of the PEP competition is to initiate the development of electric propulsion in boats. Many vessels currently use gasoline to propel themselves through the water. Since other industries, like the automotive industry, are furthering their development of electric vehicles, it makes sense that the boating industry will follow a similar trajectory. In PEP, teams of students from colleges across the U.S. compete in manned and unmanned divisions to be the fastest team to complete a five-mile course using only electric propulsion. There are many rules of the competition which are outlined below (ASNE, 2024):

1. Entry is open to any vessel, manned or unmanned, operating with an electric propulsion system.
2. Vessels shall have appropriate fit and finish to appear seaworthy; no “Frankenstein” vessels.

3. All vessels must comply with USCG safety regulations.
4. Gasoline engines, recharging via an onboard generator, sails, and manual propulsion are prohibited during the competition. Solar power and other renewable systems may be onboard to recharge.
5. Competitors will not have a charging station available to them on site.
6. ASNE will provide a radio and air horn for race communications.
7. There must be a high-voltage disconnect through which all high-voltage current must travel. If the disconnect is manually moved to off, then all high-voltage electrical systems should cease.
8. There should be a contactor kill switch easily accessible to the operator. This regulation could be addressed through a 12V (or similarly low-volt) switch that would kill the contactor and act as a high-voltage disconnect.
9. The container holding the battery must be able to secure the battery within the boat in the event it capsizes.
10. For high-voltage systems, there must be a fuse through which all battery current must travel. The fuse should be rated to protect the high-voltage system wiring in the craft.
11. Boats must include a location on the front of the craft where a 1/2-inch tow rope can be mounted to safely tow the craft back to shore.

The competition's rules mainly govern the safety of spectators and participants. They do not mention much about what type of vessel should be used, aside from the fact that electric motors must be used. Because of the limited rules governing the design of hulls, there is not a design that has been converged upon by the teams in the competition. Thus, in previous years, teams created vastly different designs that had varying strengths and weaknesses.

As for the objectives of the project, there are tasks to complete for the specific customer the boat is built for, but there is also the goal to complete the course and win the competition. These objectives include creating an autonomous boat of approximately 8 feet in length, where the

boat must be powered by electric propulsion, be unmanned, be able to complete the entire five-mile course with remote operation, must look seaworthy, and contain features that allow it to be safely recovered from the water. These objectives are straightforward, and as it is the University of Virginia's first year in competition, setting a solid baseline for future attempts is a reasonable goal for the year.

To complete the previously mentioned objectives, the following outline was observed. First, the hull of the boat was decided upon and created. After selecting the hull, everything else within the boat could move forward in development. This included frame design, motor, battery, and gearbox selection, cooling systems, and navigation and controls systems. All components needed to be selected to give the boat the highest chance of success in the spring competition.

The remainder of the report will introduce the methods used to complete the design of the autonomous maritime vehicle (AMV), which include efforts of past teams, customer needs, target specifications, concept generation, and concept selection. Once those methods are analyzed, the final design will be presented, current progress will be discussed, and conclusions will be addressed that can lead to future work.

2. Background

2.1 Essential Knowledge

The Autonomous Maritime Vehicle began in the fall of 2022. The team was tasked with creating an aquaculture robot capable of autonomously maneuvering and cleaning offshore aquaculture pens. The previous project was split between three universities: the University of

Virginia (UVA), Stevens Institute of Technology (SIT), and Virginia Tech (VT). Through splitting the project into smaller subprojects, each university's team could accomplish their task with the hope of combining the three schools' work to create a functional aquaculture robot.

The team at UVA was tasked with creating an autonomous surface vehicle (ASV) tethered to an underwater autonomous remotely operated vehicle (AROV) (Tilney-Volk et al., 2023). The surface vehicle consisted of two kayak plastic floats connected with aluminum extrusions. The team used BlueRobotics T200 propellers with differential steering to propel and turn the vessel. As for the software and electronics, the boat used BlueOS, a commercial controls program from BlueRobotics, which contains QGroundControl and ArduSub navigational software. The electronics for the surface vehicle were housed in a watertight box atop the aluminum extrusions. This housing contained a navigation controller using a Raspberry Pi module and a computer. Finally, the surface vehicle has a closed loop water cooling system to keep components from malfunctioning due to excessive heat. For the AROV, the team at UVA simply bought the BlueROV2, an off-the-shelf high-performance ROV. It contains a six-thruster vectored configuration and open-source electronics and software (BlueRobotics, 2023). However, the team did not do much to improve the capabilities of the AROV, so it will not be explained in detail any further.

The team at SIT researched underwater and surface sensing capabilities, with the hope that higher levels of autonomy would be able to be reached when it was connected to the combination of the ASV and AROV (Sutin et al., 2013). These underwater and surface sensing developments would allow the vessels to navigate the pens with little human interaction. Additionally, SIT

developed robotic manipulators to aid in dead fish removal, as well as net-sensing techniques so that the ROV would not get caught while traversing the aquaculture farm.

At VT, the main goal was to develop an energy harvesting system. Through the rocking nature of the waves, energy can be obtained to recharge the surface vehicle (Bushey, 2016). The Wave Energy Capture System (WECS) was then created to obtain a solution. The linear rise and fall of the waves are converted to rotational motion through a series of pulleys. Then, the rotational motion is converted to electrical energy with induction, and the electrical energy is used to recharge the vessel.

That said, while the aquaculture robot and other similar vessels are an advanced vessel, it was not created to compete in a racing competition. Therefore, a new design will be created that incorporates speed, endurance, stability, and reliability. The following sections will illustrate the proposed design and explain the process used to develop the final design.

2.2 Research

In 2010, Freire et al. published a paper describing aspects of modeling a boat's electric propulsion system (Freire et al., 2010). The system studied in the research is provided in Figure 1 below. The system shows a basic propulsion system, where a battery is connected to a power converter, providing current to a motor which rotates a propeller on the hull.

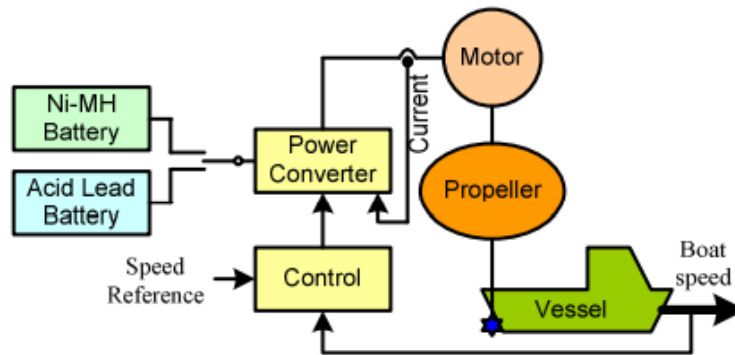

Fig. 1. Main blocks of the system.

With gasoline engines having an energy density of over 50 times that of lithium-ion batteries, a question must be asked: is electric power the long-term solution that provides effective, but also environmentally friendly, power to motors. Over the past 15 years, battery efficiency has doubled in the switch from lead acid to lithium-ion batteries (Naqvi et al., 2022). More advanced mechatronic systems, including sensors, controllers, and actuators allow for more control over the system's output. Autonomous systems rely heavily on mechatronics, taking in real-world data and using that data to influence decision-making on certain criteria.

In the previous years of the PEP competition, there have been several approaches to creating an electrically powered, unmanned vessel capable of completing a 5-mile course. Two of the most common approaches are vessels made for speed and vessels made for endurance.

A prominent example of a boat designed for speed is the Florida Atlantic University (FAU) vessel, which competed in the Promoting Electric Propulsion (PEP) competition in 2023. This boat averaged 8 miles per hour over 4.5 miles (Greater Fort Lauderdale Alliance, 2023). Its speed was relatively strong compared to the competition, but the lack of endurance prevented it from finishing the race. This boat was a twin hull, plastic boat with aluminum extrusions connecting the two hulls to hold the vessel together. The upside of creating a boat meant for speed is that it will almost

always be light and have a great power-to-weight ratio, as well as being easily maneuverable. While it is difficult to tell exactly why the boat failed, the most likely causes are due to either structural failure or electrical or battery failure. All the previously mentioned possible failure points are examples of the cons of boats designed with speed in mind. While they can travel at high rates of speed, the design principles that allow this can cause other problems due to a variety of factors. For example, there is typically less hull material used for stability or waterproofing and less battery capacity for weight reduction.

The other school of thought for this task is the boat created with endurance in mind. An example of such a boat is the Navy Large Unmanned Surface Vessel (LUSV), which is described to be high-endurance and capable of sustaining weeks-long deployments and trans-oceanic transits (Harper, 2023). The LUSV is extremely large and well out of the cost range of a competition such as PEP, but it can be scaled down and analyzed like an endurance boat in the competition. The pros of these types of boats are that they almost always are solidly constructed and have a very small chance of being capsized by rough conditions on the water. They also have extensive battery life for long-lasting travel. However, even though the battery life might be significantly improved in comparison to the vessel built for speed, that does not always mean the boat will travel further - the longer battery life still might run out before the total distance is exceeded.

3. Design Process

3.1 Customer Needs

The first step in any design process is to identify customers and their needs. Customers for the Autonomous Maritime Vehicle (AMV) project include the UVA VICTOR Lab, as well as the competition sponsors, the American Society of Naval Engineers and the Office of Naval Research. From the VICTOR Lab, identified customer needs were that the boat should be less than 8 feet long, be teleoperated for five miles, and have efficient navigation. For the ASNE and ONR, the PEP competition has an outline of set rules and requirements that vessels must adhere to. The needs from the VICTOR Lab were combined with the competition rules to create a set of interpreted needs, as listed below:

- All vessels must comply with USCG safety regulations.
- The vehicle must be propelled using electric propulsion with onboard batteries. Solar may be used to recharge.
- The vessel should be unmanned.
- The boat should be able to operate remotely while completing a 5-mile course.
- Hull should be cohesive and well put together. Seams and joints should not fall apart.
- ½-inch tow rope required for safe retrieval.
- The batteries must stay on the boat if the boat capsizes, and in general.

The interpreted needs were combined into five different categories, each representing a different value to be held when designing the vessel. The final ranking of the needs, weighing multiple criteria, was:

1. Safety Considerations & Mechanisms

2. Electric Propulsion
3. Autonomy and Remote Control
4. Speed/Operational Capabilities
5. Survivability

3.2 Target Specifications

After identifying and ranking customer needs, target specifications, or ideal performance values, for the boat to achieve were identified. Target specifications identified were speed, weight, endurance, and others. In the chart below, each target specification is listed with its relative importance, as well as ideal and marginal quantitative values to achieve in performance. To win the PEP competition, ideal target values should be achieved. Marginal target values are benchmarks that should be aimed for based on previous performance of competitors in the unmanned division.

Target Specification	Maximize/Minimize Importance?	Ideal Target Value	Marginal Target Value
Speed	Maximize	Greater than 10 mph	Greater than 4 mph
Weight	Minimize	Less than 90 lbs	Less than 150 lbs
Turning Radius	Minimize	Less than 5 ft	Less than 20 ft
Endurance	Maximize	Greater than 5 miles	Greater than 3 miles
Communication Distance	Maximize	Greater than a mile	Greater than a half mile
Safety	Maximize	Less than 1 injury	Less than 1 injury
Stability	Maximize	90° of rotational stability	50° of rotational stability
Environmental Impact	Minimize	0 lb CO2	Less than 100 lb CO2
Cost	Minimize	Less than \$7000	Less than \$9000

Table I: Target Specifications for the AMV

A Quality Function Development (QFD) chart quantifies the technical importance of each specification and prioritizes its development relative to the others. After filling out the QFD, the order of technical importance was calculated as the following:

1. Endurance (13.3%)
2. Speed (13.2%)
3. Weight (12.9%)
4. Cost (12.8%)
5. Safety (12.1%)
6. Stability (9.9%)
7. Environmental Impact (9.1%)
8. Turning Radius (8.8%)
9. Communication Distance (7.9%)

The ranking shows that, above all else, endurance should be prioritized, as completing the entire five-mile course is the project's goal. Speed is another priority, as the fastest time to complete the course is the winner.

4. Conceptual Design

4.1 Conceptual Generation

Once the most important target specifications are decided upon, possible concepts for the AMV can be created and debated. To create a concept that will meet the requirements of the competition, inputs and outputs from the overall system must be understood. Inputs to the AMV include RC signals and electric power. Outputs can be positive, like thrust and steering, or negative, like vibration and heat. The selected concept must maximize the output from thrust and steering, while minimizing the hindrance caused by vibration and heat. The input and output diagram of the AMV is shown below:

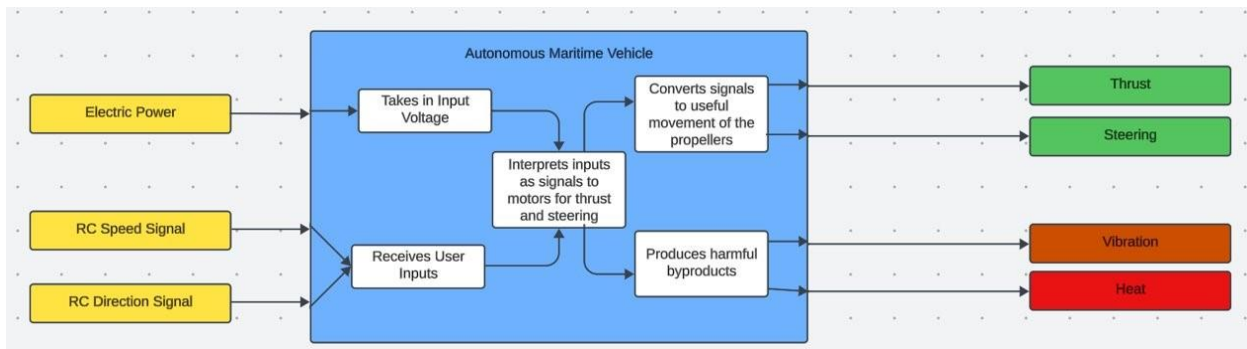

Figure 2: Functional Decomposition for the AMV

Using the inputs and outputs, a design can be proposed that, in theory, will maximize the positive outputs and minimize the negatives. The conceptual AMV is similar to the aquaculture robot, but with a few hydrodynamic components that will allow for increased speed and stability. Comparing just the proposed design with the aquaculture robot would be trivial, so including successful PEP designs and the Navy LUSV in the comparison yields the greatest variation across the vessels. Table 2 distinguishes the four designs with their respective characteristics from each

other. The AMV conceptual design (blue) was compared with the aquaculture robot (red), FAU’s 2023 PEP unmanned vessel (orange), and the U.S. Navy LUSV (green). The generated AMV concept is an unmanned vessel with a single V-hull made of carbon fiber. It houses a mini-computer and is guided through the use of ArduSub. The vessel is to be operated remotely through radio signals. The electric power is supplied through batteries, which allows for twin engine steering and an integrated water-cooling system.

Sub-Functions	Solutions						
Hull Type	Single V-Hull	Twin Hull	Flat Bottom	Hydrofoil	Hover	Submersible	
Hull Make	Carbon Fiber	Plastic	Wood	Constructed	Composites		
Computer Processing	Laptop	Mini Computer	Arduino	Raspberry Pi	Other Microcontroller	Propeller Chip	
Programming	ROS1	ROS2	ArduSub	Custom Program	Other Commercial Program	None	
Remote Control Method	Wi-Fi connect	Radio Control	Fully Autonomous	Guided Semi-autonomy	Radio Control via ArduPilot		
Electric Power Supply	Battery	Solar	Capacitor				
Propulsion	Electric Motor	Electric Pump	Paddle Wheel	Aero-propeller	Oar Mechanism		
Steering	Twin Engine	Conventional Rudder	Intentional Drag	Control Surfaces	Motor PWM		
Thermal Cooling	Water Cooling	Passive Cooling	Air Cooling	Air to Water Cooling	?		

Table 2: Morphological Analysis of the AMV

4.2 Conceptual Analysis

To finalize a plan for the design to continue with, each of the four concepts are screened and scored using metrics based on some of the target specifications outlined at the beginning of the design process. Screening involves assigning a positive, neutral, or negative rank in a variety of categories, from the computer utilized and programming to the propulsion and thermal cooling of the vessel. Because all four designs were assigned to be continued, as shown in Table 3, concept scoring was necessary to make a final decision.

Potential Solution → Selection Criteria ↓	Aquaculture Robot	Our Potential Solution	FAU PEP 2023 Vessel	Navy Surface Drone
Hull Type	0	+	0	+
Hull Make	0	+	+	+
Computer/Processing	0	0	0	+
Programming	+	+	0	0
Remote Control Method	-	+	+	0
Electric Power Supply	0	0	0	+
Propulsion	+	+	+	+
Steering	+	+	+	0
Thermal Cooling	0	0	0	0
Sum +'s	3	6	4	5
Sum 0's	5	3	5	4
Sum -'s	1	0	0	0
Net Score	2	6	4	5
Rank	4	1	3	2
Continue?	Yes	Yes	Yes	Yes

Table 3: AMV Concept Screening

To score the designs, each of the nine listed criteria was given a weight proportional to their importance to the project's overall success. Each of the designs was scored from 1 to 5 in the nine criteria and ranked relative to the others. After tallying up the net scores for each design, it was shown that the proposed AMV design had the highest score, revealing that it would be the best one to move forward with. Table 4 shows the final ranking of the four designs, where the best is the proposed AMV solution, followed by the Navy Surface Drone, FAU vessel, and the aquaculture robot.

Solution →		Aquaculture Robot		Our Potential Solution		FAU PEP 2023 Vessel		Navy Surface Drone	
# Selection Criteria ↓	Weight	Rating	Weight	Rating	Weight	Rating	Weight	Rating	Weight
1 Hull Type	15%	3	0.45	5	0.75	3	0.45	4	0.6
2 Hull Make	11%	2	0.22	5	0.55	4	0.44	5	0.55
3 Computer/Processing	10%	3	0.3	3	0.3	4	0.4	5	0.5
4 Programming	15%	4	0.6	4	0.6	2	0.3	3	0.45
5 Remote Control Method	11%	1	0.11	4	0.44	4	0.44	5	0.55
6 Electric Power Supply	11%	3	0.33	3	0.33	3	0.33	4	0.44
7 Propulsion	11%	5	0.55	5	0.55	5	0.55	5	0.55
8 Steering	11%	4	0.44	4	0.44	4	0.44	3	0.33
9 Thermal Cooling	5%	4	0.2	4	0.2	3	0.15	3	0.15
	100%		3.2		4.16		3.5		4.12
		RANK	4		1		3		2

Table 4: AMV Concept Scoring

4.3 Conceptual Modeling and Simulation

Estimating the performance of the boat hull is crucial to success in the competition. A variety of tools were initially investigated to help refine the conceptual design parameters to understand how performance was affected by design decisions, such as Javaprop, Ansys Fluent, and Solidworks. SolidWorks provides a basic hydrodynamic drag and streamline visualization tool for this purpose. To prepare the test model, a smooth CAD model is created that roughly follows the outline of a 3D scanned hull. This smooth model is created instead of a CAD solid directly from the 3D scan because the CAD solid contains too many edges, drastically increasing solution time due to irregular geometries at the surface/fluid boundary. As a result, the smooth model varies slightly compared to the real-life hull, but the minor differences between the two are unlikely to make a significant difference in the simulation. The simulation estimates the drag performance of the hull in the water at various water depths and speeds using multiphase air and water flow. The simulation also allows observation of the predicted wake to visualize expected fluid effects from the rotating propellers at the back of the boat.

Using the free surface solution solver, a two fluid solution with water below a certain point and air filling up the rest of the bounding box is created. The size of the computation box is based on a reference point at the back of the hull. The dimensions of this box are 1.5 meters to either side of the hull, 4 meters in front, and 4 meters in behind. The analysis in Figure 3 shows the 10-mph case relative to the surface of the water. Since the flow uses a relatively dense fluid traveling at a slow speed, a computational mesh size with extra mesh refinement around the edges of the boat

produces viable results. Simulations assist in identifying the wake size behind the boat, which allows for expanded knowledge of the expected flow passing through the propellers. Simulating flow, combined with future in-water testing, yields more accurate performance expectations and informed decision-making in design, such as propeller efficiency and ideal propeller shaft lengths.

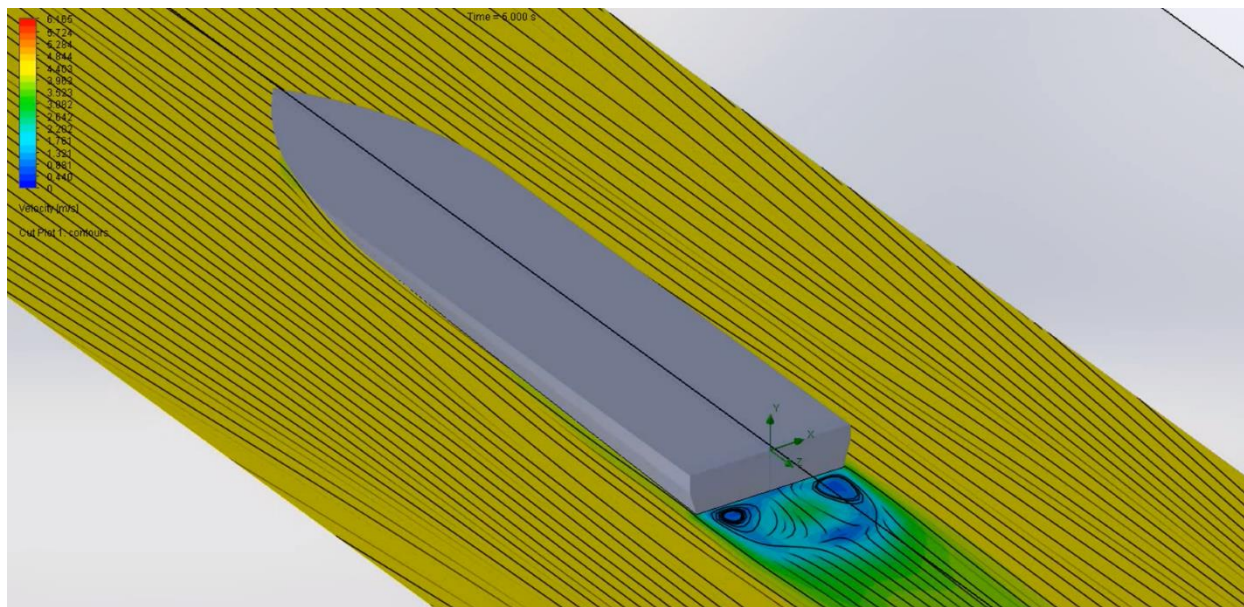

Figure 3: Streamline visualization on a velocity profile along the water line

Another trade study necessary for understanding the system is one that assesses the maximum electrical power that can be used with a combination of components. Table 1 shows the permutations in speed of the boat and its effect on the maximum race time and maximum allowable current to draw over the race. The table integrates limitations from the components' specifications and those set by the vessel's goal speed. Boxes highlighted in red describe unacceptable performance levels according to the target specifications, while sections highlighted in yellow

must be surpassed to succeed in the PEP competition. Green sections of the table show ideal minimum performance levels of the vessel to strive for in competition.

			Percentage of Capacity Use		100
			Battery pack capacity [Ah]:		20
TABLE 1: Maximum Electric Power			Length of the race [mi]		5
Speed [mph]	Duration [hr]	Duration [min]	Max A for 1P [A]	Max A for 2P [A]	Max A for 3P [A]
1	5.000	300.0	4	8	12
2	2.500	150.0	8	16	24
3	1.667	100.0	12	24	36
4	1.250	75.0	16	32	48
5	1.000	60.0	20	40	60
6	0.833	50.0	24	48	72
7	0.714	42.9	28	56	84
8	0.625	37.5	32	64	96
9	0.556	33.3	36	72	108
10	0.500	30.0	40	80	120
11	0.455	27.3	44	88	132
12	0.417	25.0	48	96	144
13	0.385	23.1	52	104	156
14	0.357	21.4	56	112	168
15	0.333	20.0	60	120	180
16	0.313	18.8	64	128	192
17	0.294	17.6	68	136	204
18	0.278	16.7	72	144	216
19	0.263	15.8	76	152	228
20	0.250	15.0	80	160	240
21	0.238	14.3	84	168	252
22	0.227	13.6	88	176	264
23	0.217	13.0	92	184	276
24	0.208	12.5	96	192	288
25	0.200	12.0	100	200	300
26	0.192	11.5	104	208	312
27	0.185	11.1	108	216	324
28	0.179	10.7	112	224	336
29	0.172	10.3	116	232	348
30	0.167	10.0	120	240	360

To interpret this table, take the 10-mph average speed case. At this speed, the expected time to complete the race is 30 minutes. If a 1 parallel (1P) configuration of batteries is used, an average of 40 amps can be drawn to each motor. 2 and 3 parallel configurations of batteries can draw averages of 80 and 120 amps per motor respectively. Also, if the race is not completed in 30 minutes in a 1P configuration, the battery capacity will be drained prior to the completion of the five-mile course. Averaging greater than 40 amps per motor will also necessitate completion of the course prior to 30 minutes, or else the batteries will be drained of power. The study and associated table define boundaries as to what constitutes a successful race in a variety of average speeds and configurations of batteries. A successful race averaging 10-mph must be completed in less than 30 minutes or averaging less than 40 amps in a 1P setup.

Table 1 can be used in conjunction with testing on the water to determine not only whether a certain combination of propulsion components, control cruise throttle, and battery capacity could complete a race, but also inform whether the maximum power is being drawn from the system. Taking an example from propeller planes, one way to absorb more engine power to convert into greater thrust is to increase the amount of air being moved by the propellers through increasing their diameter. Increasing propeller diameter increases the load on the motor as a byproduct. If a certain speed can be identified experimentally where only a fraction of the maximum current is drawn from the system, then the propulsion system can be upscaled to consume more power. Upscaling the system can involve increasing the propeller diameter to move more water per second, increasing overall thrust. However, it is important to understand the efficiency limitations of the propulsion system and physical limitations of the placement of components within the hull.

Increasing the size of the propellers too much can cause them to interfere with each other and cause harmful effects on the system.

5. Hull Design and Structures

5.1 Hull Design

The hull's importance is the highest in the design process – as a result, it was selected first due to its independence in design from the propulsion and control systems. Selecting the hull allows for other design work that relies on its geometry to continue. After evaluating previous works of other teams, such as the aquaculture robot and PEP 2023 teams, an 84” displacement hull from Bonzi Sports was selected, with its large interior volume allowing for the storage of the large array of batteries required to meet the power goal. Creation of a hull from scratch can increase freedom in design and allow for many specialty parameters, like center of gravity, to be tuned. However, the reliability issues and long construction times, coupled with the fact that previous PEP teams commonly fail due to custom hull failure informed the decision against manufacturing a custom hull in-house.

The hull selected is a V-Shaped hull, which performs as a large displacement hull due to the size, shape, and speeds expected. The hull is constructed from a carbon fiber composite. This material choice was dictated by several design requirements, but chiefly the hull must have a high strength to weight ratio. Strength is paramount because of the repetitive stresses of incoming waves on the outside of the hull coupled with the weight of the batteries and internal systems pushing down internally. Additionally, deformation of the hull could cause seals to fail as they lose the surface area they are adhered to. Lightness is also a strong motivator for this material choice – the

batteries and motors are heavy, which causes a higher draw where the hull sinks further into the water. If the hull were made of a heavier material such as aluminum, this effect would be accentuated.

Carbon fiber also has high implications for thermal performance – the composite has a high thermal conductivity, which allows for the batteries to be passively cooled through the hull itself and the hull to dissipate heat through the surrounding water.

For aesthetic reasons, the color of the hull is black. While the hull certainly has an imposing presence at the lab and during initial testing, this choice continues to have significant consequences on thermal design as the black outer paint causes the hull to absorb heat (reducing the thermal benefits of the material choice). The implications of this will be expounded later in the thermal design section. Future teams should be wary of this effect and should ideally choose a color that absorbs less heat, such as white.

5.2 Hull Scanning and Modeling

Computer Aided Design (CAD) is a critical tool for designing custom parts. Because no file exists for the hull design from Bonzi Sports, the manufacturer, this step is necessary for the design to prevent a “guess and check” approach for something as critical as the frame. Without the hull scan, guessing and checking could lead to design delays and waste of material if parts do not fit within the hull correctly (not to mention the fact that guessing and checking is not a sustainable engineering practice). The initial step in the CAD modeling process is the most challenging: 3D scanning and the subsequent post-processing of the hull file. Creaform’s GoScan portable 3D scanner creates a point cloud of the hull which can be converted into the industry standard STL format. With this STL file, CAD models can be developed using precise measurements of the hull.

In addition, refined hydrodynamic analysis can be performed to estimate its performance metrics in the water.

5.3 Battery Storage Unit and Frame

The Battery Storage Unit (BSU) is a structural frame responsible for holding the batteries in the hull during the race and providing additional rigidity to the hull walls. The BSU has several design constraints that need to be satisfied. It must:

- a. Fit into the hull well such that the hull geometry of the hull can use the BSU as structural support,
- b. Be strong enough to withstand impacts on the outer hull shell from waves approaching the vessel at 10 mph or faster,
- c. Have sufficient space for battery storage,
- d. Provide solutions for easy cable management, and
- e. Provide some form of passive cooling to the ambient air of the vessel.

After the hull was scanned, the design of the frame can be created. The scanned hull and supporting structure along with the BSU are shown below in Figure 4:



Figure 4: The “Raw” 3D Scan with the BSU Fitted in SOLIDWORKS

The design challenges outlined above are addressed using the principles of common “rib” frame designs found on many recreational and military vessels using traditional internal combustion engines. A central spine is mounted along the middle contour of the hull, and ribs, which lie perpendicular to the spine, are laid in increments throughout the body. The central spine provides support for frontal impacts due to high speeds, while the ribs prevent the hull from cracking due to the rocking and turning movements by distributing loads along the entire hull surface. For the material of the structure, 1/8” thick 6061 aluminum was selected due to its light weight and strong material properties that make it ideal for performance vehicles, which is why it is a favorite in aerospace while also being relatively affordable and easy to work with. In addition, the aluminum can conduct heat away from potential hotspots to help with distributing heat away. The aluminum can be water jetted to cut 2D designs used in the project to create flat components. To secure the hull's structure, aluminum brackets were used that had a large flat surface set to be

flush with the bottom of the hull. The brackets each used a series of set screws to hold the ribs in place and are glued to the hull using JB-Weld. High-strength, high-heat JB-Weld was selected for its strength of over 5000 psi, which should be more than enough strength for our designed system.

The choice to use JB-Weld has twofold reasoning: it is extremely strong when used correctly and is simple to apply. The high-strength, high-heat resin that was chosen is designed to be used on internal combustion engine blocks – this application justified its use in this case, where the heat and application of force are orders of magnitude less than rated.

The final production version of the BSU without the brackets can be seen in Figure 5, which shows the ribs of the BSU running along the central spine. Battery mounts, described in the next subsection, fit in between the ribs to provide maximum security for the batteries.



Figure 5: BSU, Shown Above from Water Jetted Aluminum, Inside the Hull

5.4 Battery Mounts

To support the batteries chosen for the competition, Turnigy 20000 mAh 6S 12C batteries, mounts are utilized so that the batteries can be secured in the hull while the boat undergoes rocking and turning throughout testing and competing. Each battery can weigh as much as 5.75 lb, and initially at least 8-12 batteries are needed to fit in the hull. Although the BSU provides protection from the batteries sliding, it is best to secure them further to ensure critical systems inside the hull, especially electrical wiring, are not broken or detached throughout the race. A 3D printed battery mount allows for the batteries to sit comfortably and not be in danger of breaking themselves, but also security through a Velcro strap to make sure they do not shift from rib to rib. The CAD model, with batteries included, is shown below in Figure 6. 3D printing the mounts allows for rapid prototyping as well as cost savings since the structural properties of the 3D prints are sufficient, since not much load bearing is expected. The mounts are secured to the hull using JB-weld along the bottom surfaces, allowing strong bonds that prevent the mount from coming loose during a race.

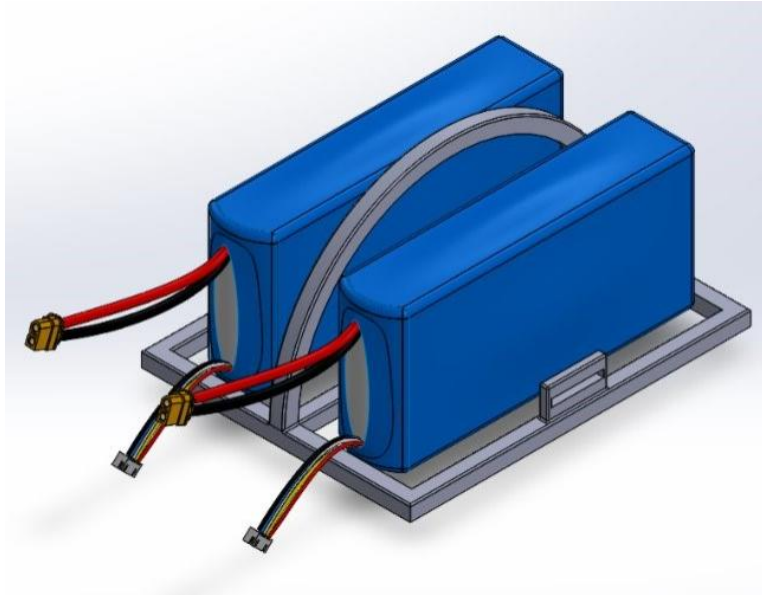

Figure 6: Battery Mount Assembly

6. Electric Propulsion System

6.1 Power Source

For the power source, multiple different sources were initially developed. Inspiration was taken from already existing vehicles, such as the running electric cars on the road, electric boats or electric aircraft. Exotic power sources such as capacitor banks and electrical fuel cell batteries were ruled out as unfeasible for our application scale (Pastra et al., 2022). The prevailing energy source that is used in our final design was battery storage, which is used in most electric vehicles due to their ability to store power and provide high voltages for sustained durations. However, it is important to understand the features that comprise battery technology as it directly influences the performance metrics of the AMV (Antcliff and Capristan, 2017).

Battery chemistry is one of the main defining parameters for determining the capabilities of the electrical power that can be carried in the vehicle. Two key parameters for choosing the type of electrical battery used in a weight sensitive application, such as a speed boat or an aircraft, are the specific energy and energy density (Antcliff and Capristan, 2017). Specific energy is a measure of how much energy is stored per unit of weight, which is critical for evaluating how much weight is added to carry a certain amount of energy needed to propel the increased weight of the vehicle forward. For example, the specific energy of Jet A fuel, a kerosene-based hydrocarbon, is 24 times higher than that of a lithium battery with 500 Wh/kg that can be expected for entry into service by 2035 for the aircraft industry (Antcliff and Capristan, 2017). This means replacing a kilogram of fuel means replacing it with 24 kilograms of battery assuming no change in propulsion architecture efficiency. Different battery chemistries will have vastly different potentials for how much energy can be stored per kilogram of battery. Energy density, on the other hand, is a measurement of volume, or how much energy can be stored given a certain volume of free available space. Some forms of energy storage, such as hydrogen fuel cells, are quite high in specific energy compared to lithium batteries, but in space limited applications, this can be a challenge to have enough volume to fit the cells onto a vehicle and have enough supporting structure to operate the vehicle safely (Pastra et al., 2022).

These two parameters from electrical aircraft design take effect with the naval application of electrical propulsion because the battery chemistry will determine how much weight and volume the batteries will take up to go the full duration of the five-mile competition course. Popular battery chemistries are shown in Figure 7 and projected in a current state-of-the-art chart.

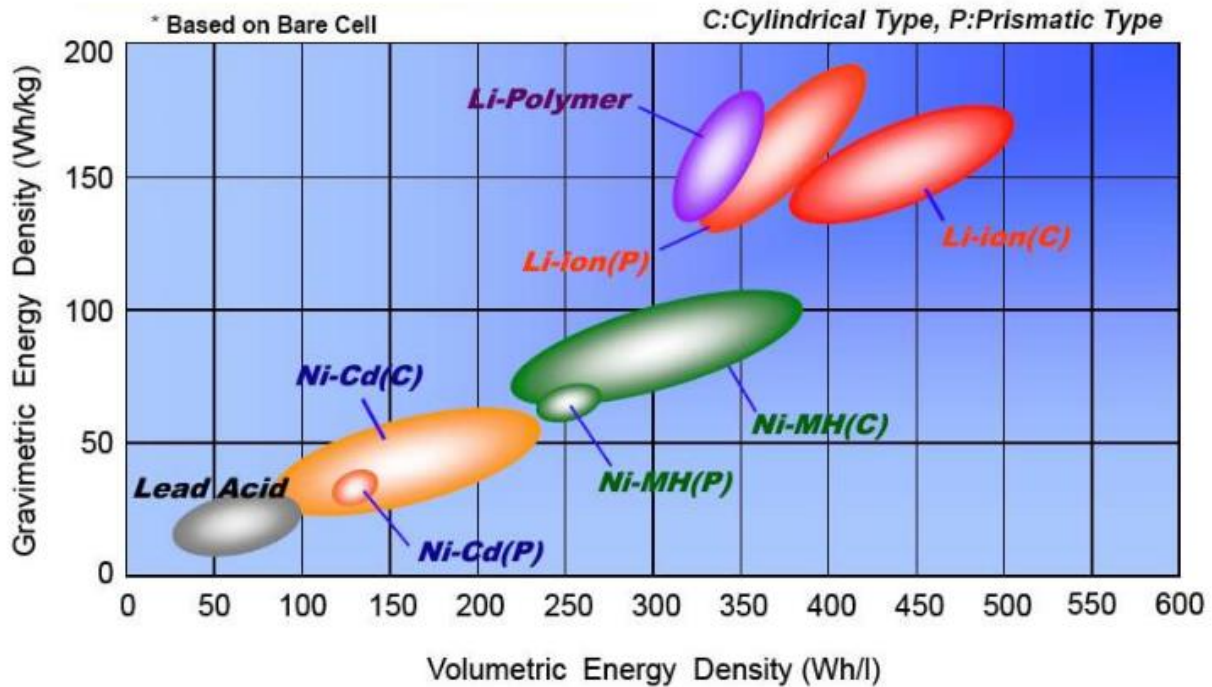

Figure 7: Battery Chemistry Comparison Graph (NASA Ames)

Interpreting this graph from NASA Ames shows how lithium is currently leading the state-of-the-art in terms of energy storage capabilities, which led to its selection. However, even within the category of lithium batteries, there are significant differences in their performance. Table 7 illustrates an example comparison between a LiFePO4 battery provided by Dakota Lithium and a LiPo battery provided by Turnigy (Dakota Lithium and Turnigy, 2024).

Chemistry	LiFePO4	LiPo (6S)	LiPo Pack
Battery Count	1	1	10
Nominal Voltage	48 V	22.2 V	44.4 V
Capacity	96 Ah	20 Ah	100 Ah
Weight	35 kg	2.63 kg	26.3 kg
Dimensions	520x267x220mm	203x93x70mm	203x93x70mm * 10

Volume	0.0305 m ³	0.00132 m ³	0.0132 m ³
Cost	\$2700	\$201	\$2010
Discharge/Charge Cycles	4000+	300-500	300-500
Lifespan (Estimated)	11 Years	2-4Years	2-4 Years

Table 7: Comparison of LiPo versus LiFePO4 Batteries

From the table, a clear difference in capability can be seen between the LiFePO4 battery and the LiPo battery in terms of weight and volume. This is why choosing an efficient battery in power metrics has synergistic effects on overall vehicle performance especially when it comes to the electrification of all kinds of vehicles. However, even though the LiPo has better performance, it does have its disadvantages, such lower number of charge cycles. Due to the lower number of charge cycles, LiPo batteries will lose their maximum performance capabilities in terms of maximum charge much sooner than other chemistries and start to see negative effects sooner. This often means that to maintain similar performance, LiPo batteries will have to be replaced more often. LiPo batteries are notorious for requiring special attention and knowledge of handling to prevent destabilization of the chemistry within the cells, where improper or negligent techniques can lead to puffy batteries that can pose a serious fire and detonation hazard to the environment where they are stored in. However, our system analysis determined that this battery chemistry was required to meet the performance expectations at the competition.

One additional specification chosen for our battery power storage was a limit of 48V. This limit is derived from conversations with the event participants and organizers, who have been moving the competition towards a 48V limit for the unmanned division. As part of the customer needs, the system needs to have longevity between years of the team, so this additional restriction needs to be considered. With the 48V limit, this means that the maximum LiPo cell count in series

would be a 12S or 12-Series configuration, which would provide 44.4V at nominal voltage. After comparing several vendors for LiPo batteries, the aforementioned Turnigy provides the best battery capabilities per dollar cost with their 6S 20 Ah batteries. By running two batteries in series, a 12S configuration could be achieved to reach the 44.4V for the system.

In our conceptual design, significant focus is required for designing around a twin motor setup for differential thrust. This means that two separate banks of batteries are needed to power each side. Adding capacity to the system means that four batteries would need to be added to balance out both systems. The final configuration uses eight batteries in a 2-Series and 2-Parallel configuration, which is known as a 2S2P configuration. This configuration for a twin power setup provides the boat with 40 Ah of energy capacity each for a total of 80 Ah. This capacity is quite high for typical RC boats, which usually rely on only one or two batteries. The difference, however, is that most RC boats are only designed to run for short periods of time and short distances, which is not suitable for the application of an endurance range of over five miles for the competition.

6.2 Current Routing

One of the critical considerations of an electrical system is the amount of current that flows through it. Current is one of the main issues that limits many electrical components, as it determines how big components must be to safely handle appropriate levels of current and dissipate the heat that can be expected to be generated. The dangers of overloading current can be seen in Figure 8, which shows thermal imaging of a test setup done on a set of LiPo batteries (Bell, 2024).

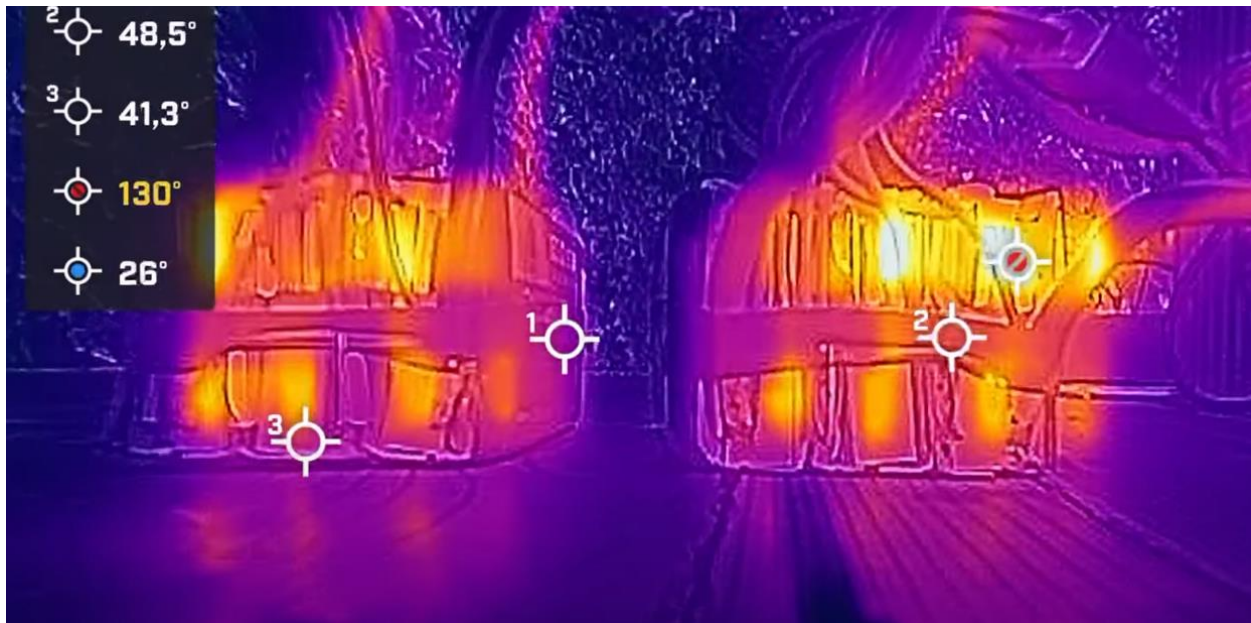

Figure 8: Thermal Imaging of LiPo Batteries under extreme loading (Bell, 2024)

Figure 8 shows one of the primary issues when determining the current that the AMV should be running at is the battery temperatures, specifically the leads for the battery connectors. Turnigy uses XT90 connectors on their batteries, which can sustain 90 amps of current, but can usually handle upwards of 100 amps before the heat causes the connections to desolder. This desoldering mechanism acts as a safety mechanism to avoid drawing too much current from the battery over long periods of time. However, one of the issues with being limited to 100 amps is that the maximum power that the proposed system will be able to provide with 50V at 100 amps is 5000W, or 6.7 hp. For several of the motors, the team was looking at running nearly 300 amps for maximum power. While a new set of connectors could be soldered to the batteries that would allow for more current to be drawn from the batteries, there is a significant risk of overheating the batteries by drawing more current than what is recommended by the manufacturer. Choosing to

go beyond the manufacturer's recommendations for extended periods of time or under extreme loading can cause thermal runaway to occur, such as what happened to the LiPo batteries in Figure 8. While the test setup in Figure 8 is meant for designing world-record setting drone speeds, where the battery is usually irreparably damaged beyond the first few discharges, it shows how going beyond the expected current draw can cause the batteries to reach temperatures exceeding 48 °C, or 118 °F. In the spot where the wires physically melt, the temperature recorded in Figure 8 are 130 °C, or 266 °F. One of the key target specifications of the AMV is safety, and having wires melting during operation is not conducive to safe design.

To avoid this issue, electricity can be routed in parallel, which would allow for more wires that each carry a fraction of the original load. In the initial concept, the motors the AMV expected to run could handle up to 300A of current. This meant that with the XT90 connectors on the batteries, three parallel banks of batteries would need to be used. While this would increase capacity to 60 Ah, allowing the boat to run at safer currents and have much longer endurance ranges, it would add a significant amount of volume and weight to the hull. In the initial concept design for developing parameters, batteries comprised of one of the largest sources of weight in the boat. This would force the design to be able to accommodate batteries deeper into the hull, which would be ergonomically much more difficult. The additional weight posed a potential risk to the bending of the V-shaped bottom of the hull, which would be sustaining 12 batteries at over 70 pounds of weight from the batteries alone. This is why the decision was made to lower the maximum current of the system from 300A to 200A.

To properly route the batteries in parallel, a set of 4-stud bus bars is used that can handle up to 250A each. Bus bars are a popular electrical choice for routing high amounts of currents in

residential buildings and other high-power applications. The other advantage of bus bars is the scalability and adaptability to make changes to the system once the bus bars have been installed. With four studs, the bus bars can handle up to four different connections. For this application, up to three sets of batteries could be connected coming in, with the last stud being dedicated for power going out. This solution allows for future changes to the electric power system, such as changing the batteries to have slightly less capacity each but in a configuration with 2S3P, allowing for 300A of current to be drawn for the system. Smaller capacity would also mean that the weight addition of using more batteries is diminished since each battery would be slightly lighter.

With the system current set at 200A, the rest of the electrical routing components can be sized. For safety reasons, a master disconnect switch and emergency stop must be included so the boat can be powered down quickly in a catastrophic event. To satisfy this requirement, a circuit breaker rated for a maximum of 200A before tripping is used on the boat. The goal of including this circuit breaker would be that it limits the maximum current flowing through each side to a maximum of 200 amps before automatically tripping, saving the components from a potential overloading of the current. This circuit breaker also acts as a convenient power switch and emergency stop in case of a catastrophic failure. The other advantage of a circuit breaker is that the mechanical nature allows for the circuit breaker to be reused. Since the expected current and voltages of the system are extremely uncommon and only used for specialty purposes or industrial applications, most fuses of this size are quite large and can be expensive to replace. By using circuit breakers, the issue of implementing large fuses can be avoided. However, using circuit breakers does come with some disadvantages, namely that the mechanical nature of the circuit breakers

causes the response time to be potentially much slower than fuse, allowing a longer time for the dangerous levels of current to pass through the system.

For the other components, 8-gauge wire was used for the heavy current connections with large copper lugs that would safely handle the current between connections. Since each battery wire would handle only a portion of the current, a thinner 10-gauge wire was sufficient, which helped with wiring of the battery banks since many wires are needed for the series and parallel connections.

6.3 Electric Motors

In the initial conceptual design, one of the key targets was completing the course as fast as possible. To accomplish this goal, a high amount of power would be required. Due to the \$7000 expected budget limits however, this limited the selection of motors in power capability. In addition, the motors are extremely important to the system's success, so using a reliable motor is critical. For the electric propulsion system, the Castle 2028 800 Kv 12S 300A motor is used. While the power output is very high, this motor is also used because it has a proven record during speed RC car competitions with extensive testing footage available online. If running the motor at its maximum specifications of 12S with 50V at 300A, it gives each motor a power rating of 20.11 horsepower. While our electric propulsion system runs at 200A, this would still give our motors a respectable power output of 13.4 hp each.

One of the key considerations when selecting a motor is the RPM of the motor. Specifically in motor ratings, this value is quantified by the Kv rating of the motor. The Kv rating is a measurement of how much RPM the motor can expect to output per volt applied to the motor.

Since the motor is rated for 800 Kv, the no load, free spinning RPM of the motor at 50 volts would be around 40,000 RPM. In addition, the Castle company lists a maximum RPM of up to 45,000, which could suggest that the Kv rating is a little lower than its actual rating, or that it can handle additional voltages as a safety margin. A motor's Kv can also be used as a tool to compare the differences between motors, such as in Table 8, which is a snippet of a motor catalogue from Neumotors, which provides hundreds of motor sizes for both RC hobbyists and industrial applications.

Motor	KV	Rm Ohms	Io @ 10v	Torque Constant		Max Volts (max rpm/Kv)	Max Amps (max watts/volts)
				mNm/A	inOz/A		
2215/24/3Y/207	207	0.108	0.7	46.2	6.55	145	35
2215/24/2.75Y/225	225	0.091	0.7	42.5	6.02	133	38
2215/24/2.5Y/248	248	0.075	0.8	38.6	5.46	121	41
2215/24/2.25Y/276	276	0.061	0.9	34.7	4.91	109	46
2215/24/2Y/310	310	0.048	1.0	30.9	4.37	97	52
2215/24/1.75Y/354	354	0.037	1.1	27.0	3.83	85	59
2215/24/1.5Y/413	413	0.027	1.3	23.2	3.28	73	69
2215/24/1.25Y/496	496	0.019	1.6	19.3	2.73	60	83
2215/24/1Y/575	575	0.009	3.2	16.6	2.36	52	96

Table 8: Neumotor Catalogue for Various Versions of the 2215 Motor.

Figure 9 illustrates how the Kv value can be used to develop motor sizing comparisons to determine the best type of motor for an application. From Figure 9, as the Kv value increases, the torque that the motor can provide decreases. The physical construction of the motor directly affects Kv, with various factors being the number of windings per coil, the type of winding, the number of coils, among several other factors. This also means that when selecting a motor, lower Kv values mean that the motor is able to generate more torque per amp compared to the same

category of motor that has a different configuration. For the AMV, one of the main concerns during the initial conceptual design process is that the loading on the propellers would cause the system to draw an increased number of amps. Since lower amps means less current flowing through the system, from this relationship, a lower Kv value motor should be selected. This is why between the two options for the Castle 2028 motor, one at 800 Kv and the other at 1100 Kv, the lower Kv value motor is used. This means that the 800 Kv motor will have greater torque per amp while also having a lower RPM. Going back to the importance of RPM, the RPM is one of the main factors that determines the efficiency of the propellers. From aircraft design, one of the main limitations in propeller aircraft is the propellers rotating so fast that the tip of the propeller exceeds the speed of sound, causing shockwaves to develop that reduce the effectiveness of the propulsion system (Carichner and Nicolai, 2013). A similar effect happens with underwater propellers called cavitation, when the propellers spin so fast that the static pressure, as the blade of the propeller moves the surrounding water, falls below the vapor pressure of the water, causing bubbles to form. These bubbles can have serious negative consequences on the efficiency of the propellers as it creates miniature underwater shocks that reduce the available energy contained in the moving fluid that has been imparted by the propeller's rotation. Cavitation worsens with higher RPM of a motor. The worst-case scenario means that going with a slower RPM would be better because a higher RPM may result in a loss of efficiency in thrust.

While the motor's performance is central to the success of the boat's performance, consideration must be taken of the potential vibrations. Vibrations can be devastating on the structural integrity of the mounting and the connection to the hull. This is why the design of the mounting interface for the motor is important. Two designs were proposed, one using 3D printed

parts and one using the metal ribs used for the structural frame. The 3D printed design could be iterated with the capability to use complex geometries while also being able to be fabricated easily. However, one of the main disadvantages of using 3D printed components is that the load bearing capability of the extruded plastic is much lower than aluminum. In addition, 3D printed components cannot survive extremely high temperatures, so localized hot spots where the print would contact the motor might be subjected to localized melting. The Castle 2028 800 Kv motor has a maximum rated temperature of 180°F, and overheating the motor risks melting the protective coatings of the wires within the motor. These reasons are why an aluminum rib was utilized as the mounting interface for the motor based on the ribs used for the structural frame. The aluminum would be able to handle the motor's high loads and conduct heat away from it, acting as a fin to improve the passive cooling capability of the motor. This specialized mounting rib was adapted to have a series of screw holes for the motor. During testing, the motor remained securely in place.

Motor selection and mounting is extremely critical, but one aspect of the conceptual design that has not been fully explained yet is the twin motor design. The twin motor design serves two purposes. The first reason is that with twin motors, differential thrust becomes possible when one motor spins faster than the other to turn using thrust vectoring or differential steering. This eliminates the need to have a rudder, which reduces the total drag of the hull, leading to better performance. The second reason for the twin engine design is that it is simply a method to add power to the boat while avoiding the 48V limit that was part of the additional design constraints that the competition is moving forward with. This allows the design to have a better power-to-weight ratio, which will allow for better speed and acceleration, improving overall performance for the competition.

6.4 Electronic Speed Controller

One important distinction between the motors that are being used in the boat and motors commonly seen in small kits that are typically powered just using a battery is that a special piece of electronic equipment must be used to control the power being sent to the motor leads. This is because for these brushless DC motors, they have 3 leads instead of the normal positive and negative leads seen in many electrical components that require power. Due to how the coils are wound within this high-performance motor, it requires a modified relay setup with six switches to route the power through the correct set of coils at the right time. This component is named the Electronic Speed Controller, or ESC. This piece of equipment is often bundled together with its own simple microcontroller that is responsible for both receiving a pulse-width modulation (PWM) signal from the controller to convert those signals into the properly timed set of switches that activate sequentially. These components are often very complex, and larger ESCs capable of handling a lot of power can cost several hundreds of dollars depending on the amount of features provided.

The first part in choosing an appropriate ESC is the power rating. ESCs need to be capable of handling the power that they are sending to the motors, which means that the ESC needs to be sized for the same amount of power coming into the motor. One of the issues with this is that the power in the system with 50V at 300A is extremely high compared to most other systems in the RC hobby space and is approaching specialized industrial scale equipment. One of the reasons why the 300A sizing was used instead of a lower amount is that the ESC should be sized to handle currents greater than the system that it is being used in. The ESC needs to be capable of handling

the heat generated by the power being sent through the system as well as potentially very short bursts of current. Failing to size the ESC high enough could mean that the ESC could blow prematurely below the expected amp rating, because the ESC suffered a short burst of high current that is often seen during changes in load, like when powering on the motor from an idle state. The AMV's high system amperage demands mean that potential options for ESCs are limited, and there are not many vendors capable of providing an ESC capable of handling up to 300A. The final selection is a 300A electronic speed controller from a company called ZTW rated for up to 14S voltages, which are more than capable of handling the expected electrical loads, which offered the necessary capabilities for the AMV at an affordable price.

However, while power is one of the main concerns for choosing an appropriate ESC, there is an additional factor to consider. Many of these ESCs contain a small microcontroller that interprets the PWM signal from the controller to determine the appropriate timing for the relay switches within the ESC. This timing is extremely important, because if the wrong timings are sent to the motor, the stator of the motor can become desynchronized from the pulses of the ESC. These pulses fail to turn the motor's shaft as they are countered by the stopping torque of an incorrectly timed pulse. This timing is calculated based on an assumption of the motor's configuration, which is mostly similar for a large array of DC brushless motors. This is not the case for the motor in the AMV, which has a different number of magnetic poles (four) instead of the normal six. This has two effects on the ESC design. If the current that the ESC can send is high enough, then the six poles that the ESC is sending power for into the four-pole motor is not a problem, because once the motor starts to spin, it naturally exceeds the incorrect timing of the ESC once the revolution rate matches the frequency of the pulses. However, if the ESC is not capable of sending enough

current to override this “stopping torque” caused by the incorrect timing of pulses, then the motor’s shaft remains relatively stuck in place while current keeps being sent to the motor, causing a stall. If there was a way to cause the motor to spin up to a minimum threshold frequency determined by incorrect pulse timing, then the ESC could successfully control the motor above this minimum threshold of rotation. However, once the motor needs to stop, the motor would not be able to self-start again unless it receives additional help to spin the shaft back up to the minimum threshold rotation rate. The other effect that incorrectly timed ESC pulses can cause is a reduction in the motor’s performance. Since the timing is not optimized, this means that the motor will draw additional current to turn the same amount of torque as an ESC that has the correctly timed pulses.

6.5 Powertrain

Some of the most critical design comes from developing the powertrain that links the motor to the propeller. For the initial conceptual design for the powertrain system, large vessels were researched, with the team noting how they managed to rotate the propeller shaft while keeping water out. To keep the water out of the hull, while keeping the shaft free to rotate, a seal must be created that also acts like a bearing to support the shaft. To convert electrical power into thrust in the water, a solid shaft system is commonly used on large ships, so that forms the basis of the original conceptual design due to its high durability. To seal the shaft, a stuffing box brass tube fits around the outer surface of the shaft, with twin brass bushings acting as support bearings for the shaft. The brass stuffing box tube has enough clearance between the tube and the shaft that motor oil can be poured into the gap, lubricating the shaft and bushings while also preventing water from entering the boat. Early on in development, running a dry test with the shafts caused the

shafts to warp due to the friction heat after the test was finished, so the lubricant is essential for the function of the stuffing box. The stuffing box assembly is pictured in Figure 9 (Harbor Models, 2024).

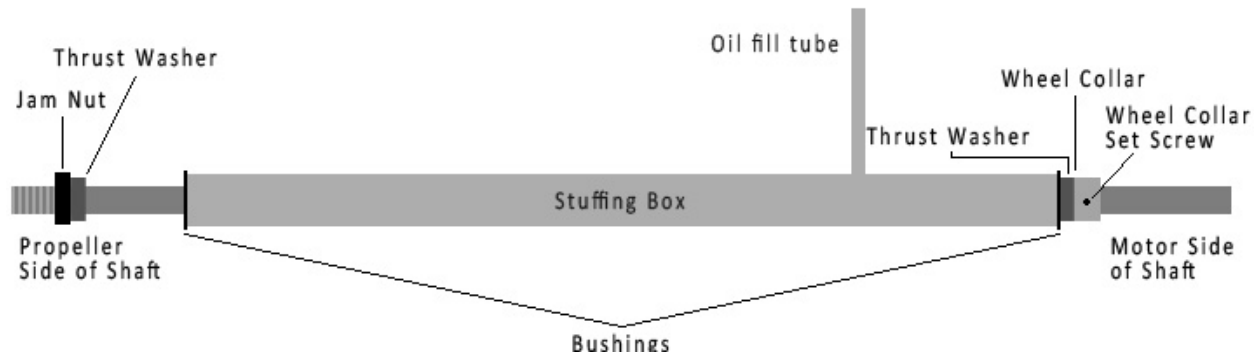

Figure 9: Stuffing Box Assembly

To hold the stuffing box exterior in place while also creating a watertight seal, the stuffing box fits through a hole in the hull. To seal and hold the stuffing box in place, sealant was initially used, however after testing it was discovered that this would not be sufficient since the sealant could not hold the stuffing still as the motor tried to rotate the propeller shaft with extreme power. An improved construction is now installed on the boat, which uses several washers with large amounts of JB-Weld applied between the washers, stacking them along the shaft so that an extremely sturdy and watertight seal can be made over the 24 hours it takes for the JB-Weld to cure. While the construction initially did not hold well without duct tape since the JB-Weld had not cured, after the 24 hours with the duct tape holding the stuffing box in place, it is extremely sturdy and capable of sustaining for greater loads than what is expected out during water racing. It is critical to make sure that the stuffing box was inserted at the correct angle before the JB-Weld cured, which is explained in the next paragraph.

One of the issues with the solid shaft system is that in using a V-Hull with a twin engine setup, there was difficulty developing a mounting solution for the propeller shaft since the shafts need to be at an angle so that the propellers could be submerged into the water. To ameliorate this issue, the motor mounting rib uses a special set of cut aluminum brackets to help angle the motors downwards by a few degrees. In addition, the stuffing box assembly is also mounted at a further downward angle. Because the motor shaft was no longer completely aligned with the propeller shaft, a flexible coupling was required to connect the motor to the propeller shaft.

To solve the issue of the misaligned shafts, a flexible shaft coupler is used, allowing the motors and shafts to be installed at a slight angle, causing the propeller shaft to sit closer to the waterline and the propellers to be fully submerged. Figure 10 shows the helical beam coupling that uses the compliant bending of the thin aluminum to achieve its flexibility (McMaster-Carr, 2024). However, one of the issues with this coupling is that it is only rated for 10,000 RPM, which is far faster than the RPM of the motors during no-load testing. This means that to operate the coupling safely, a reduction in the RPM is necessary while the motor is running at full voltage.



Figure 10: Flexible Aluminum Coupling

To achieve the RPM reduction, a gearbox is needed to decrease the amount of torque required by the motor at steady state top speed, which would therefore improve our driving range due to the decreased current. A planetary gearbox with a 9:1 gear reduction is used because it

provides sufficient reduction to get below 10,000 RPM. The gearbox selected was the VEX planetary, which has the advantage of having adjustable stages so that different ratios of gear reductions can be tested, while also being a robust gearbox in many robotics competitions. The final free spinning RPM of the motor under no load is around 4500 RPM. To lubricate the gearbox, grease is applied so that the smaller sun gears within the gearbox are able to rotate freely along with the planetary gear.

In the final design, the powertrain uses flexible cable shafts instead of solid shafts. This is because in the testing on the water, the planetary gearbox is not sufficient for the conditions. On competition day, it was hot, the boat had been absorbing radiation, and the grease that had been reapplied had worn off due to the angular pressure causing the gearbox to be unbalanced. This external pressure causes the gears to have unbalanced pressure pressing against each other, which causes the grease to wear thin quickly since the grease is being pushed out at the contact point between the gear and the pin that holds the gear. These causes directly led to the failure of the gearbox during competition. With the introduction of flexible shafts, the flexible coupling is replaced by the ability of the flexible shaft to curve, removing the need to use the gearbox.

6.6 Propeller System

For the propeller system side of the electrical propulsion system design, the appropriate size of the shaft and the propeller must be selected. From research, the most commonly available propellers for RC boats are around ¼" or smaller diameter shafts. This constraint, as well as a desire to use the largest possible shaft to reduce the effects of possible loading, backs the reasoning behind the selection of the ¼" shaft and propellers. As mentioned briefly before, due to the hull's

geometry, twin engine design, and waterline, the shaft is slightly angled downwards so that the propeller could be submerged into the water.

The aluminum propellers are attached onto a component called a drive dog, which is a set-screw collar that has protrusions that the propeller's keyways will fit over, allowing for securing and rotating of the propellers. The drive dogs are designed in tandem with the propeller so that the propellers are removable, allowing for various types of propellers to be tested using the same propeller shaft without much hassle. In addition, due to the angle of the shafts, the propellers can sit below the waterline, moving the maximum amount of water possible.

In terms of propeller design, only a limited amount of testing could be done due to time constraints. One consideration that was made was debating whether to employ hydrodynamic analysis to refine the propeller's performance and potentially develop a propeller that would be optimized for the expected boat's performance and the RPM of the motor for maximum efficiency and thrust. To utilize this hydrodynamic analysis, 3D printing of the propellers would be needed, which as mentioned before, could lead to significantly higher loading of the propellers. This could potentially cause the propellers to snap or would require the propellers to be designed with such a thickness that they would not see significant improvements. In addition, usage of commercial off-the-shelf components for CNC aluminum racing propellers is more reliable and quicker, with the option to test from a selection of various proven racing propellers instead of having to iterate through designs. For the propellers that can be utilized, there are normal 5-pitch propellers that have a diameter of 4" or 6". In addition, there is a selection of smaller diameter 72mm or less RC racing propellers that are meant to be surface piercing. These RC racing propellers are designed to operate near the surface of the water and extreme motor RPM to create super cavitation. While

cavitation is usually bad for performance, as it causes a loss in efficiency due to localized bubble shocks in the flow, super cavitation under very specific circumstances will shroud the racing surface piercing propellers in a very thin layer of air. This effect causes the object to experience much less drag, but the criterion to achieve this relies on fast rotation of the propellers, very sharp edges, and sufficient positioning of the propellers such that this effect can be utilized (Jiang et al. 2018).

In terms of optimizing propeller design, there are a few things to consider. The diameter and pitch of the propeller both contribute to the amount of water that can be moved by the propeller at any given time. It is beneficial for the propeller to move more water, generated from higher amounts of torque from the motor. However, there is an equilibrium point at which the propellers cannot move more water due to the geometric constraints and limitations of the RPM of the motor. If the motor is utilizing its maximum power, it is in the optimal condition of the propeller for that combination of motor torque, RPM, vehicle speed, and propeller geometry. However, iteration is often required to achieve this, as it can be difficult to tune these parameters in tandem due to the deeply coupled physics that govern fluid iterations (Antcliff and Capristan, 2017). In the case where the propeller requires too much torque, and the motor is unable to provide enough torque, then the motor would suffer a current issue where it needs to pull more current than it is capable of. This leads to issues like thermal runaway within the motor coils, where the protective coatings of the wire in the coils starts to melt away, increasing the temperatures as the wires fuse together, causing further increases in temperature until the motor fails. The other case is when the propeller is underpowered, where the motor is spinning the propeller at its maximum RPM, but the motor still has additional power to spare since the propeller is only consuming a constant level of torque at

the maximum motor RPM. From previous discussions, the torque of a motor is a function of the amps it draws, so in this case the motor is not drawing the full number of amps. This can be beneficial since from the previous simulation and trade studies, consuming less power than expected means that the race can be completed with surplus battery remaining. However, unused battery is wasted potential in terms of speed, meaning the propeller should be upscaled in diameter or aggressiveness of the pitch to increase the amount of water that it is moving, consequently resulting in more torque being required at equilibrium, and more power being drawn. Caution must be exercised, because iterating so that the propeller consumes too much power means overloading the motor and causing a failure like mentioned before. To develop the optimal propeller, balancing the propeller's characteristics with the available power of the motor is critical. Achieving all of this within the optimal RPM range of the propeller in the expected flow conditions at the boat's cruising speed can be a difficult optimization task. Figure 11 illustrates one such performance chart for an aerodynamic propeller, and the various possible variables that would need to be iterated to achieve near-optimal results (Antcliff and Capristan, 2017).

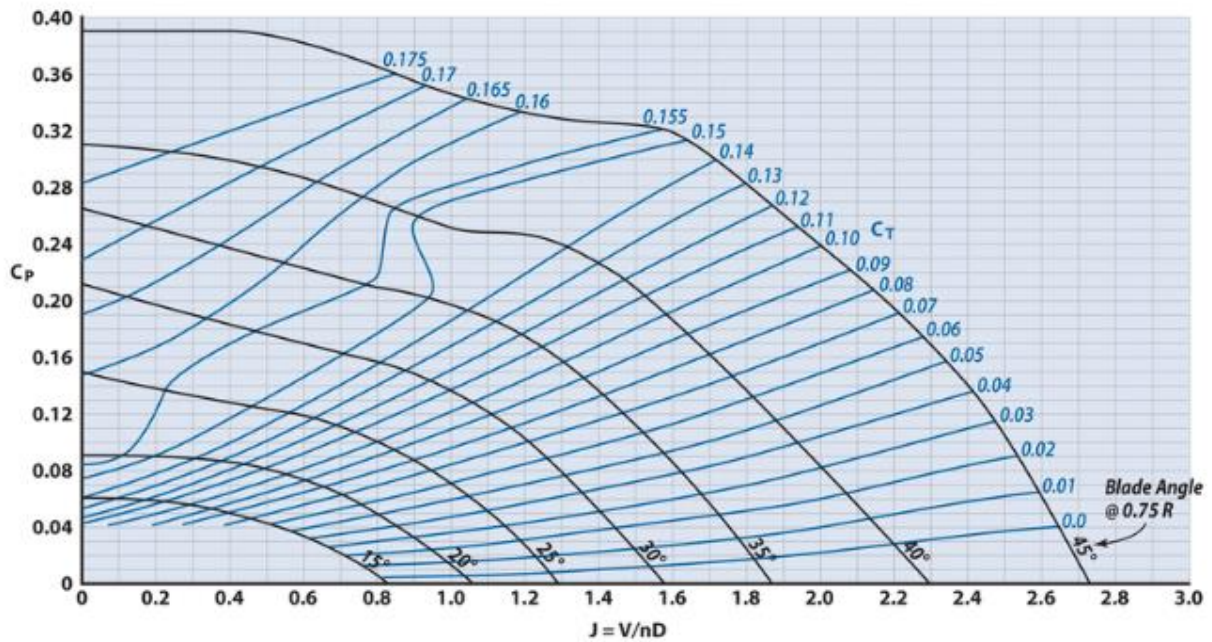

Figure 11: Example propeller performance chart for a 3-bladed propeller in air.

For the steering system for the initial conceptual design, a dual motor setup allows for each side of the propulsion system to be isolated, providing a few benefits. Dual motors enable thrust vectoring, reducing the need for a rudder. This decreases the surface area exposed to the water to reduce drag and system complexity. However, for differential thrust to be successful, the difference in thrust needs to have high moments acting on the vehicle to turn. If the vehicle cannot generate a large turning moment, it must make a large turning radius, which can reduce overall performance in the race where turning is expected.

In the final design, differential thrust led to problems in the controls causing extreme loading on the motors and ESC, resulting in high torque outputs and high bursts of current being drawn from the power supply. This motivated the use to reintroduce a rudder, since the loading is unacceptable when quickly shifting the controls from full throttle forwards to full throttle

backwards. The reintroduction of the rudder also improves the turning radius of the vehicle. For the rudder, an RC boat rudder controlled by a high torque servo motor was trivial to implement. There is an additional hole in the boat for the rudder cable, which is made from three strands music wire twisted together with a drill to create a reinforced cable, since bending of the wire would be catastrophic as it would cause the rudder to become ineffective. A 3D printed mount for the rudder servo was made, which can be seen in Figure 12.

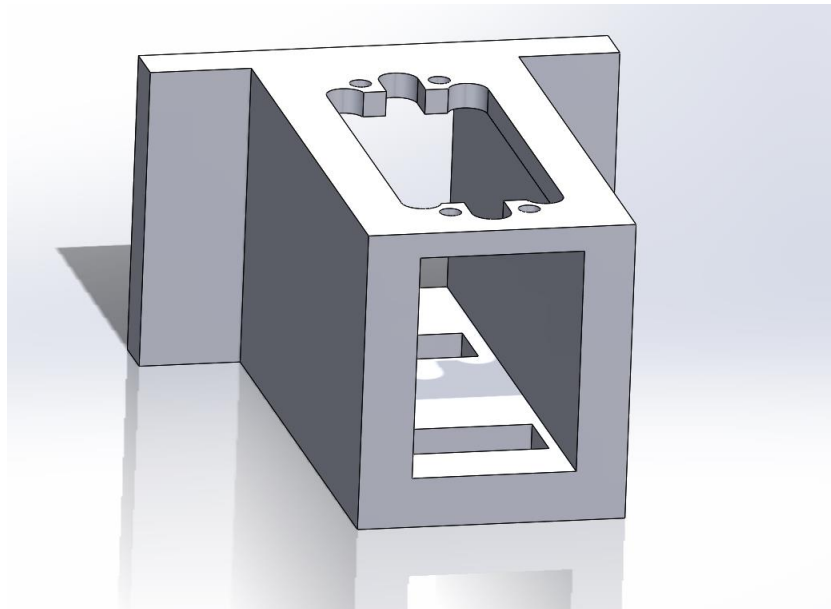

Figure 12: Rudder Servo Mount

7. Controls and Navigation

7.1 Pixhawk Controller

The control system for the electric boat is operated through Pixhawk and Mission Planner. A Pixhawk 6C Flight Controller controls the boat using Mission Planner, a software app typically

used for drone flight operation with ArduPilot firmware. ArduPilot is an open-source firmware for autopilot systems, supporting many vehicle types including multirotor drones, planes, helicopters, and rovers. The ArduRover variation of ArduPilot is ideal for the AMV, as it supports boat navigation. The relative ease in setting up connection and control through Mission Planner as a Windows Application compared to, for example, coding in Raspberry Pi or ROS with the possible need for a minicomputer, is why a Pixhawk is preferred for the controls system.

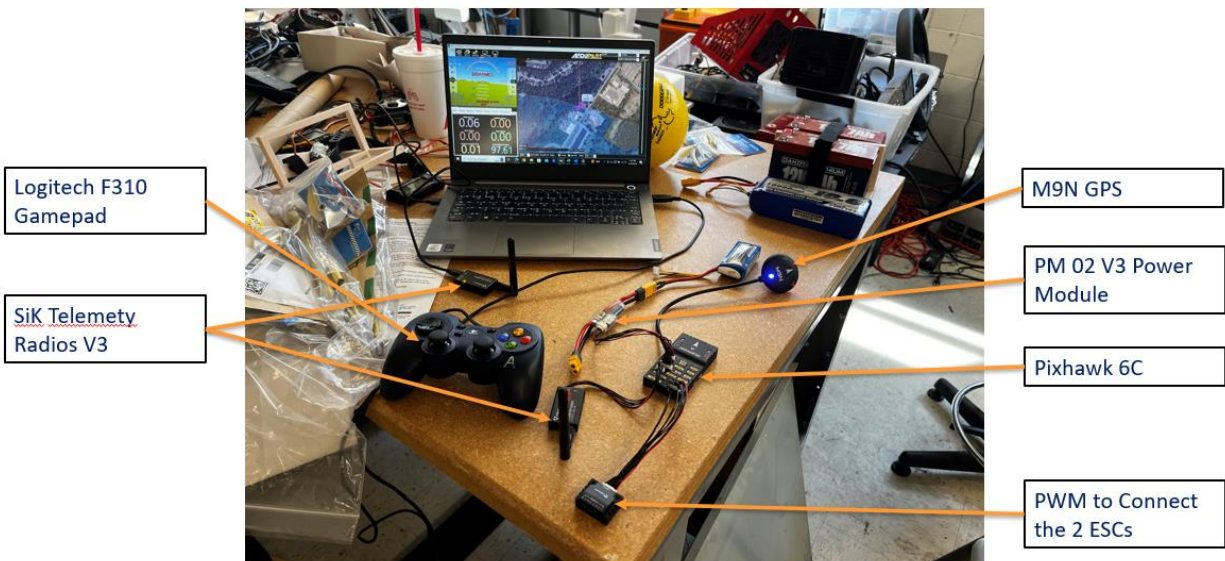

Figure 13: Complete Controls System involving Pixhawk Flight Controller & Mission Planner

Multiple components are plugged into the Pixhawk 6C such as GPS, telemetry radio, battery, and a PWM module which can be seen in Figure 13. The flight controller comes with the M9N GPS, which allows for the current location of the boat to be tracked through Mission Planner. It also enables automatic waypoint missions through Mission Planner to be performed in future iterations of the design. The Holybro SiK Telemetry Radio V3 permits communication between the Pixhawk in the boat and Ground Station within Mission Planner. With a range of 300 meters, the radio provides operational information such as speed, direction, voltage, and temperature of

the two ESCs in use. Furthermore, not only are signals received to the Ground Station from the flight controller, but the telemetry radios can also send input signals, allowing for the use of a Logitech F310 Gamepad Controller to throttle and steer the boat.

For controls, everything is compatible with the open source PixHawk control architecture, which is extremely common in airborne drones and a variety of hobby RC vehicles. The advantage of the PixHawk is the wide variety of compatible sensors and options for other modules, such as connections to Raspberry Pi, Arduino microcontrollers, and other minicomputers to perform other tasks such as path planning. In addition to its full internal IMUs and navigation suite that is open source, the PixHawk suite is a powerful and cheap solution for control combining radio capability with navigation. It is powered by its own battery connected to a step-down voltage circuit and connector adapter called the BEC, or battery eliminator circuit, which is usually used in drones to eliminate the need for a separate battery. It also uses a GPS to correct errors that can arise in its inertial measurement unit used to track vehicle position. With the final setup, the PixHawk is able to run ArduRover, which allows for the twin motor setup to use both motors in a thrust vectoring setup to turn, removing the need for a rudder.

7.2 Control System

Building the control system with Pixhawk is simple. The flight controller allows components to be plugged into it with GHR connection cables. Connecting the Pixhawk to power from a laptop, ArduRover firmware is downloaded into the flight controller, and the compass on the M9N GPS is calibrated to ensure accurate location reading. The calibration process is straightforward, simply pointing and angling the GPS in multiple directions to obtain the full range. To enable Pixhawk to send information without direct connection to laptop, the Sik Telemetry V3

Radios must be set up in Mission Planner and paired together. The GHR connection to Pixhawk provides both power and communication for one of the radios. The other radio is connected directly to the Laptop through USB. With a separate battery powering the Pixhawk through a power module, the two radios establish a signal between Ground Station and the vessel using two-way duplex communication. Rather than needing an RC receiver with a radio controller, a Logitech F310 Gamepad Controller can be connected by USB to a laptop and achieve the same result. The joysticks and buttons on the controller map to different functions on the boat, including arming, disarming, throttle, and steering, as shown below in Figure 14:



Figure 14: Mapping of Controls on Logitech Gamepad

8. Thermal Management System

8.1 Cooling System

A large part of any motorized system is cooling. Without proper cooling, the boat will still run, but the risk of overheating and stalling out in the middle of the water increases significantly.

The components inside the hull that are most imperative to cool are the motors and ESCs. To solve this problem, a process of circulating water throughout the hull is described. Attached to the bottom of the hull is a cooling mount, which funnels in water from the outside of the hull and sends the water through surgical tubing into the hull to be circulated to various components inside.

For thermal management, passive cooling is used, which relies on the forward motion of the boat to cycle water to cool the motors and the ESCs. From testing, the motor produces the highest amount of heat after sustained testing with no load, so sealed conduction water jackets are utilized to remove heat from the motors by circulating water around the outer surface of the motor. The cooling tubes wrap outside the boat on the underside, where there is a mount for the tubes aligned with the laminar flow under the boat.

One of the issues with the hull is the black of the exterior, which absorbs heat compared to other colors like white. This means that the boat tends to get hotter more quickly, increasing the internal ambient temperature. Since the boat is sealed, and the water jackets primarily cool the motors and ESCs, the ambient temperatures remain higher, which can slightly decrease the performance of the boat and slightly increases the risk of the boat overheating. Future teams should avoid using a dark exterior and choose a lighter color such as white.

8.2 Cooling Mount

The mount was created through 3D printing, and the CAD of the mount is shown in Figures 15 and 16 below.

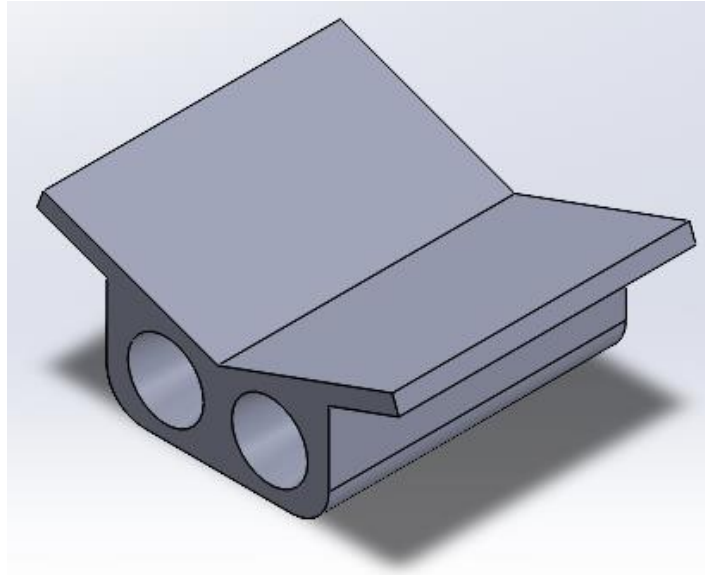

Figure 15: 3D Printed Cooling Mount Isometric View

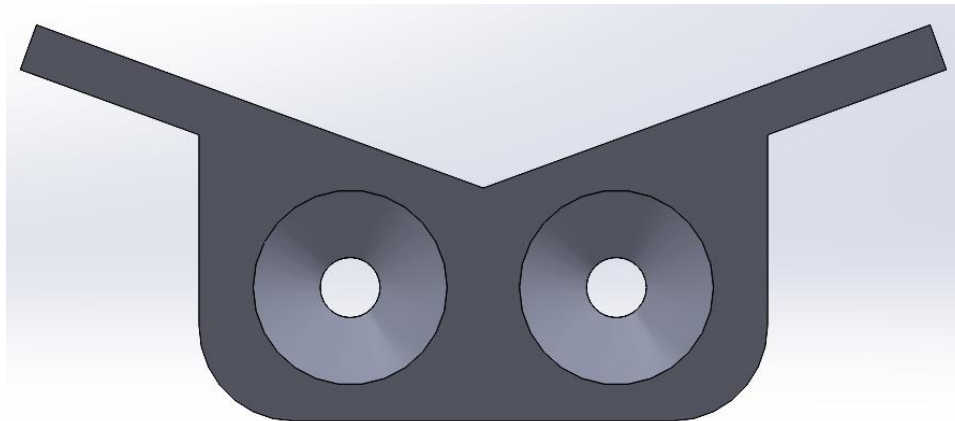

Figure 16: Cooling Mount Front View

Once inside the hull, the water is circulated through surgical tubing into water jackets surrounding the motors. The water flows into the jacket, actively cooling the motors, as the water temperature is lower than the motor temperature, before flowing out of the jacket to the ESCs. Upon movement through both the water jackets and ESCs, the water is propelled out the back of the boat into the surroundings. The system is pictured below in Figure 17 below:

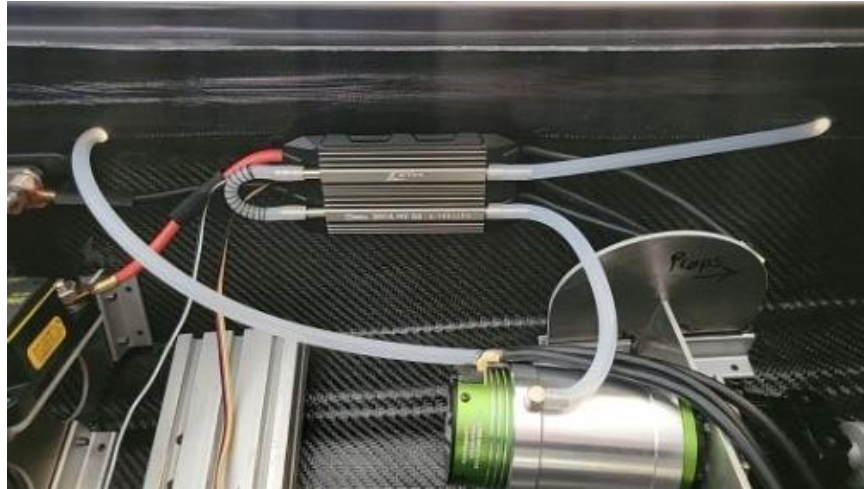

Figure 17: Cooling Loop Between the Motor and ESC

9. Final Design

9.1 Competition Design

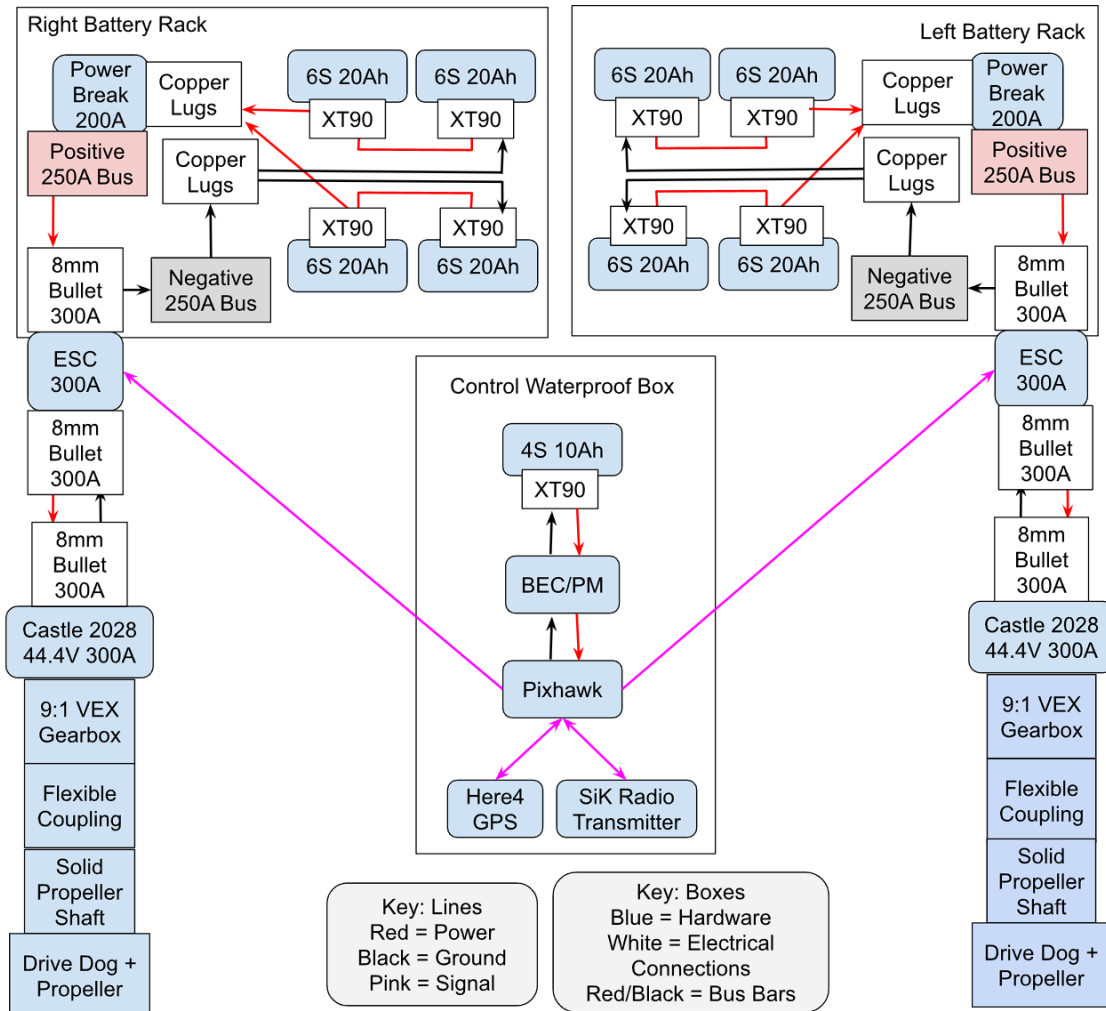

Figure 18: Competition System Diagram of Hardware and Electronic Components

Figure 18 shows the system diagram for the competition and the layout of how electrical stored energy in the battery is ultimately converted into thrust. This configuration combines readily available commercial products for RC boats that combine budget costs with high power to meet

the target specifications for the competition that exceeds the performance of the expected opponents.

For the competition design, the final hull hardware specifications are listed in Table 9.

Metric	Specifications
Hull Type	Displacement V-Hull
Hull Material	Carbon Fiber
Structural Material	Aluminum
Weight	< 100 lb
Total Battery Count	8
Total Battery Configuration	Twin banks of 2S2P
Battery Type	6S LiPo
Nominal Voltage	44.4 V
Maximum Voltage	50.4 V
Battery Capacity	20000 mAh
Battery Bank Capacity	40000 mAh
Total System Capacity	80000 mAh
Battery Max Current	100 A
System Maximum Current	200 A
Bus Bar Maximum Current	250 A
Circuit Breaker Rating	200 A
Motor Configuration	Twin
Motor Type	Brushless DC Motor
Motor Kv	800 Kv
Motor Free RPM @ Max Voltage	40,000 RPM
Max Motor Power	10,000 W or 13.4 hp
Total Max Power	20,000 W or 26.8 hp
ESC Rating	12S up to 300A
Powertrain	9:1 Gearbox + Flexible Coupling
Shaft Type	Solid Steel
Shaft Diameter	¼"
Propulsion Sealing Method	Stuffing Box
Propeller	4" Diameter, 5 Pitch Aluminum Propeller
Propeller RPM @ Max Voltage	4500 RPM
Controller	Pixhawk 6C

Controller Battery	4S 10 Ah LiPo with BEC
Control Scheme	Differential Thrust
Thermal Management	Twin Passive Open Loop Cooling

Table 9: AMV Competition Design Hardware Specifications

Assembly of the systems leads to the completed hull, which can be readied for competition.

Pictures showing the completed hull are below in Figures 19, 20, and 21.

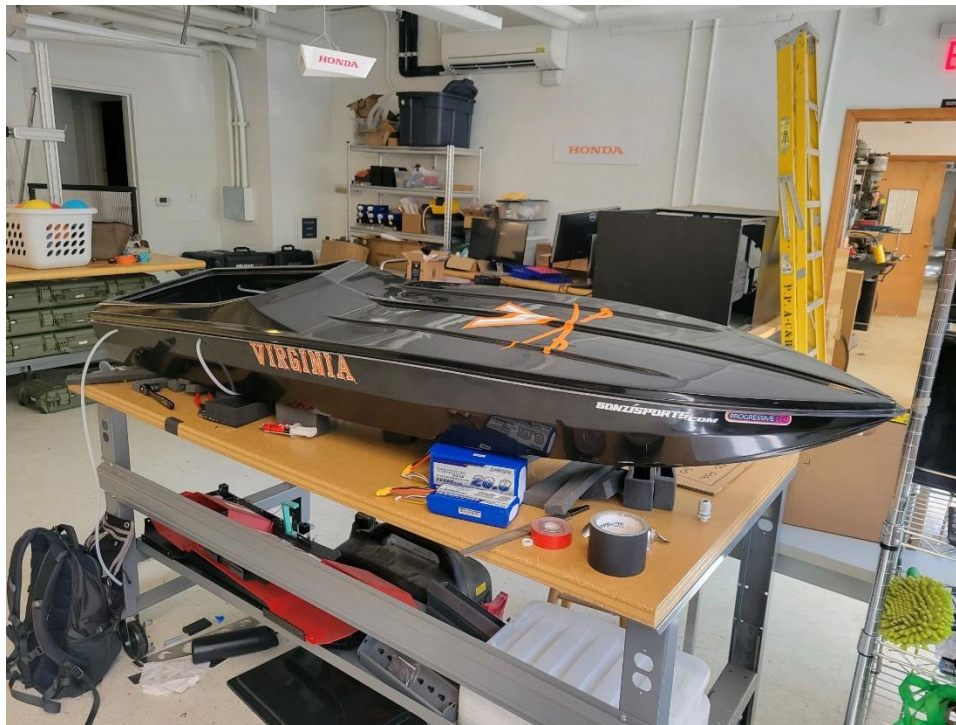

Figure 19: Outside View of Hull



Figure 20: View of the Drivetrain and Navigation Systems



Figure 21: View of the Batteries and Fuses in Position

9.2 Experimental Validation and Testing

Several forms of testing can be used to validate the system. A series of dry tests are completed to make sure the internal components, such as the motors, gearboxes, and shafts, spin and allow the boat to be thrust forward through the water. To prepare, the boat is propped up on a table and the area was cleaned up to allow for the propellers to spin safely. While there were setbacks caused by a de-soldering of an ESC wire and a lack of grease on the shafts connecting the motors to the propellers, the testing was successful. The motors spun for up to a minute at a time, and the system did not overheat and performed as expected.

The next series of tests involved in-water testing. The boat's buoyancy was tested before components were installed, and it could stay afloat with up to 120 pounds of water inside. The completed system, even with heavy batteries, did not come close to reaching that number, as the boat weighed a maximum of 80 pounds. Therefore, it was decided that the boat would not sink in the competition due to weight.

The next test involved the turning and propulsion capabilities of the vehicle. Shown in Figure 22 is the boat in the water being tested. This testing was completed without using full throttle of the motors. Even so, the boat had significant power to move through the water. Even though there was no rudder on the back, it still turned well both with and against the current, validating the decision to use torque vectoring. Following these tests, the boat was considered ready for competition.



Figure 22: Boat Testing in Water

Figure 23 shows some of the experimental data from the PixHawk that shows the control signals sent by the PixHawk controller to the ESCs, as well as the path of the vehicle measured by the inertial measurement unit. In the throttle signal graph, there are extremely steep changes between the idle position and the maximum throttle command. What this suggests is that the controller was not using any kind of adaptive control to reach its targeted value. This means as soon as the command was sent, the controller would immediately cause the ESC to drastically change its timing, resulting in huge loading on the ESC and other electrical components. From these graphs of the throttle response, a controller such as a PID controller might be beneficial as it would allow for the loads on the system to gradually increase, decreasing the overall stress and improving reliability.



Figure 23: Telemetry Data from the Competition

In addition to the controls, the competition highlighted some of the failure points of the system, namely the gearbox fusing to stall the motor, the ESC not triggering its emergency high current cutoff protection, the circuit breaker being insufficient in preventing burst currents from destroying the ESC, and the PixHawk being unable to sense the voltages and currents being sent to the ESC. While some of these issues were addressed in the post-competition upgrade package, some issues remain that will need to be resolved in the future.

9.3 Post Competition Design

The competition was certainly a learning experience for the team. During the 200m qualifying run for the competition, one of the gearboxes friction-welded itself together. However,

the ESC continued to send PWM signal values to spin the stalled motor. Unfortunately, the ESC did not have feedback from the motor, which was stalled because the gearbox was not turning. The ESC's signal requests from the Pixhawk flight controller were causing an inrush of current from the battery array to the ESC, which caused an internal board to detonate and start a fire in the hull. Thankfully, the BSU was able to shield the flames from the main battery array, which avoided a catastrophic failure. While most components were salvageable after the ESC loss, several design changes had to be made to avoid the problem from reoccurring.

The welding of the gearbox could have been caused by multiple smaller failures. Firstly, the hull of the boat is black in color, and the ambient temperature on competition day was almost 90°F - the components were therefore hot before the competition even began. Secondly, the gearbox itself was not internally pressurized, so the grease which had initially been applied to the internal planetary gears quickly became consumed by the high speed of the gearbox, and therefore no longer lubricated the gears effectively. This caused a rapid increase in temperature in the gearbox, which eventually caused the gears to fuse. Finally, the torque vectoring steering configuration causes the motors to quickly alternate from a state of full throttle forwards to a state of full throttle backwards based on the turning direction applied. This rapid switching with solid shafts could have caused the gearboxes to instantaneously weld themselves together. While the final cause of failure of the gearbox cannot be determined, several design alterations should prevent the boat from experiencing a similar event again.

First, it was decided that a rudder should be implemented rather than using torque vectoring for steering. With a rudder, direction can be altered using an RC servo motor to adjust the angle of attack of the rudder relative to the water flow under the hull. The servo can still be rotated using

the joysticks on the controller, but it will allow for both propellers to always spin forwards instead of using the direction of the motors to turn the vessel.

Additionally, the solid shaft drivetrain setup, including the gearboxes and flexible couplings, was abandoned in favor of a flexible shaft setup. Flexible shafts have significantly higher RPM limits than a solid shaft coupled to a flexible coupling, so there is no need for a gearbox. The flexible shafts allow for some bending during rotation, so the slight angle at which the tubing was installed to cause the propellers to be fully submerged does not cause any issues.

The post-competition hardware specifications with the new upgrades are listed below in Table 10 and the full final system diagram can be seen in Figure 24.

Metric	Specifications
Hull Type	Displacement V-Hull
Hull Material	Carbon Fiber
Structural Material	Aluminum
Weight	< 100 lb
Total Battery Count	8
Total Battery Configuration	Twin banks of 2S2P
Battery Type	6S LiPo
Nominal Voltage	44.4 V
Maximum Voltage	50.4 V
Battery Capacity	20000 mAh
Battery Bank Capacity	40000 mAh
Total System Capacity	80000 mAh
Battery Max Current	100 A
System Maximum Current	200 A
Bus Bar Maximum Current	250 A
Circuit Breaker Rating	200 A
Motor Configuration	Twin
Motor Type	Brushless DC Motor
Motor Kv	800 Kv
Motor Free RPM @ Max Voltage	40,000 RPM
Max Motor Power	10,000 W or 13.4 hp

Total Max Power	20,000 W or 26.8 hp
ESC Rating	12S up to 300A
Powertrain	Direct Drive
Shaft Type	Flexible Shaft
Shaft Diameter	¼"
Propulsion Sealing Method	Stuffing Box
Propeller	72mm, 3.98" Pitch Aluminum Propeller
Propeller RPM @ Max Voltage	4500 RPM
Controller	Pixhawk 6C
Controller Battery	4S 10 Ah LiPo with BEC
Control Scheme	Forwards/Backwards Thrust + Rudder
Thermal Management	Twin Passive Open Loop Cooling

Table 10: AMV Post-Competition Design Hardware Specifications

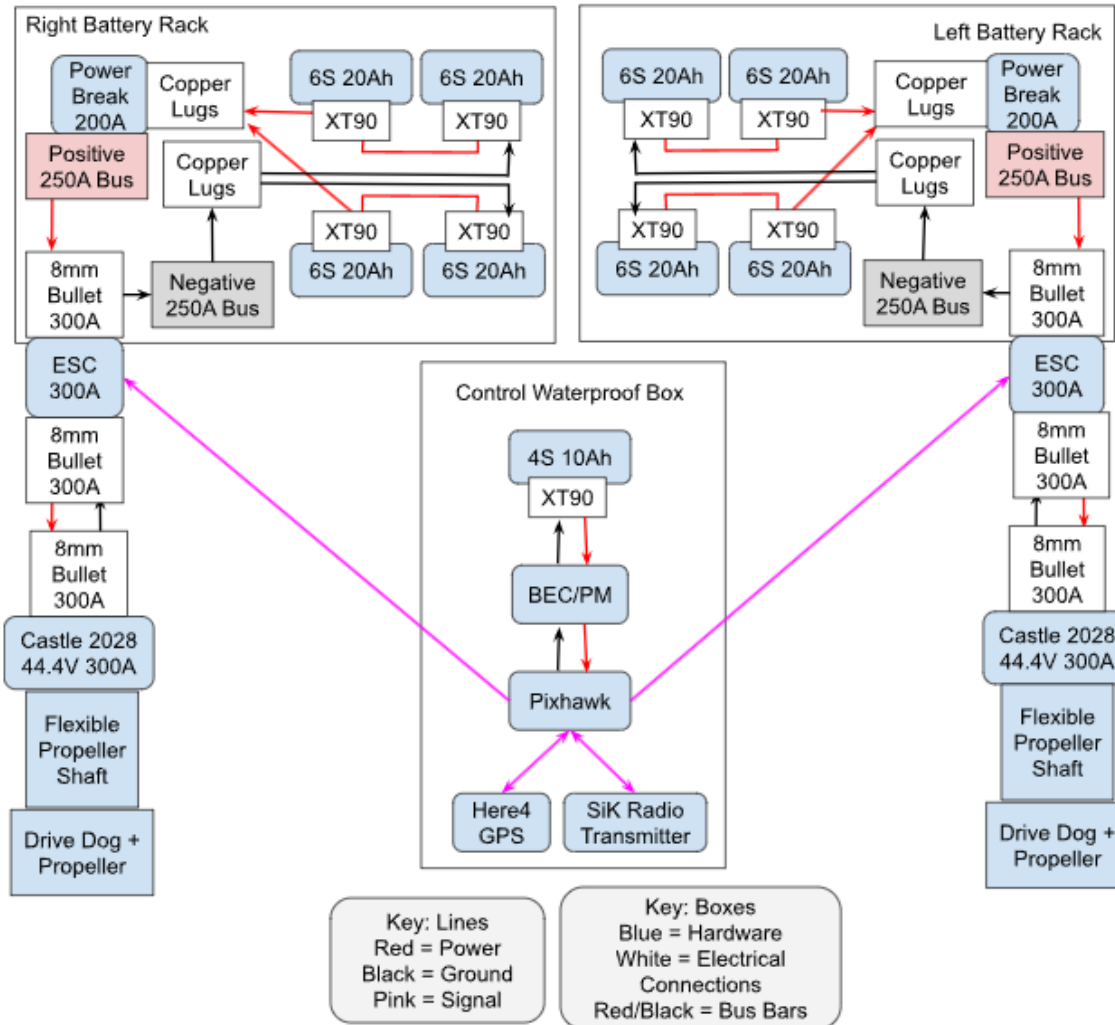

Figure 24: Post Competition System Diagram of Hardware and Electronic Components

Both changes were installed to the hull, shown in Figures 25 and 26. The rudder turned using a servo motor, which was attached to the inside of the hull, as expected. Flexible shafts spun more smoothly than the solid shafts, without needing to quickly change direction.

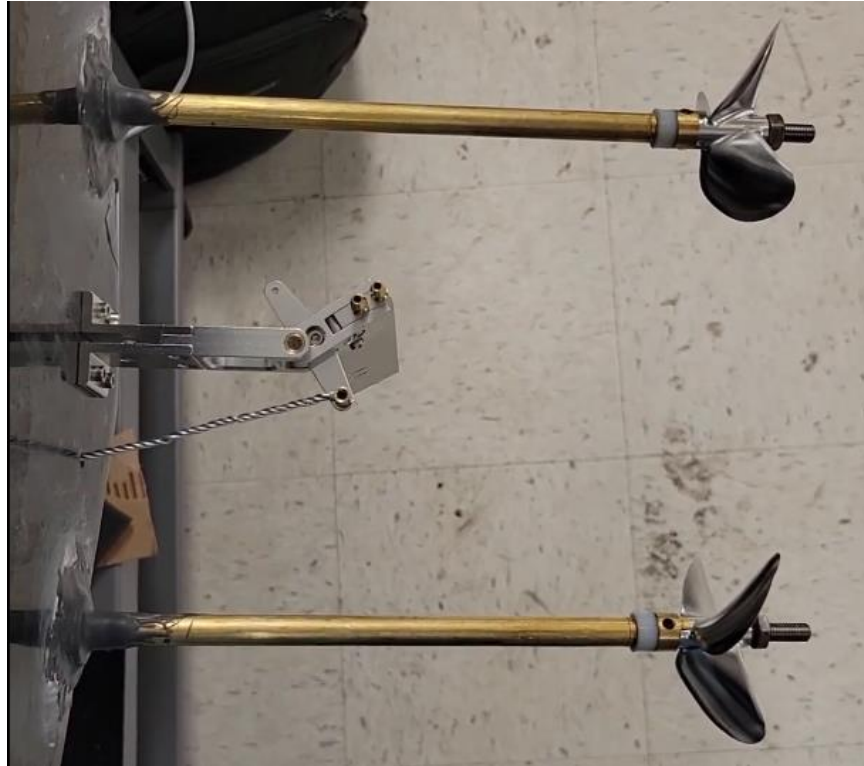

Figure 25: Rudder Installed on the Hull



Figure 26: Flexible Shafts Installed and Connected to Motors

Unfortunately, the hull could not be tested fully on the water. The seal was insufficient between the rudder wire and carbon fiber exterior of the hull, causing water to leak into the boat at a dangerous rate for the interior components. Therefore, the only testing completed was dry testing. Hopefully, future teams can seal the hole better and complete water testing more substantially to prove the effectiveness of the final design.

10. Conclusions and Future Work

Overall, the team was confident in the system put in place to lead the boat to victory. The power-to-weight ratio in the boat was incredibly high, and it was believed that the initial design had enough endurance and resilience to finish the five-mile course. However, on qualification day for the PEP competition, the 200-meter test was failed. Through analysis of the failure and conversations with other PEP participants in terms of designs, we were able to obtain better knowledge on improvements that can be made to our boat.

The following weeks were spent implementing the final design choices. The new parts were installed, and the boat was again placed in the water to correct the issues from the 2024 PEP competition. However, a failure to properly seal the wire connected to the rudder meant that the hull was not watertight. This caused the boat to be unable to complete a full five-mile course, once again.

Although the initial customer needs and project goals were not completely met, there are plenty of takeaways from working on this project for a year. To begin with, not all engineering projects succeed on their first attempt. In this case, the first attempt lasted 30 seconds on its qualifying run. Significant knowledge was gained from this failure, with a further understanding

of what design choices successful teams use, and what designs they typically avoid. Next, there is significant learning about project management. Ultimately, the failure of the AMV occurred at competition because of the lack of in-water testing that occurred in Charlottesville in the months leading up to the competition. The plan was to have the boat completed in March and save the month before the competition for testing; however, the actual assembly of the hull was behind schedule, leading to a lack of any testing.

Future teams working on this project can focus on several areas, most importantly autonomy. The final design proposed in this system uses the lowest level of autonomy, radio control. The system can use waypoint navigation for missions in its current setup. Further development can be done regarding this but also on developing an object detection system so that waypoints do not need to be set. Having a camera that scans for the buoy or point where a turn must be made can allow for complete autonomy of the system from humans. Furthermore, future teams can do specific testing into propeller speed, center of gravity, and other measures on the boat to understand the system which will propel the boat at the fastest speed for the longest amount of time.

The system proposed here has immense capabilities if developed properly. With increased knowledge on the subject, future teams can look forward to transforming the future of electric autonomous travel around the world's bodies of water!

References

- American Society of Naval Engineers. (2024). *Promoting Electric Propulsion (PEP) for Small Craft*. Naval Engineers. <https://www.navalengineers.org/Education/Promoting-Electric-Propulsion-PEP>
- Antcliff, K. R., and Capristan, F. M., (2017). “Conceptual design of the parallel electric-gas architecture with Synergistic Utilization Scheme (Pegasus) concept,” 18th AIAA/ISSMO Multidisciplinary Analysis and Optimization Conference, 2017.
- ASNE. (2024). *Rules for 2022-2023 Promoting Electric Propulsion (PEP) Competition*. American Society of Naval Engineers. https://www.navalengineers.org/Portals/16/PEP/2024/PEP_Rules2023-2024draft.pdf
- Bell. (2024). How I Built the World’s Fastest Drone. Accessed May 9, 2024. https://www.youtube.com/watch?v=wThmg8Ezm9w&ab_channel=LukeMaximoBell
- BlueRobotics. (2023). BlueROV2. *Blue Robotics*. <https://bluerobotics.com/store/rov/bluerov2/>
- Buckland, Hannah C. et al. (2013) “Cavitation inception and simulation in blade element momentum theory for modelling tidal stream turbines” <https://journals.sagepub.com/doi/10.1177/0957650913477093>
- Bushey, R. (2016, March 30). *Ocean wave energy harvesting nets \$2 million Department of Energy grant*. Virginia Tech News. <https://news.vt.edu/articles/2016/03/032316-me-waveharvest.html>
- Carichner, G. E., & Nicolai, L. M. (2013). *Fundamentals of aircraft and Airship Design*. American Institute of aeronautics and astronautics.
- Dakota Lithium. (2024). *DAKOTA LITHIUM 48V 96AH DEEP CYCLE LIFEP04 BATTERY*. <https://dakotalithium.com/product/dakota-lithium-48v-96ah-deep-cycle-lifepo4-marine->

[battery/?gad_source=1&gclid=EAIaIQobChMIp6C0oMaBhgMVDktHAR1TDQIIEAQYASABEgLqO_D_BwE](https://www.researchgate.net/publication/325111111/battery/?gad_source=1&gclid=EAIaIQobChMIp6C0oMaBhgMVDktHAR1TDQIIEAQYASABEgLqO_D_BwE)

Freire, T., Sousa, D. M., & Branco, P. J. C. (2010, July). Aspects of modeling an electric boat propulsion system. In *2010 IEEE region 8 international conference on computational technologies in electrical and electronics engineering (SIBIRCON)* (pp. 812-817). IEEE.

Harbor Models. (2024). Shaft and stuffing tube assembly set.

Harper, J. (2023, November 6). Navy issues new RFI for large unmanned surface vessel.

DefenseScoop. <https://defensescoop.com/2023/11/06/navy-issues-new-rfi-for-large-unmanned-surface-vessel/>

Jiang, Y., Shao, S., & Hong, J. (2018). Experimental investigation of ventilated Supercavitation with Gas Jet Cavitator. *Physics of Fluids*, 30(1), 012103.

McMaster-Carr. (2024). Clamping Precision Flexible Shaft Couplings. Accessed on May 8, 2024.

<https://www.mcmaster.com/products/flexible-couplings/clamping-precision-flexible-shaft-couplings/>

Naqvi, A. A., Zahoor, A., Shaikh, A. A., Butt, F. A., Raza, F., & Ahad, I. U. (2022). Aprotic lithium air batteries with oxygen-selective membranes. *Materials for Renewable and Sustainable Energy*, 11(1), 33-46.

NASA. (2024, March 17). *State-of-the-art of Small Spacecraft Technology*. NASA.

<https://www.nasa.gov/smallsat-institute/sst-soa/>

NeuMotors. (2024). 2200/24 Series Brushless Motors. Accessed May 9, 2024.

<https://neumotors.com/brushless-motor-manufacturing/neumotors-2200-24-series-blcd-motors-2500-to-6400-watt-class/>

Pastra, C., Cinar, G., Mavris, D. (2022). Feasibility and benefit assessments of hybrid hydrogen fuel cell and battery configurations on a regional turboprop aircraft. *AIAA Aviation 2022 Forum*.

Sutin, A., Salloum, H., DeLorme, M., Sedunov, N., Sedunov, A., & Tsionskiy, M. (2013). Stevens Passive Acoustic system for surface and underwater threat detection. *2013 IEEE International Conference on Technologies for Homeland Security (HST)*, 195–200.

<https://doi.org/10.1109/THS.2013.6698999>

Tilney-Volk, C., Babel, K., Crisanto, A., Richard, B., & Stauffer, P. (2023). *Co-Navigational Aquaculture Vehicle System Design*. University of Virginia Department of Mechanical and Aerospace Engineering.

Turnigy Power Systems. (2024). Turnigy High Capacity 20000mAh 6S 12C Lipo Pack w/XT90.

<https://hobbyking.com/en-us/turnigy-high-capacity-battery-20000mah-6s-12c-drone-lipo-pack-xt90.html>

Appendix A: LiPo Battery Safety

Prework on LiPo Safety Guidelines:

- Please follow all LiPo safety rules when charging, discharging, balancing, and running in parallel.
- Expert safety guidelines can be found online.
- Check all battery cells using a cell voltage monitor device. Ensure that all LiPo batteries are at least 50% charged for usage with less than 0.1 V difference between batteries, and do not leave batteries in storage at a charge of higher than 4.0 V for prolonged periods.
- Return batteries to storage charge of around 3.8-3.9 V if prolonged use is not expected.
- Each pair of batteries that will go into the boat must have less than this 0.1 V difference for safety.
- Charge batteries individually to achieve this balance for every pair of batteries. Do not charge batteries more than 4.19 V or discharge them more than 3.5 V or else it could risk a fire.
- Do not 6-parallel charge the batteries if there is more than a 0.1 V difference between the highest and lowest voltage batteries.
- Charge outlier batteries to achieve this voltage spread and use good judgement when sizing amp loads through the wires being used.
- Never leave charging or discharging batteries unattended.

Hazard Warnings: Have a fire extinguisher nearby during operations. Do not use severely damaged LiPo batteries and exercise caution when handling and transporting. Do not touch two leads of a live circuit together (positive and negative terminal wires). Exercise caution when proceeding near live circuits and ensure that all busbars have the positive and negative terminals appropriately grouped. Do not let water short circuit any exposed electrical connections.

Tools for LiPo Battery Charging:

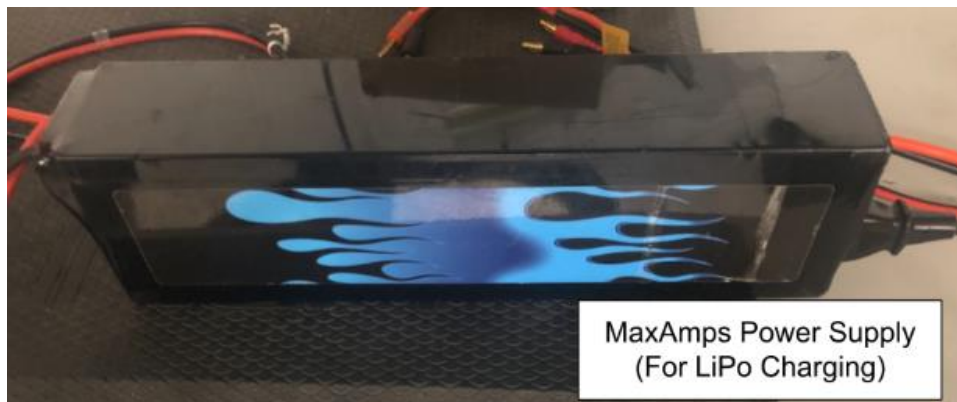
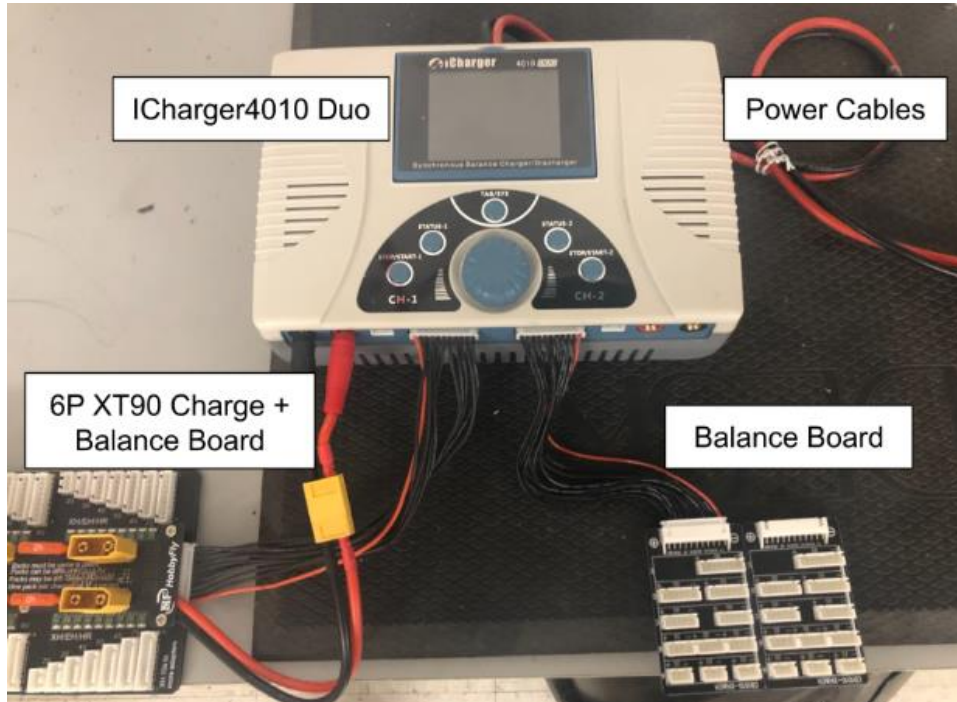

How to Charge a LiPo Battery

1. Check if the battery: Check using one of the many battery checkers. Note that you need to have all the pins of the battery balance cable touch the pins of the checker, or else it would detect. Remember, don't use puffy batteries, they can be a fire hazard.



2. Assess the battery: Remember LiPo batteries have a min voltage of around ~3.6V and max of ~4.1V in the safe range. To get the nominal voltage, multiply $3.7 * S$ to get your voltage. You shouldn't go lower than 3.7V because it reduces the lifespan of the battery a little.

3. Prepare the charger: If you are using an XT90 battery like the one pictured above, use a XT90 charging cable with banana plugs and plug it in to the charger. Get a balance board and plug it into the straight balance port.

4. Turn on the charger: To turn it on, find a safe power supply, like the MaxAmps power supply shown above. First, connect the positive and negative leads of the battery charger to the MaxAmps power supply. Then plug in the power supply to a wall socket or power strip. To turn off the system, just unplug the power supply.

5. Plug in the battery: Plug in the balance cable into the balance board with the correct length (snug fit) and plug the XT90 connector to the XT90 charger cable. The cables can only go in one direction.



6. Setup the charger: There are two sides, make sure you are using the correct side using tab, it will highlight which side you are “working” on. You can use the buttons, the big scroll wheel, and press down on the scroll wheel.



7. Navigate the Menus: Tap the big wheel once, it will bring up the battery chemistries (default LiPo). Then Tap the big wheel again to select LiPo and go to the charge menu.

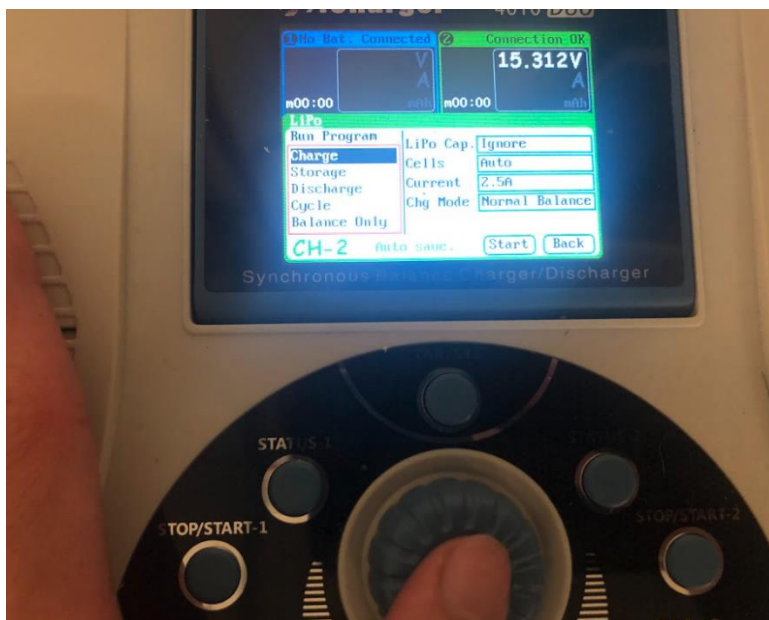

8. If you are satisfied with the Amps, then click the button to confirm: Rule of thumb, safe amps charge is always less than $1 \times \text{Ah}$ capacity. Recommend like $0.5 \times \text{Ah}$, better for the battery but double the charge time. Never exceed 12A because of the wire thickness on the power supply.



8b. If you are not satisfied with the amps: click the “Tab” button to switch from confirm mode to choose mode, and use the big wheel to choose the amps. Press the big wheel down to select the amps, then use the wheel to adjust. Reverse this process to go back to the Charge option and start charging.

Parallel Charging 6 batteries: Very dangerous.

1. Line up all your batteries of the same cell count and capacity (for safety).
2. Check the voltage of each, and order the voltages from low to high.
3. Using the ordered batteries, choose a set of 6 batteries. Check the highest and lowest batteries and make sure that the difference in total voltage (for safety) is less than 0.1V. If the difference is greater, then check a different set of 6 batteries.
4. If you do not have a set of 6 batteries that is valid, charge the lowest one of the set of 6 INDIVIDUALLY with the XT90 cable, then try to get it within the other 5 batteries. Repeat until all 6 batteries are close to each other.



5. Once you have 6 batteries, plug the parallel board into the iCharger
6. Plug in each battery starting from the lowest voltage into the parallel board. Either of the two plugs to go first is fine.
7. Charge the batteries as normal. The charger will think you are charging a single battery. You can increase the charge amps up to 12A but do not exceed 12A.

Appendix B: Operations Manual

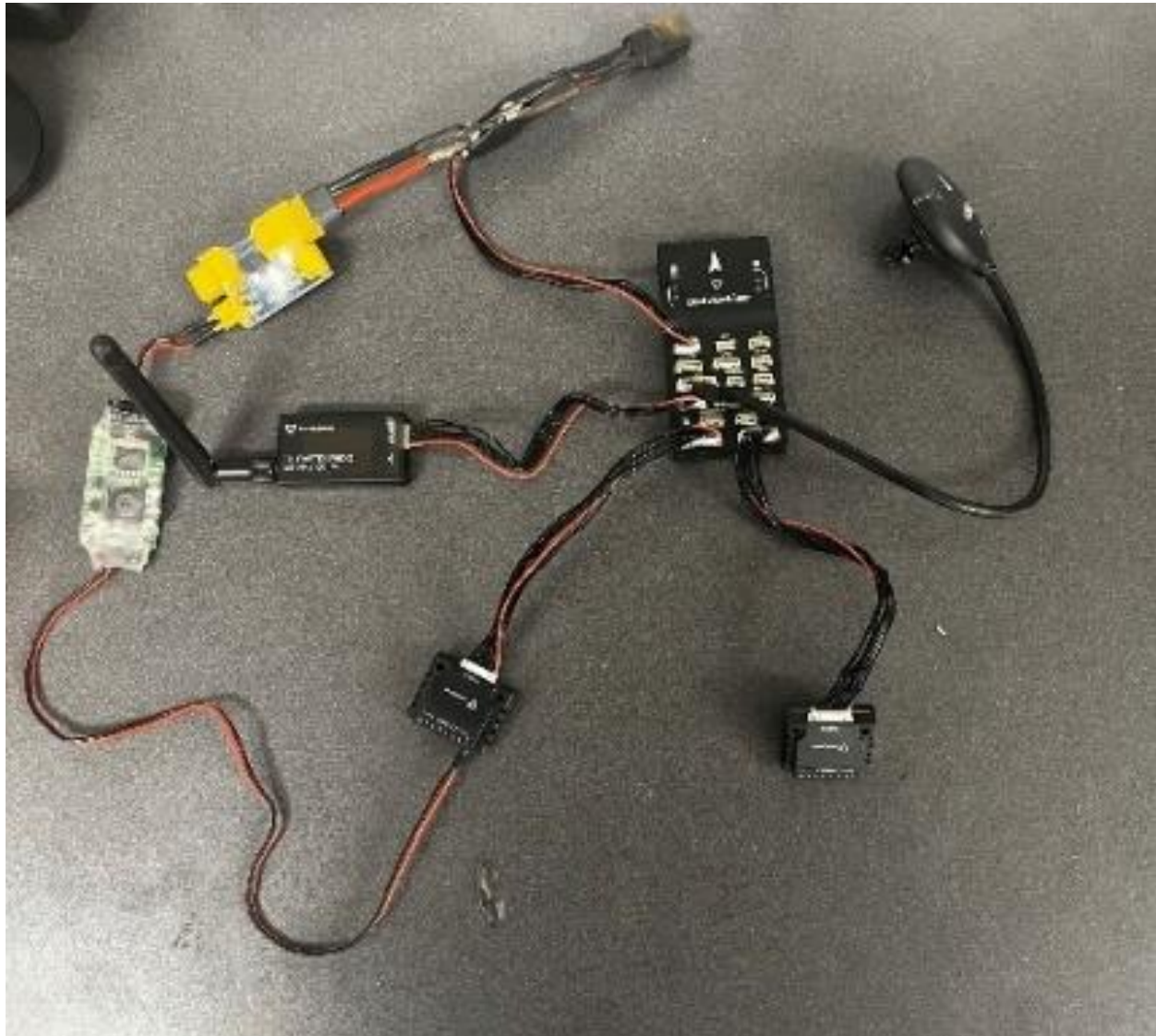
Pixhawk: The Pixhawk 6C flight controller allows for multiple components to be plugged in through JST-GH cables. The components are listed along with a wiring diagram on the next two pages. Picture below shows how connections are made outside of the Tupperware box.



Control System Components

<p>PM02 Power Module</p> 	<p>PWM Devices (2)</p> 	<p>M9N GPS</p> 
<p>Seal G2 Series ESC: 300A (2)</p> 	<p>SiK Telemetry Radio V3 (2)</p> 	<p>Pixhawk 6C</p> 
<p>Turnigy BEC</p> 	<p>20 kg-cm Servo Motor</p> 	<p>Rudder</p> 

Pixhawk Connection Guide

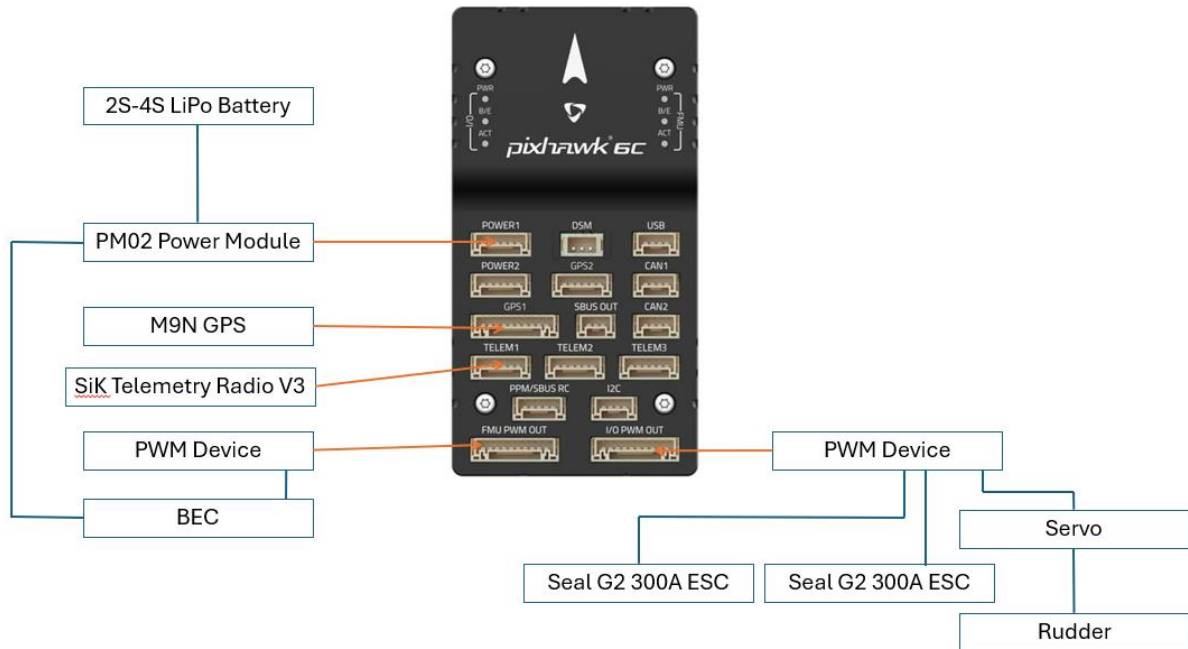

Operation

1: Open the lid of the hull and connect a 2s or 4s LiPo battery to the power module with XT60 connector, then use JST-GH cable to connect from power module to PixHawk 6C.



2: Connect the other XT60 connector on power module to the power board for the battery eliminator circuit (BEC) for servo motor.

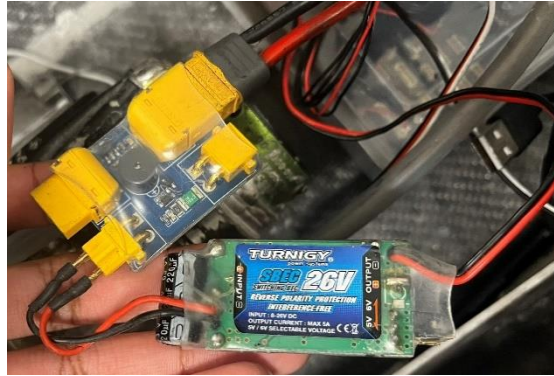

3: Connect wires between ESC and motors and cover heat shrink over points of connection. Then connect 4 pairs of 6s 20000 mAh LiPo batteries to XT90 connectors to busbars in parallel, 8 batteries in total should be connected. Place batteries on mounts with the wires side up for best connectivity.



4: Obtain a Logitech F310 Gamepad Controller & one of the SiK Telemetry Radio V3.



- 5: Connect both the controller and telemetry radio to laptop by USB.
- 6: Open Mission Planner app on Windows laptop.
- 7: In the top right corner, select the COM import in which the telemetry radio is plugged into on laptop and in the adjacent dropdown select the rate of 57600, then select “CONNECT”.
- 8: There are 8 ports on the PWM device, ensure the ESCs’ wires (white and black) are connected to ports 2 & 3 for Throttle, with the servo wire (white, orange, black) connected to port 1 for GroundSteering and that the PWM device for them is connected to “I/O PWM OUT” on Pixhawk. For the other PWM device connected to “FMU PWM OUT” on Pixhawk, check that BEC wire (black and red) is connected to port 1, matching the servo.

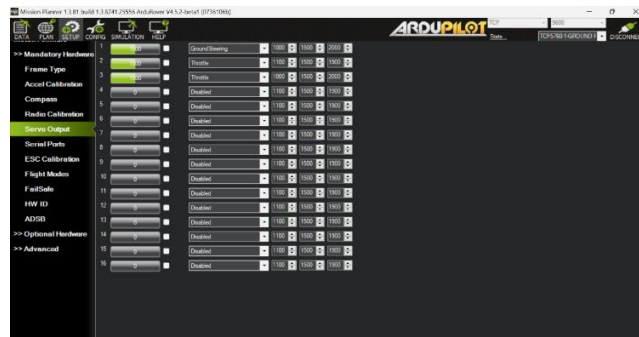

- 9: Switch the two circuit breakers to ON. You should hear the two ESCs calibrate with the following noise: “beep---beep...beep-beep!”. After calibration, put the lid on.



10: Under Actions, click on “joystick” and ensure left analog stick is mapped on Y axis for throttle for both motors and the right analog stick is mapped on Z axis for steering with the rudder, matching the servo output and PWM port plug-ins. Click ‘Enable’ to activate joystick.

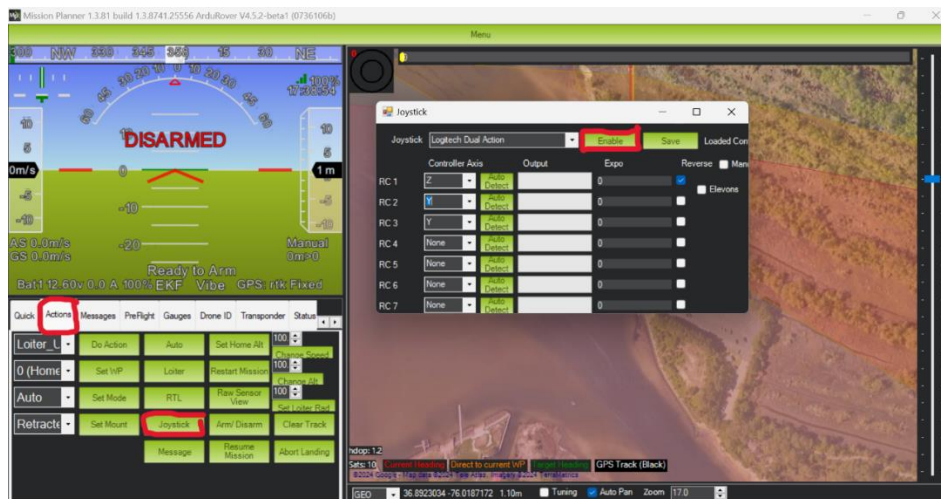

11: To arm, press the start button on the gamepad controller, OR click the Arm/Disarm under “Actions” tab in Mission Planner. For throttle input to go forward or backwards, go up/down on the left analog stick. For steering, go left/right on the right analog stick and the rudder should move.

12: To stop the operation of the boat, press the back button on the gamepad to disarm, OR click the Arm/Disarm button under “Actions” tab in Mission Planner. Then, select “DISCONNECT” in the top right corner.

13: Open lid, switch circuit breakers to off, avoid touching the busbars.

14: Disconnect 6s batteries from XT90 connectors.

15: Disconnect 2s/4s battery from Pixhawk and BEC.

Troubleshooting

Problem	Potential Fix
No noise from ESCs/no calibration on startup	<ul style="list-style-type: none"> • Ensure soldering connections are secure. • Make sure circuit breakers are switched to ON.
ESCs constantly beeping	<ul style="list-style-type: none"> • Check for trim in servo output is 1500, Min is 1200 and Max is 1900, ESCs should calibrate automatically.
Motors not spinning	<ul style="list-style-type: none"> • Check for firm soldering connections between ESC and motor. • Check PWM port connections
Rudder not responding	<ul style="list-style-type: none"> • Check that the servo connection is on the right port, correlating to servo output function in Mission Planner. • Ensure BEC is powered on (green light) and connected to matching servo output number on PWM device connected to FMU PWM OUT on Pixhawk.
Mission Planner Ground Station not connecting to Pixhawk.	<ul style="list-style-type: none"> • Check JST-GH Telemetry connection on Pixhawk. • Check COM selection in Mission Planner and match with COM telemetry radio detected in Device Manager on Windows. • Make sure the rate is 57600.
Pixhawk won't arm	<ul style="list-style-type: none"> • Check if joystick is enabled.