

Design and Construction of a Ferrofluid Kinetic Art Clock

Technical Capstone Project

Presented to the Faculty of the School of Engineering and Applied Science
University of Virginia, Department of Mechanical and Aerospace Engineering

Fall 2019

Conner Caruso
Christopher Fitzpatrick
Zachary Rosen
Alexander Rudin
Trevor Stutzman
Harrison Sublett
Eric Tang
David Xiao

On my honor as a University student, I have neither given nor received unauthorized aid on this assignment as defined by the Honor Guidelines for Thesis-Related Assignments.

Signed: _____

Approved:  _____ Date: April 22, 2020
Gavin T. Garner, Associate Professor, Department of Mechanical and Aerospace Engineering

Table of Contents

Abstract.....	3
Executive Summary.....	3
Prototyping.....	4
Initial Proposal.....	4
Prototype 1.....	5
Prototype 2a.....	8
Prototype 2b.....	13
Prototype 3.....	16
Prototype 4.....	17
Prototype 5.....	21
Prototype 6a.....	24
Prototype 6b.....	27
Prototype 7.....	29
Manufacturing.....	34
PLS6.75 Laser Cutter.....	34
Dimension uPrint 3D Printer.....	35
Programming.....	36
Future Work.....	37
Conclusion.....	38

Abstract

As a senior design project, the group elected to develop a piece of kinetic art in the form of a functional clock. The prospect of inspiring undergraduate engineering students with a mystifying display in the University of Virginia Mechanical and Aerospace Engineering Building initially motivated the group. The clock's mechatronic design incorporated aspects of software engineering, electrical engineering, and mechanical engineering. The project also created opportunities to practice prototyping skills, including problem identification, industrial-parts acquisition, computer-aided design (CAD), 3D printing, acrylic laser cutting, and iterative design. The group's finished product is a four-digit digital clock with a ferrofluid outward display.

Executive Summary

The project's initial vision was the use of selective magnet actuation that, when viewed from the audience's perspective, would create a mystifying effect while displaying the time. This initial vision transcended iterations of design. At a high level, initial prototypes included a blank central face. Every sixty seconds, ball bearings would dispense across the face. Selective positioning of hidden permanent magnets behind the face would give the bearings the appearance of floating in digital numeric arrangements that would collectively display the time. Ball-bearing related prototyping culminated with a system of servo-motor powered, linearly moving permanent magnets behind the central clock face and a cylindrical drum and reservoir that would ascend and descend across the front of the face to dispense ball bearings. Due to the project's financial and time constraints, the team ultimately favored a ferrofluid clock display,

which simplified the necessary functional components to magnet actuation and ferrofluid interaction. The magnetic actuation system was preserved, and the team exchanged the ball-bearing dispenser's complexities for a watertight ferrofluid tank. Experimentation of ferrofluid's chemical interactions with both carrier fluids and compartment walls followed until pre-manufactured ferrofluid-filled glass containers were acquired. The scope of prototypes was limited to an individual clock digit in order to analyze performance at a relatively rapid rate. After the group finalized a single-digit prototype, and upon its approval by the technical advisor, the prototype quadrupled in scale in order to compose an entire functional clock.

Prototyping

Initial Proposal

The project group initially intended to construct a piece of kinetic art that would display time by levitating ball bearings in numeric patterns through magnetism. Ferromagnetic ball bearings would cascade from a reservoir down a blank wall, or "clock face", via a trap-door mechanism, and electromagnets hidden behind the wall would selectively activate to attract the bearings in the air in patterns of digital numbers. Ball bearings that would fall sufficiently far from an activated magnet would continue to fall into a hopper below the clock face. After the duration of one minute, all magnets would deactivate and all previously attracted bearings would fall into the hopper. A resetting mechanism, such as a corkscrew or escalator-type machine, would then carry the ball bearings from the hopper into the reservoir to repeat the procedure for the next minute's display. The magnet actuation system soon settled around the translation of permanent magnets rather than the activation of electromagnets to conserve electricity.

Prototype 1

Overview

The group divided the clock design into three broad sections: Actuation, Display, and Electronics. This prototype assessed the feasibility of translation of one permanent magnet via a servo motor.

Actuation

The initial prototype of the actuation system involved constructing a proof-of-concept prototype of the actuation of one permanent magnet. Laser-cut acrylic composed a hollow box to house the actuation system, as shown in the Solidworks model in Figure 1. A MG90S servo motor powered the movement of the magnet via lever-arm and guiding rod constructions which were 3D printed from ABS plastic; the servo motor spun a lever, which translated an arm via a pin joint, as shown in Figure 2. A 3D printed magnet holder secured the permanent magnet, and the guide rods constrained the magnet to linear motion. This servo motor and lever arm combination were oriented in a manner that maximized the system's mechanical advantage when the magnet was in its furthest extended position. Such a solution mitigated the concern that the magnetic attraction between ball bearings and permanent magnet would overpower the force of the motor.

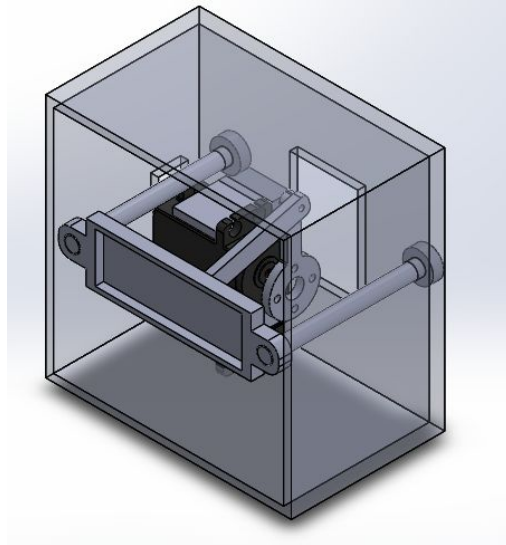

Figure 1: Solidworks model of single-magnet actuation system

Display

In order to isolate components, the display system for the initial prototype comprised of a sheet of paper taped to the front face of the acrylic box. To assess how well the ball bearings could be caught by the actuated magnet, bearings were dropped by hand across the paper face of the box. These initial tests proved that magnet could successfully catch the ball bearings, but a cluster of the ball bearings became magnetized and bunched up around the magnet, which decreased the resolution of the shape, as shown in Figure 2. In an effort to reduce this issue, $\frac{1}{4}$ -inch and $\frac{1}{8}$ -inch acrylic sheets were tested as alternative front faces in order to increase the distance between the magnet and the ball bearings. Eventually, $\frac{1}{8}$ inch acrylic was settled on as the preferred material both for aesthetics and resolution, but issues with bunching of the ball bearings persisted.

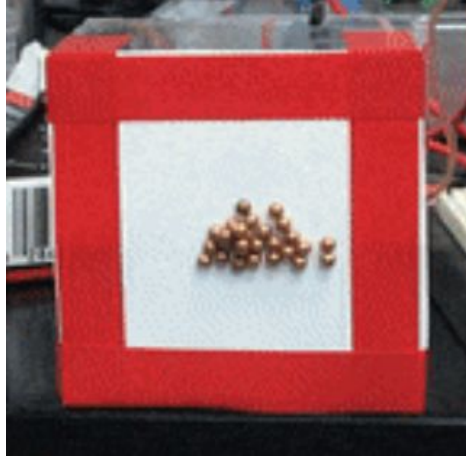

Figure 2: Example of ball bearing bunching on Prototype 1

Electronics

For this initial prototype, a Parallax Propeller microcontroller was used with an indicator LED, a 6.25 MHz oscillating crystal, and a 3.3V regulator. The servo motors were powered by a 6V external power source. This power source also powered the propeller chip through the 3.3V regulator. The microcontroller sent modulated pulses using the counter capability of the chip to vary the rotation of the servo motor, shown in Figure 3 below. The servo motor was simply moved from one position to another to move the magnet back and forth.

```
27 PUB MoveMotor (pin) | LowTime,period
28   `position should be between 50_000 and 225_000 (0 to 180 degrees)
29   dira[pin]~~~
30   ctra[5..0]:=pin
31   ctra[30..26]:=%00100
32   frqa:=1
33   position:=0
34   LowTime:=clkfreq/100
35   period:=cnt
36   repeat
37     phsa:=-position
38     period:=period+position*LowTime
39     waitcnt (period)
```

Figure 3: Parallax Spin method of moving servo motor with counter

Prototype 2a

Overview

Because the trial for one segment seemed practical, the group constructed the actuation assembly for an entire digit in Prototype 2. A housing of relatively durable $\frac{1}{4}$ -inch-thick acrylic surrounded the assembly.

Actuation

Because of the success of the one-magnet actuation mechanism, the next iteration of this component only involved augmenting its scale by a factor of seven such that an entire numerical digit could actuate. A box, cut from $\frac{1}{8}$ -inch acrylic, housed the assembly, as shown in Figure 4. Shown in Figure 5, the construction of the box involved dovetail designs along the edges of each wall, allowing interference fits to hold the walls together.

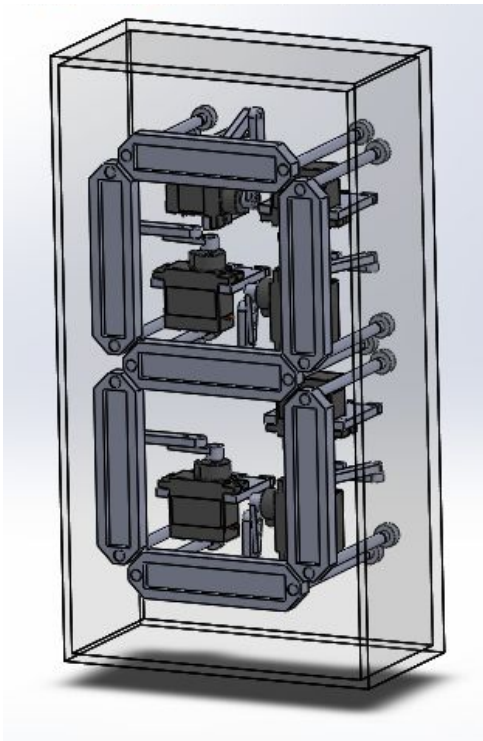

Figure 4: Solidworks model of a one-digit actuation system

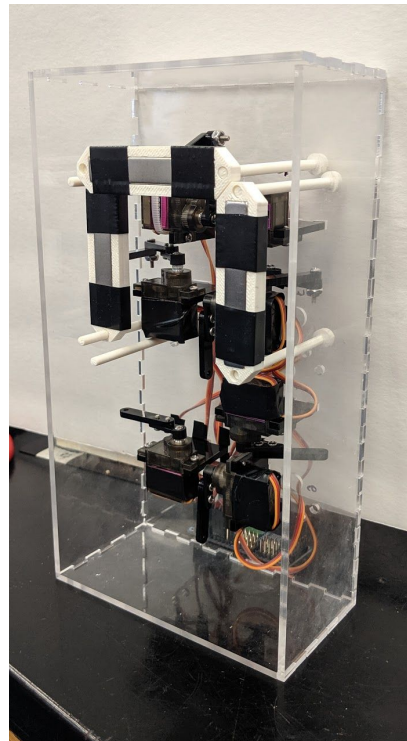

Figure 5: Partially assembled one-digit actuation system

The proximity of each magnet subassembly to one another posed a spatial challenge. Due to space constraints, a smaller RC servo motor model was chosen, the MG90. Alternating the orientations of the servo motor and lever arm in each magnet subassembly, as shown in Figure 4, allowed for a compact fit. This solution provided sufficient clearance to limit interactions between subassemblies while maintaining linear motion of each magnet holder.

Display

With the moderate success of the dropping-by-hand tests of Prototype 1, the group designed a preliminary dispensing mechanism that would mount above the clock face. Inspired by a revolving door, the mechanism involved a reservoir that would feed into an axially rotating drum, which would dispense ball bearings along the plane of the clock face, as shown in Figure 6.

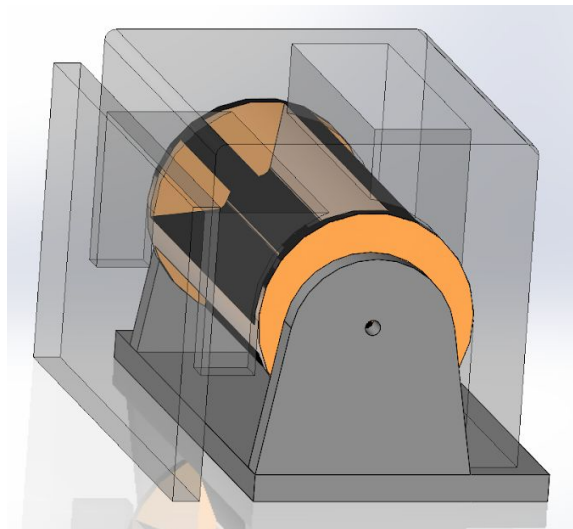

Figure 6: Solidworks model of top-mounted dispensing mechanism

The choice of a rotating drum rather than a trap door intended to mitigate potential malfunctioning of the dispensing mechanism; the group feared that ball bearings could catch at a trap door's interface and interfere with functionality. With this design, ball bearings would

simply fall from above the clock face, but the resolution problem identified in Prototype 1 remained unaddressed.

Electronics

In addition to the propeller microcontroller discussed in Prototype 1, Prototype 2 utilized a 16-channel Servo Driver chip as shown in Figure 7 below. This chip utilized an I2C protocol which allowed the Propeller chip to control 16 servo motors from just 2 output pins.

Additionally, up to 62 of these servo driver chips could be connected, allowing these 2 pins to control up to 992 servo motors at once. The chip utilizes 12-bit registers allowing for an extremely accurate resolution for the servo motors. This chip made it possible to easily and accurately control all servo motors required to make the clock work.

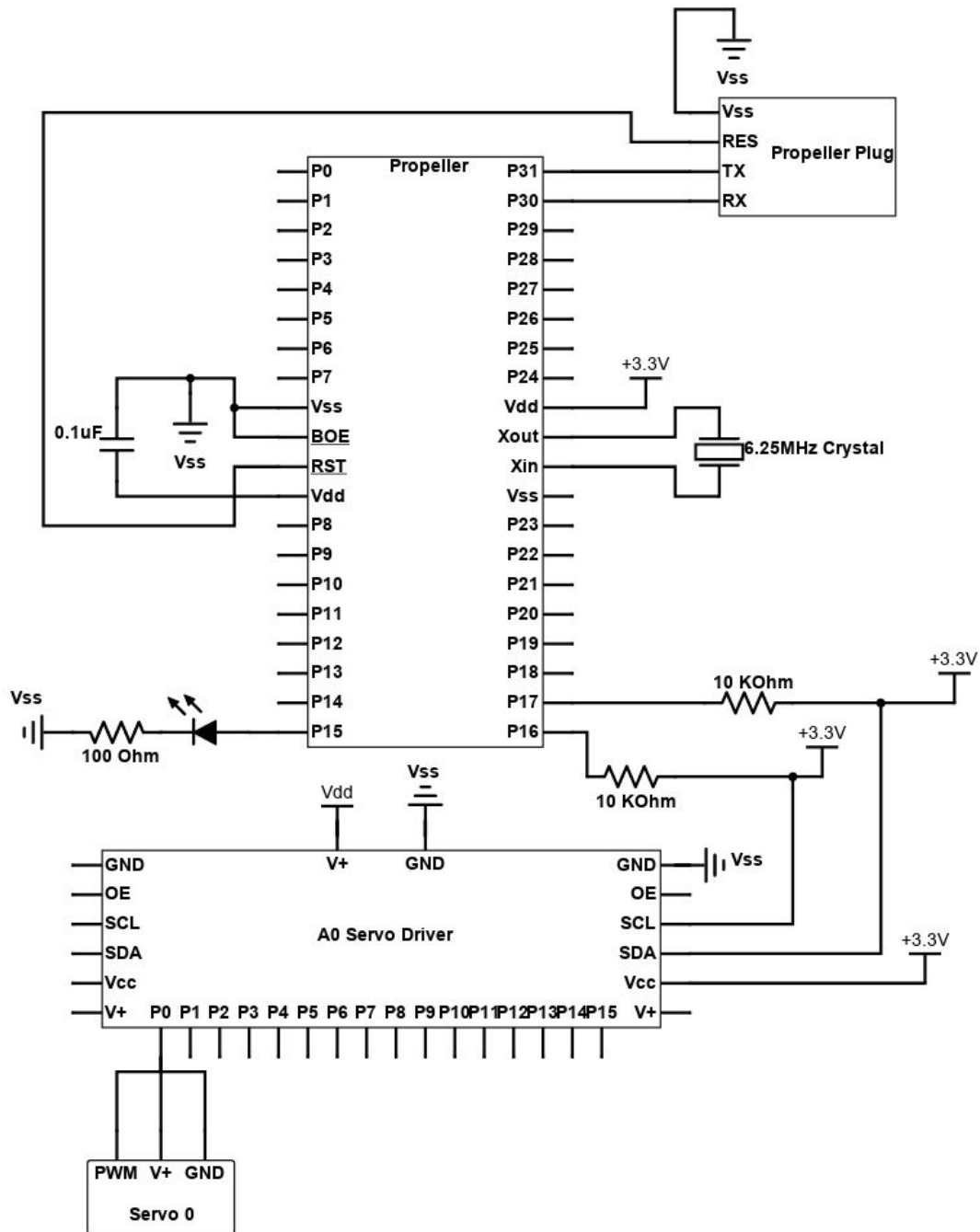

Figure 7: Prototype 2a Circuit Diagram

The servo driver was given a value between 0 and 4096 to move the motors back and forth. In addition, a mask was used for each number from 0 to 9 to determine which part of each

digit would be actuated forward to create each number. A standard numbering for each part of each digit was implemented to make moving each motor easier as shown in Figure 8. For example, to create the number 2 servos 0,2,3,4, and 6 would be actuated forward while servos 1 and 5 would be actuated back. The mask for the number 2 would be 1,0,1,1,1,0,1.

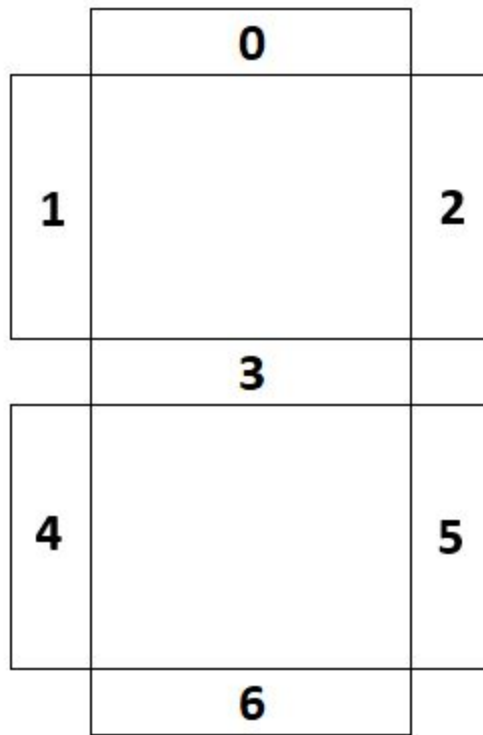

Figure 8: Standard Digit Segment Numbering

Prototype 2b

Overview

Due to potentially poor resolution, as illustrated in prototype 2a, and the consideration to utilize the resources most efficiently, the team proposed a parallel track of design. This design no longer employed magnets to gather ball bearings into a certain shape; rather, seven precut holes would house the ball bearings. The actuation of motors on seven rectangular acrylic inserts controlled the capability to fill the holes. Hence, different combinations of segment holes would collect bearings in the according digit shape. The control mechanism and actuation components remained roughly the same, yet many other aspects were unique to this iteration.

Actuation

The actuation system for Prototype 2b remained essentially the same as for Prototype 2a, except acrylic inserts were positioned in place of magnets. With this system, when the servo motors actuated forward, the acrylic inserts were flush with the front face of the clock.

Display

The display system for Prototype 2b was a significant change from earlier prototypes. In order to solve issues with ball bearing clustering around the magnets, the magnets were discarded, and the dropping system was removed as well. This design featured an acrylic front face with 7 cutouts for the locations of each of the digit segments. As mentioned previously, the inserts for these segments were mounted to the holders on the servo motors, and would fill in the front face when a digit segment was not to be visible. When a segment was intended to be visible, the inserts would be pulled back just far enough to fit a single layer of ball bearings. The dispensing method for this design included a trough attached to a clear face that was coincident

with the front face of the clock, as shown in Figures 9 and 10. With some acrylic inserts pulled back, as the cover was raised, ball bearings would fall from the trough into the spaces for each of the digit segments, and would fill in the shape creating a number. Since the inserts were flush when in their forward position, no ball bearings would be able to fill those spaces, so the final shape would be that of the desired digit.

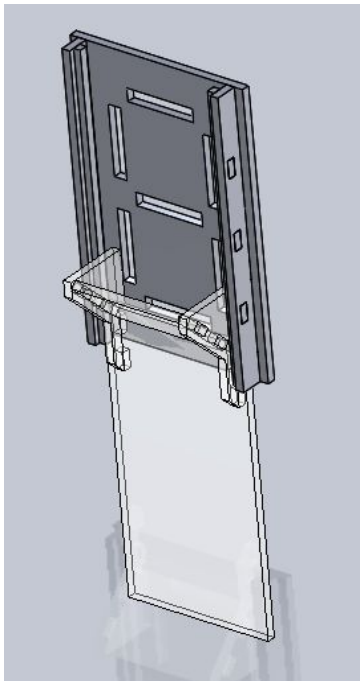

Figure 9: Lowered cover position

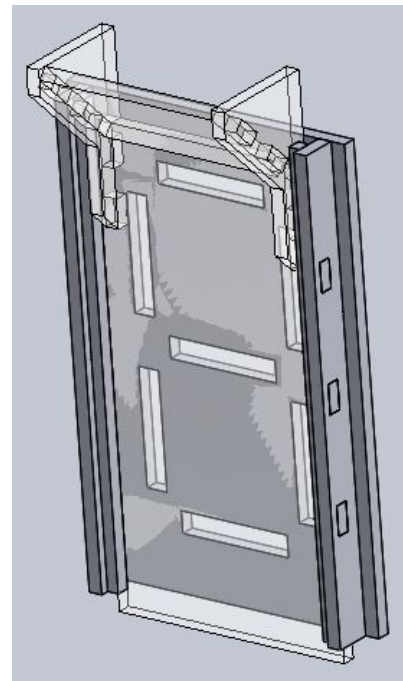

Figure 10: Raised cover position

Additionally, this design included a rack and pinion powered by a DC brush motor as shown in Figure 11 in order to raise and lower the cover.

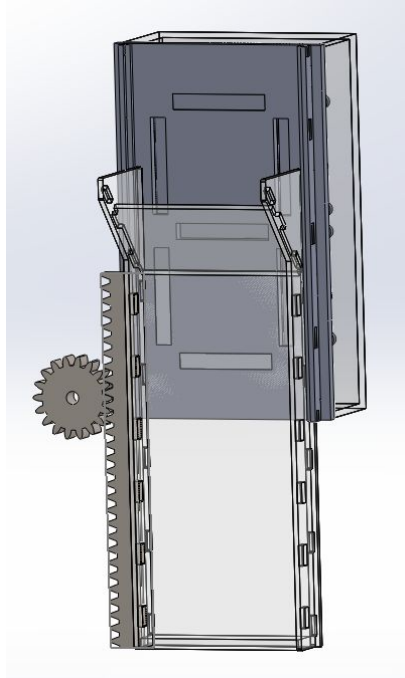

Figure 11: Prototype 2b with rack and pinion and full actuating system mounted

Electronics

The majority of the electronics system for this prototype remained the same as in Prototype 2a, since the mechanisms of the actuating system were identical. The additions made to the electronics centered around the rack and pinion, which was powered by a DC brush motor. This motor was connected to pins on the Parallax microcontroller and powered by pulse width modulation (PWM) so that the speed of the cover could be controlled as it moved up and down the clock face. Additionally, this design required the motor to be able to spin in both directions, so an H-bridge was added to the system in order to achieve this outcome. Lastly, in order to control the extent to which the cover traveled, limit switches were added to the system, so that the motor could be stopped once the cover reached the topmost or bottommost points on the clock face.

Prototype 3

Overview

Prototype 3 fine-tuned the actuating system. Like Prototype 1, it included only one magnet segment of one digit.

Actuation

The tolerancing between the rails and magnet holder was improved to allow for the magnet holder to move more smoothly. In addition, a new 3D printed motor mount was designed to secure the motor more steadily. The rails were connected to the acrylic backplate with an acrylic ring and a screw allowing for easy removal of the rail in the event of failure. This prototype is shown below in Figure 12.

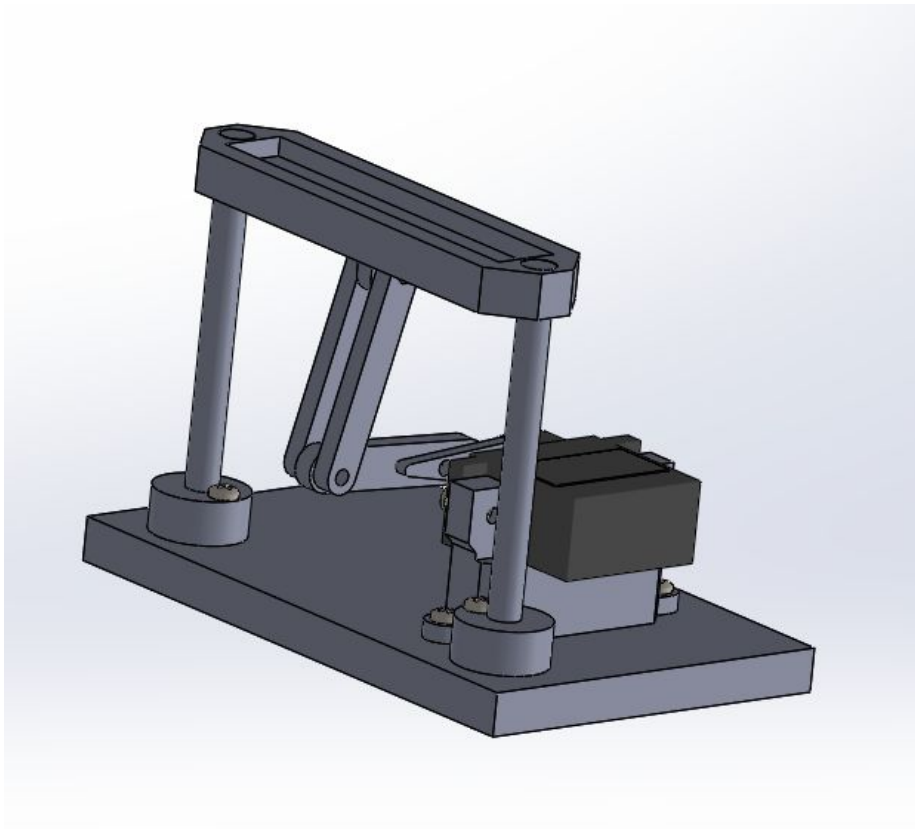

Figure 12: Prototype 3 design

Prototype 4

Overview

Testing in Prototype 2a revealed that since the dispensing mechanism was mounted on top of the digit box, gravity would add excessive potential energy to the ball bearings during their descent to the desired magnet locations. As a result, the magnetic force was not strong enough to catch the ball bearings with high velocity, and the group designed a more adequate dropping mechanism to address this problem. Meanwhile, the actuating system and the digit box design both incorporated minor changes to adjust to the new dropping mechanism.

Actuation

The adjustments made to the actuation system on Prototype 4 were minimal, since the primary goal was to fix issues with the ball bearing dispensing system. The major change at this point came with the size of the housing for the clock digit, which had to increase in size in order to provide sufficient vertical space for the walking wheel to be hidden completely while a digit was being displayed.

Display

To address the resolution problem of the ball bearings clumping against the magnets when dispensed from above, the group modified the revolving-drum design. Now, the rotating drum would roll up and down the clock face. The reservoir and “walking wheel” would now ascend and descend the wall such that ball bearings would be positioned against the wall at the tangential point of contact between the wall and drum. A shell surrounding the drum would ensure that the ball bearings would only release at this point of tangency, as shown in Figure 13.



Figure 13: Spinning a preliminary model of the reservoir-drum assembly

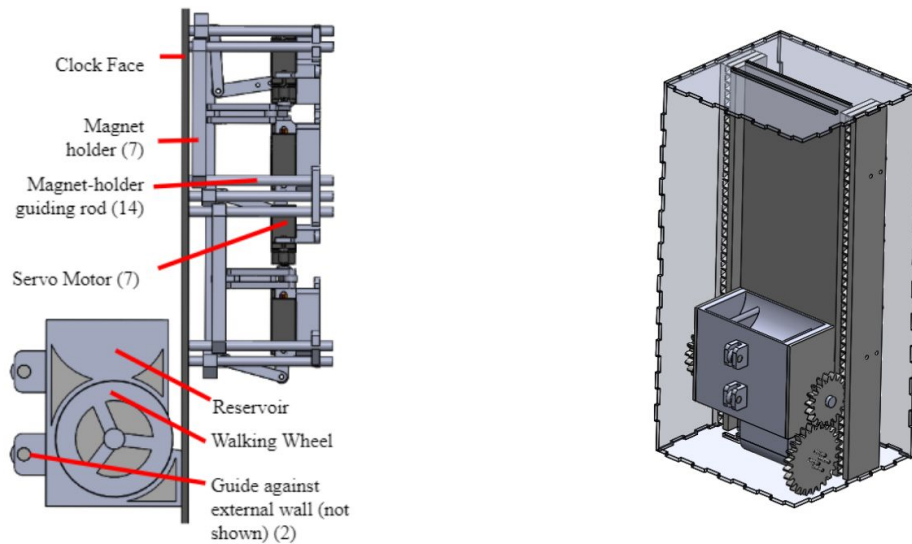

Figure 14: Assembly of reservoir and revolving drum

A brush motor, mounted to the bottom of the assembly, would drive a pinion. The pinion would transmit power to a gear that would both climb up a vertical rack along the side of the clock face and rotate the drum. Two rotational bearings, shown on the left diagram of Figure 14, would constrain the assembly against the clock face.

Ideally, this prototype would position bearings in horizontal rows along the clock face, thereby overcoming previous issues involving resolution. While the time would display on the clock face, the reservoir-drum assembly would wait below the wall. Then, after the minute

would expire, the actuated magnets would disengage, and all ball bearings would fall into the reservoir. The bearings would feed into the drum as it would “walk” up the wall much like the process of loading a revolver, and the drum would dispense the ball bearings during the following descent.

Supplying an adequate amount of torque to lift the assembly and rotate the drum under the weight of ABS plastic and ball bearings proved to be a pertinent issue for this prototype. Long-term functional reliability would be in jeopardy if the motor were to struggle against the weight and friction of the assembly.

Electronics

The majority of the electronics for driving the actuating system remained the same as in Prototypes 2a and 3, since no changes were made to any mechanisms in the actuating system. However, as with Prototype 2b, this design required the addition of a DC brush motor to drive the pinion, and thus the walking wheel, up the clock face. This motor was connected to pins on the Parallax microcontroller and controlled with PWM so that the speed of the walking wheel could be controlled as it moved up and down the clock face. Additionally, this design required the motor to be able to spin in both directions, so an H-bridge was added to the system in order to achieve this outcome. In order to control the extent to which the wheel traveled, limit switches was added to the top and bottom of the clock face. When the switches were hit, the microcontroller would have the motor switch directions or simply stop moving. The circuit used for this prototype is shown below in Figure 15.

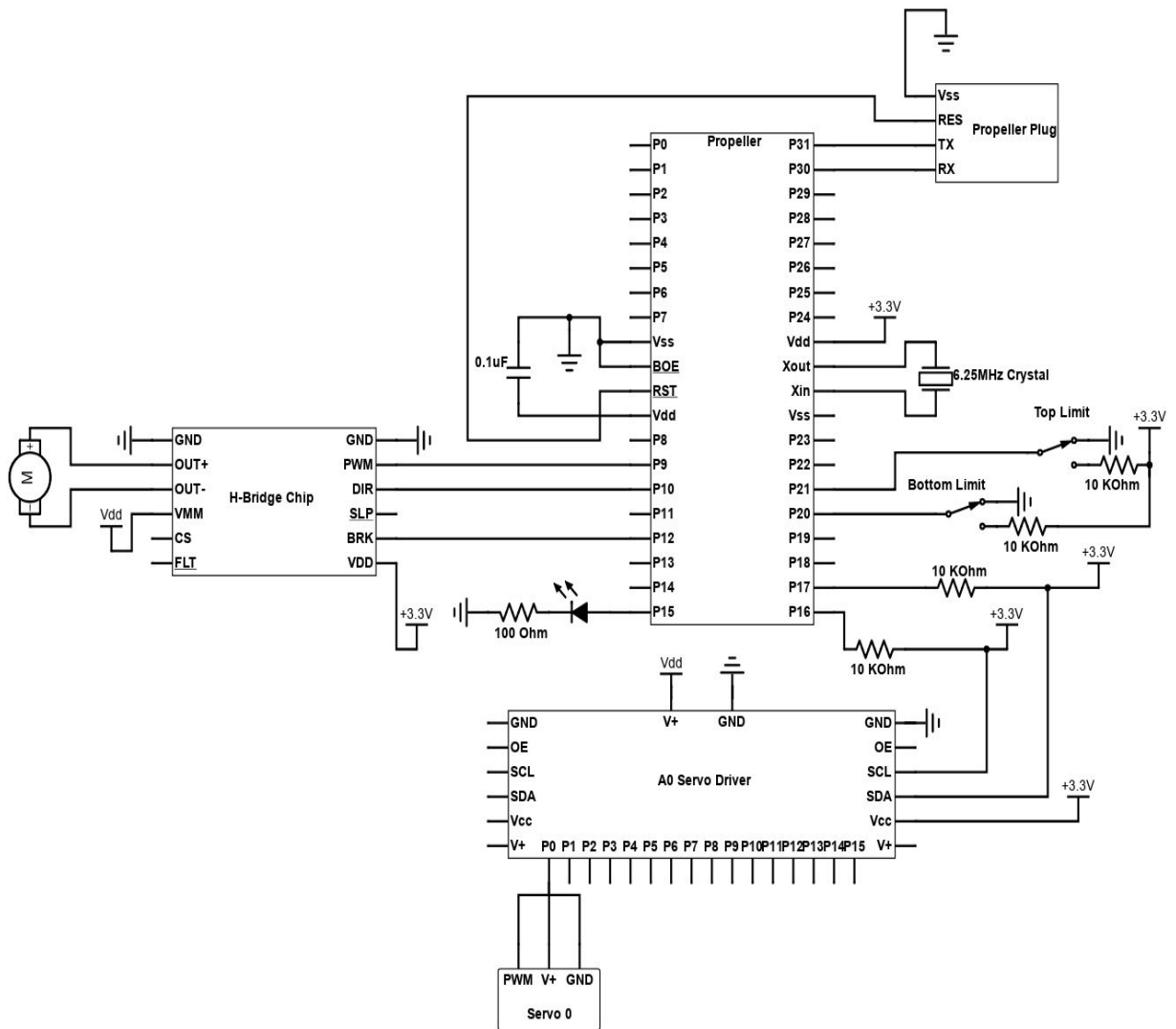

Figure 15: Prototype 4 Circuit Diagram

Prototype 5

Overview

Components of Prototype 4 were fine-tuned. The interface between the drum and the reservoir went through heavy analysis and redesigns until friction and ball-bearing interference were minimized. A worm gear replaced the motor-driven pinion in order to optimize power transmission. The quadrature encoder on the worm gear's motor could then sense when the motor struggled and could trigger a stall-avoidance program.

Actuation

Once again, the actuation system remained mostly unchanged at this point, since the major design changes came with the addition of the worm gear and modifications to the designs of the drum and reservoir.

Display

This design iteration involved replacing a pinion with a worm gear. The change addressed concern regarding a sufficient and reliable amount of torque because a worm gear offered greater mechanical advantage in transmitting power from the motor to the driven gear, which still rotated the drum and climbed the vertical rack, as shown in Figure 16.

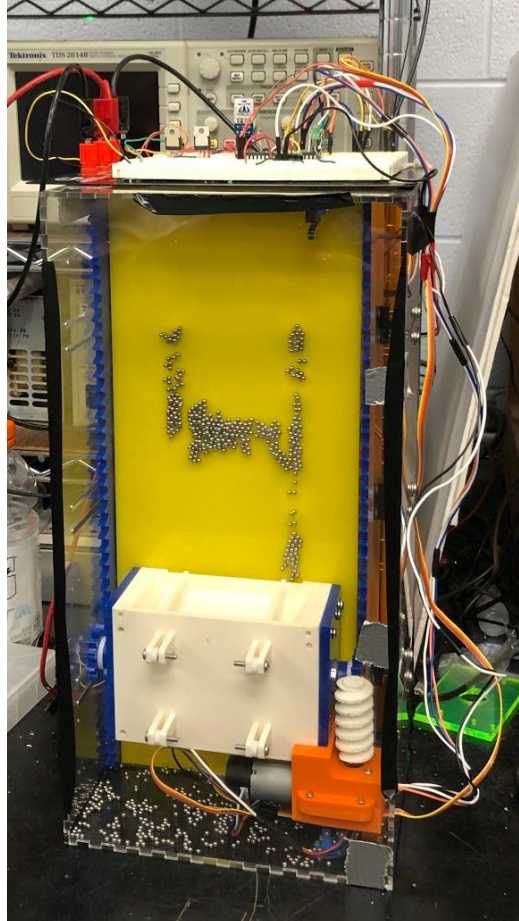

Figure 16: Reservoir-drum assembly with worm gear

Meanwhile, rapid sub-prototyping began to optimize the interface between the reservoir and the drum. “Slices” of the assembly, cut from acrylic, offered a simple way to experiment, as shown in Figure 17. Interference between the ball bearings and the lip of the drum’s shell at this interface motivated the undertaking, and iteration continued until the drum could rotate with minimal resistance.

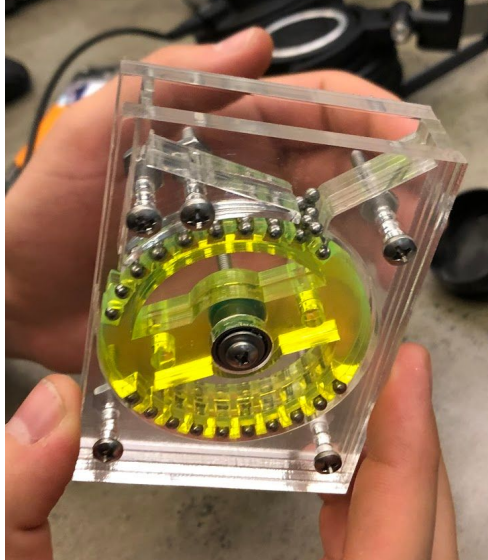

Figure 17: Iteration of reservoir-drum slice

As shown, two additional bearings, which rolled against a transparent front panel, constrained the reservoir-drum assembly against the clock face. Initial results were relatively successful; ball bearings would position into relatively consistent digit arrangements. However, the bearing interference at the interface of the reservoir and drum persisted, which eventually led to the failure of the motor.

Electronics

The only addition from Prototype 4 was the use of the quadrature encoder on the DC brush motor. Since the bearings caused the wheel to bind and the motor to stall, the quadrature encoder was utilized to offer feedback when the motor stalled. This allowed the microcontroller to reverse the motor when it stalled, giving it the opportunity to dislodge the ball bearings and work its way up the clock face. This method worked fairly well, but since the worm gear would

slip on the driving gear, the motor would not fully stall and therefore not reverse direction. This caused the wheel to stay in the same spot and continue slipping indefinitely.

Prototype 6a

Overview

In Prototype 5, the slipping of the worm gear against the rack caused not only energy inefficiency, but also gradual damage to the worm-gear motor. The ball bearings inefficiently recollected in the reservoir after the magnet system disengaged, and the digits displayed by the ball bearings had inconsistent and low resolution. Hence, the group began to find another medium to render the digit display. The group explored a ferrofluid tank as a replacement for the ball-bearing wall.

Actuation

Part of the rationale for switching to ferrofluid was that the actuating system was already working as desired, and the ferrofluid could be integrated without adjusting the actuating system. In this iteration, ferrofluid tanks were built from acrylic to fit the size of the actuating system, so most of the actuation remained the same. One major change was made in order to reset the ferrofluid to the top of the tank when a digit was being changed. Since the system used gravity to help the ferrofluid flow past the magnets and make the digit shape, it was crucial that the ferrofluid move back to the top of the tank in some way. Consideration was given to a system that would rotate the entire digit or entire clock by 180 degrees, but this required extra infrastructure for the clock. Instead, this prototype utilized a design that would raise the ferrofluid by actuating the magnets from the bottom to top. In order to make this design functional, the gaps between the magnets needed to be very small so that ferrofluid would not

lose attraction and fall back down between magnets. The magnet holders were redesigned to bring the vertical magnets on the side of the design closer to the center. This adjustment allowed for the ferrofluid to reset between each digit change without adding any additional infrastructure to the project.

Display

Based on the difficulties with the walking wheel design and the ball bearings in general, the display for Prototype 6a took a different route by using ferrofluid to interact with the magnets and display the digits. Since some of the bunching issues stemmed from the fact that the ball bearings were rather large, the team assumed that ferrofluid would mitigate these problems since each iron particle is very small. In the initial version of this prototype, acrylic tanks were constructed with a ¼-inch clear front face, a ¼-inch frame, and a ⅛-inch opaque back face. The dimensions of the tank were made to fit the outline of the actuation system from Prototype 5. Additionally, each tank had a 6-32 tapped hole in the side of the frame so that the tank could be filled with the suspension solution and the ferrofluid, and then could be sealed with a bolt. Initially, the fluid in the tank was a mixture of 70% isopropyl alcohol and ferrofluid. This mixture was effective at first, but after the fluid sat overnight, the ferrofluid coagulated, as shown in Figure 18, and it became immobile even in the presence of a magnet.



Figure 18: The coagulated ferrofluid inside of the acrylic tank

Based on research about ferrofluid, both the acrylic tank and the isopropyl alcohol were factors leading to this issue. In efforts to fix this problem, a number of different suspension solutions were tested, including a higher percentage alcohol and various concentrations of saltwater solutions. Additionally, most research pointed toward a glass casing as the ideal container for the ferrofluid mixture, so premade glass bottles and tanks were tested. Unfortunately, due to time constraints, the optimal solution was not found, and none of the tested ferrofluid solutions or containers performed as desired.

Electronics

The primary change to the electronics system involved the removal of the DC brush motor from Prototype 5 and the addition of a the DS3234 real time clock chip. All of the electronics used in the actuating system remained the same, but a program was added to actuate the magnets in sequence from bottom to top so the ferrofluid could be raised to the top of the tank before the next digit was actuated. The clock chip uses Serial Peripheral Interface (SPI) to communicate with the microcontroller. This chip includes a temperature-compensated crystal oscillator to keep extremely accurate time. This breakout board also includes a back-up battery, ensuring the chip's accuracy even when temporarily disconnected from external power.

Prototype 6b

Overview

The concept of ferrofluid was promising, but the group continued to experiment with ball bearings. Rather than a reservoir-drum assembly, the ball bearings would fall and collect in a horizontal figure-eight-shaped reservoir, as shown in Figure 19. An additional actuating motor would rotate the originally vertical clock box by 90 degrees and let the magnets catch the ball bearings. Then, by rotating the clock box back upwards, the desired digit would be presented to the audience.

Actuation

The actuation assembly was completely preserved from Prototype 5.

Display

To avoid the complexities of dispensing ball bearings through the drum, the use of a stationary reservoir seemed relatively simple. Instead of the climbing of a “walking wheel”, the

clock face and actuation assembly would pivot by 90 degrees from a vertical display position to a horizontal position, stacked above the stationary figure-eight reservoir, as shown in Figure 19. At this point, magnets would cling to the actuated numeric patterns of the clock face, and the clock would then pivot back to its vertical position to display the time. A winch, mounted on the ground, would control the rate of the box's pivoting rotation via a cable fastened to the back of the clock box.

Electronics

While this concept never matured past initial CAD renders before the group committed to the ferrofluid model, electronics would have been identical to Prototype 5 for actuation, and the power of one additional servo motor would have spun a winch to raise and lower the pivoting clock box.

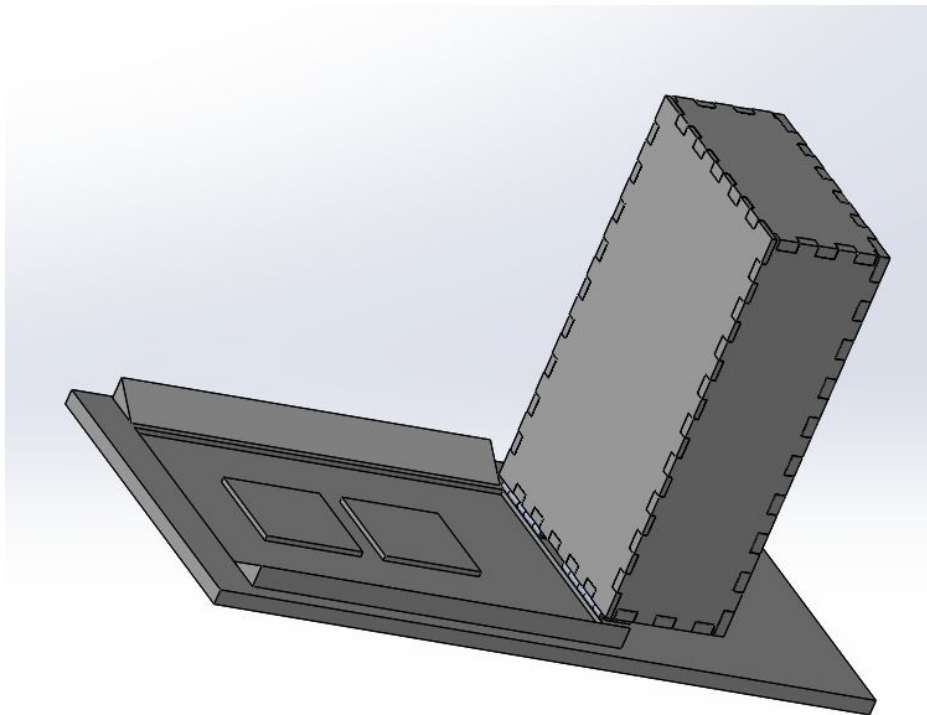

Figure 19: Prototype 6b's "Face-planting" clock concept

Prototype 7

Overview

The ferrofluid design in prototype 6a met all the expectations for the magnet clock, and the ferrofluid prototype was favored over the pivoting-clock-box prototype. Ferrofluid container selection became the main concern. Eventually, the group purchased premade ferrofluid bottles to ensure the longevity of the clock design. Afterwards, final changes to the assembly took place, including optimal motor spacing, clock enclosure, and durable circuitry.

Actuation

The actuation assembly, shown in Figure 20, decreased in size by a factor of two in order to accommodate the size of the prefabricated ferrofluid containers. The dimensions of each magnet were roughly 1 inch by $\frac{1}{4}$ inch, so the overall dimensions of each actuating digit were 3.65 inches by 2.4 inches. The employment of the alternating-servo-motor strategy ensured that the actuating motors would fit within the outline of the smaller clock face. The basic mechanisms--the motor, lever arm, guide rods, and magnet holder, for each magnet were left unchanged.

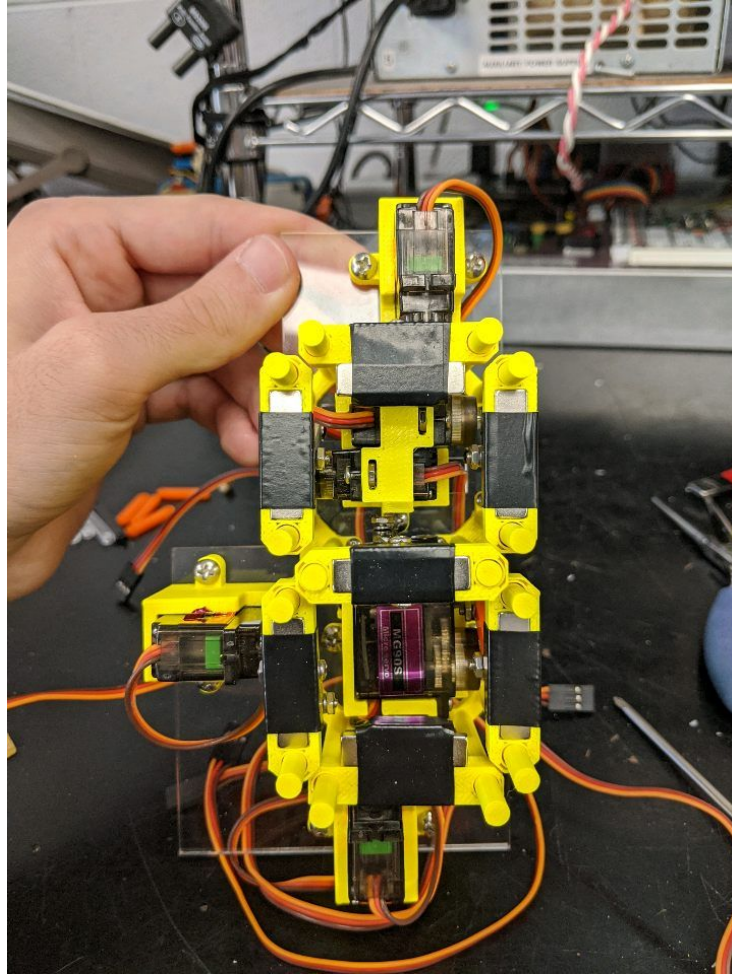

Figure 20: Actuation assembly for scaled down digit

Display

The prefabricated ferrofluid containers caused the outward appearance of the clock to change from a single face to four distinct clock windows--one for the ferrofluid of each digit. Additionally, LED lights were incorporated below each container and behind the semi-transparent acrylic clock colon to augment the aesthetically pleasing appearance of the clock.

Electronics

A Parallax 4x20 Serial LCD screen, along with a five-position joystick and a two-position switch provides an interface for a user to reset and edit the time that the clock would display. The position of the two-position switch corresponds to the display's mode-- "normal" and "set time". When switched to the latter, the LCD display shows the current actuated time, and the five-position switch then allows for adjustment of the time. A return to the "normal" mode blacks-out the LCD display, and the ferrofluid clock then adjusts to the newly set time.

The clock was powered by a 12V, 30A power supply that was housed inside of the box. This power supply went to four separate 5A fuses corresponding to each individual digit. These fuses then went to four individual voltage regulators to decrease the voltage to 6V for the servo motors. This then went to a relay, which is controlled by the microcontroller to turn on each digit's servos when the time changes. This power supply circuit is shown below in Figure 21. There are four of these circuits running in parallel, one corresponding to each digit. Also, a strip of RGB LEDs was added in this prototype. These LEDs utilized a 5V supply which was regulated from the same 12V power supply.

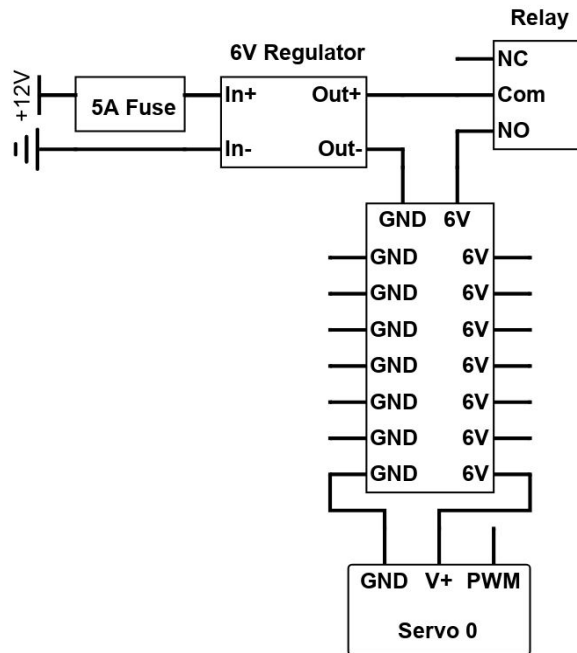

Figure 21: Power supply circuit diagram

A perf board replaced the breadboard utilizing a Parallax Propeller Mini microcontroller. The Propeller Mini microcontroller includes built-in 3.3V and 5V voltage regulators in addition to a built-in EEPROM chip, allowing for a simpler final circuit. The perf board allowed all circuitry to be soldered together in a compact arrangement. This circuit is shown in Figure 22 below.

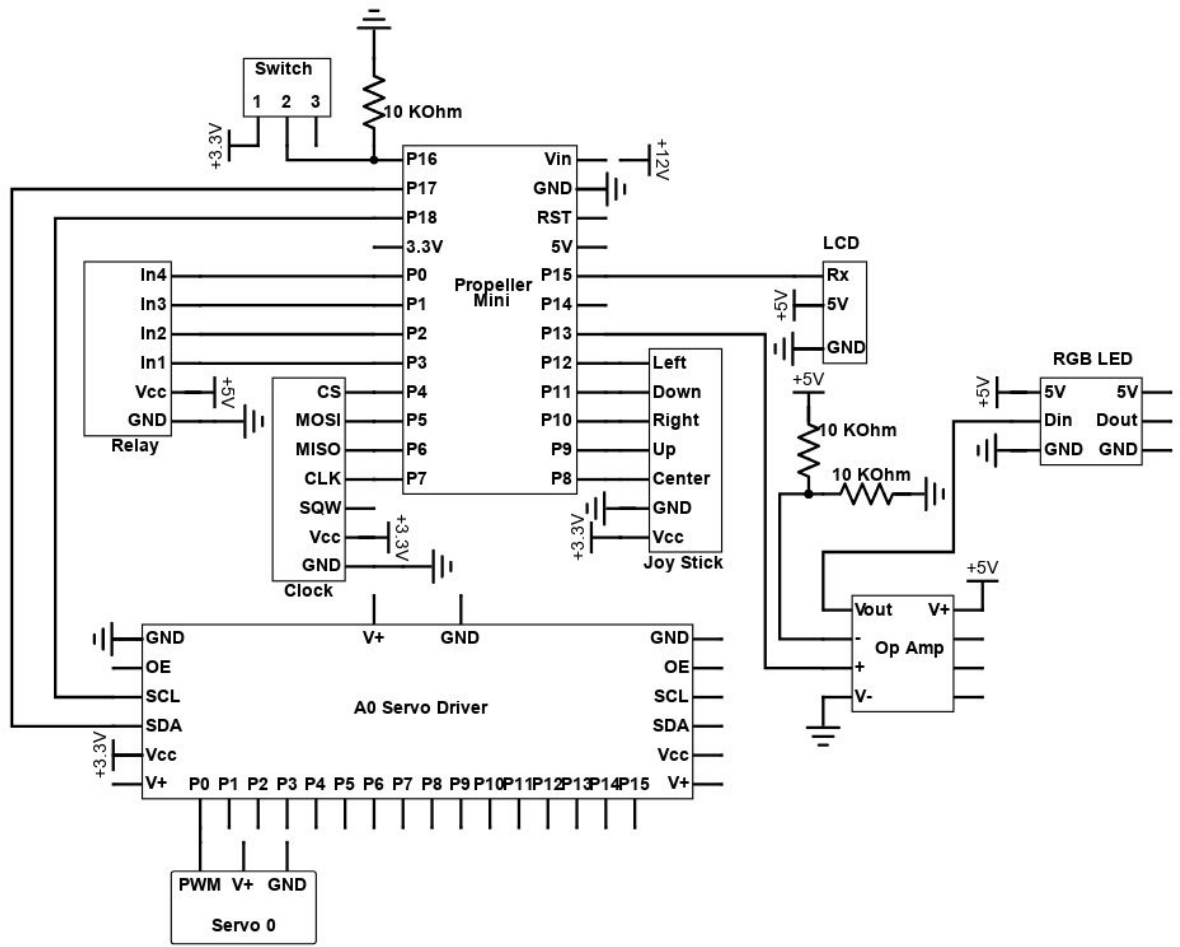

Figure 22: Final perfboard circuit diagram

The finished product of the ferrofluid clock has a dense wood housing. The wood is both durable and aesthetically complementing. A panel to which all four actuation subassemblies are mounted serves as an internal partition, as shown in Figure 23. In front of it, the actuation subassemblies translate magnets back and forth, and behind it lies most of the product's electrical components, including the perf board; relay-fuse panel; 12V, 30A DC power supply; voltage regulators; and I2C chip. Not shown in the figure, the prefabricated ferrofluid containers sit in the rectangular compartments to the front of the foremost white sheets.

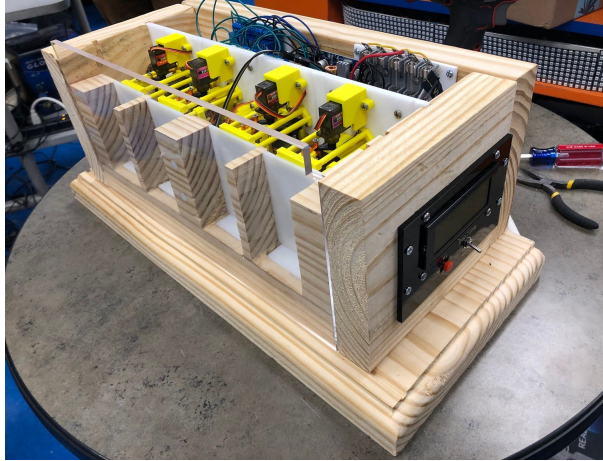

Figure 23: Final clock design and housing, including 4 digits, LCD screen, and electronics

Manufacturing

Due to the complex designs of components and the imperative for accuracy, the advanced part of manufacturing work was undertaken by laser cutters and 3D printers. The group used a Hitachi drill stand to perform minor changes to the parts. Basic manufacturing tools include screws, nuts, file tool, crimping tool and super glue.

PLS6.75 Laser Cutter

For this project, the PLS6.75 laser cutter from Universal Laser Systems was used for all cutting of cast acrylic parts, which were of either 0.25'' or 0.125'' thickness. This accounted for all versions of the motor box, connecting rods for magnet holders, gears and racks, the acrylic container for ferrofluid and certain parts of the final clock enclosure. With a part designed in Solidworks, 2D DXF files were exported to CorelDraw, which would process the file and send to the laser cutter. The usage of the laser cutter allowed efficient prototyping and hence quick iterations. In addition, because of the fact that acrylic pieces are able to be tapped, it expedited the assembly process.

The laser cutter has a kerf, so cutting out acrylic pieces that slot into each other poses a challenge in finding the right fit. A testing device checked the suitable kerf value in order to create press fits. The different kerf values correspond to different polygons.

Figure 24: Laser cutter kerf testing example

When the user would find the correct fit for that particular piece of acrylic, they could adjust the kerf dimension within Solidworks:

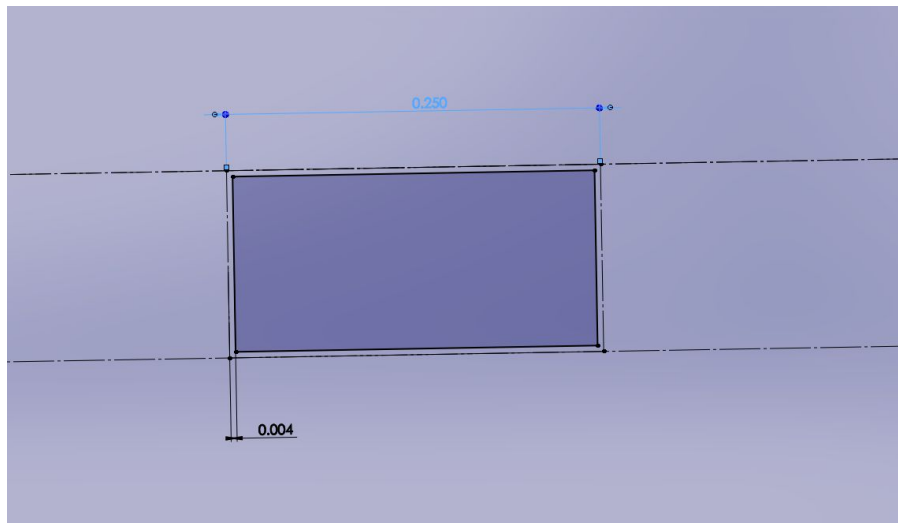

Figure 25: Slot offset example in Solidworks

Dimension uPrint 3D Printer

The Dimension uPrint 3D Printer was also widely used to produce parts of complex 3D shape using ABS plastic. It undertook all the jobs that the laser cutter was unable to perform,

including motor holders, dropping box shield, etc. In Solidworks, an STL file was exported to CatalystEX, which could adjust the dimension and definition of the part. Next, a job order would be sent to the 3D printer. The capability to produce 3D parts facilitated the design significantly. However, there are two major shortcomings: (1) the precise nature of 3D printing comes with cost of long working time, which became the main obstacle for quick design iterations, especially when the mass production started during the final period, and (2) using ABS as printing material makes the finished part vulnerable to external stresses. And it also added difficulty to reworking/reshaping.

Programming

The servo driver used in the project utilized standard I2C protocol. Two pins, one clock and one data line, sent information from the microcontroller to the servo driver. Two of these servo driver boards were used with two digits connected to each of the boards. Each board had a unique address to be used by the microcontroller. Each digit was labeled 0-3 with 0 corresponding to the minutes ones digit and within each digit, each segment was numbered 0-6 as described previously. In order to move a segment of the digit, the microcontroller simply changed the PWM register in the servo driver for that segment. Each segment of each digit had an individually calibrated forward and back value used to move the magnet. These values were stored as an array in the data section of the Spin code. When the servos needed to be moved, the microcontroller would first turn on the relays by changing the output to the relay pins from high to low, using inverted logic, thus connected the common to the normally open. After the servos had been actuated, the Propeller chip would then return those pins to a low state to disconnect the power from the servos.

In order to set the external clock chip, the microcontroller would send bytes of data corresponding to individual registers within the chip to change items such as the minutes or day of the week. The microcontroller would continuously read these registers and compare them to the previous values. When these values changed, it updated a global variable signaling to the servo method that the time has changed and the servos need to move to change the time.

In order for the user to reset the time the clock had an LCD screen with a joystick and two position switch. When the user moved the switch to “Set Time” mode, the LCD screen would turn on displaying the current date and time the clock is set to. The user could then move the cursor left and right with the joystick to move from digit to digit. They could also move the joystick up and down to change the value of that digit. Once the user returned the switch to “Normal” mode, the values they set would be sent to the external clock chip, and the clock would display the new time.

The ferrofluid clock display incorporated 34 individually addressable RGB LEDs. The Propeller chip used assembly code to send data corresponding to each color, red, green, and blue, of each LED. This allows the user to preprogram different colors and patterns to be displayed on the LEDs in the clock.

Future Work

There are a number of ways to continue to improve upon this project going forward. Since the construction of the case for the clock came together quickly toward the end of the project, all of that work was done using manual woodshop tools. Although a good woodworker can achieve a decent level of precision in their cuts, this design could be improved by using a Computer Numerical Control (CNC) router. Using a CNC router, a 2D or 3D design can be

imported directly from a CAD model, and a drill bit cuts out the shape through linear motion in 3 axes. Since the CNC router can move to very precise positions, highly intricate and accurate designs can be created. Improving upon the aesthetics of the current design by creating a new design that can be cut with a CNC machine would be a valuable continuation of the project.

Additionally, the final design of this clock included premade ferrofluid bottles, which required the actuating system to be fit to the size of those bottles, which included a difficult redesign process for the servo motor setup in particular. Based on this design requirement, the final model was significantly smaller than originally intended. If the ferrofluid solution could be properly made in house, and appropriately sized glass tanks could be constructed, the ferrofluid design could be used to make a clock with larger digits that fit to an optimally sized actuating system. Moreover, customized containers would have flat surfaces and desired thickness.

Finally, the design of magnet holders and their interaction with the ferrofluid containers could be polished so that the entire front face of each magnet would push against the back face of each container. Once the contact is improved, all of the ferrofluid within the container would be ideally utilized to render a better resolution.

Conclusion

For this project, a variety of prototypes were tested and iterated. Early prototypes involved refining the actuation system and testing methods of dispensing ball bearings across the clock face. Although the ball bearing system was abandoned towards the end of the semester due to slow progress, the actuating system remained an integral part of the project as the design pivoted to use ferrofluid instead.

Due to difficulties with creating ferrofluid tanks in house, premade ferrofluid bottles were purchased for the final model, and the actuating system was scaled down to fit the bottles. This primarily involved modifications to the layout of the servo motors, as well as the design of the magnet holders themselves. With the development of this final design, four total digits had to be built, a case for the clock was designed and built, and the electronics system was scaled up to include a 12V power supply, LEDs, and custom-made perf boards.

Though a large amount of technical success was achieved during this project, it became clear during the course of the semester that the skills acquired were equally as important as the product itself. Not only were hard skills and knowledge developed, such as CAD modeling, laser cutting, 3D printing, and general use of workshop tools, but skills such as project management, iterative design, and ideation were enhanced as well. Team collaboration has been valued during the whole process, and the group has learned to encounter failures with a positive attitude and understood the essential traits that a qualified engineering design should have. The attributes gained through the project will benefit the future career of every member.