

# **2024 ASCE Concrete Canoe Design Competition - Final Report**

A Technical Report submitted to the Department of Civil and Environmental Engineering

Presented to the Faculty of the School of Engineering and Applied Science  
University of Virginia • Charlottesville, Virginia

In Partial Fulfillment of the Requirements for the Degree  
Bachelor of Science, School of Engineering

**Leon Crawford**

Spring, 2024

Technical Project Team Members

Ethan Ames

Melody Cao

Madison Cannon

Kenneth Reyes

Jason Wong

On my honor as a University Student, I have neither given nor received unauthorized aid on this assignment as defined by the Honor Guidelines for Thesis-Related Assignments

Ryan Henry, Department of Civil and Environmental Engineering

# 1. Introduction

## 1.1 Design Problem Statement

Design and construct a prototype concrete canoe and accompanying product display containing relevant information about the canoe's design, materials chosen, fabrication process, and durability. Deliver a technical presentation to answer questions about the team, design, process, and materials chosen. Deliver a project proposal to summarize technical information. The canoe will be tested in a series of races and evaluated by a panel of judges to demonstrate its quality. Innovative design and fabrication approaches, high-quality aesthetics, and paddling performance are valued more heavily than cost. A realistic project cost estimate should be provided.

## 1.2 Design Objectives

The Concrete Canoe Competition scores concrete canoes based upon their project proposal, technical presentation, prototype concrete canoe, and performance in a variety of races. Project proposals must meet requirements outlined in the 2024 ASCE request for proposals and may earn a maximum of 30 points. The technical presentation allows for team members to stand before a panel of judges and present their research and concrete canoe for a maximum of 25 points. The final product prototype, which is graded on concrete mixture, flotation, aesthetics, durability, and weight, may earn a maximum of 25 points. The final race, a total of five events, may earn a maximum of 20 points. The sum of all events results in a total possible score of 100 points.

The concrete canoe team developed three sub-groups in charge of developing specific aspects of the ship's design: the hull design team, responsible for creating the geometric design of the canoe and performing structural calculations; the mix design team, responsible for material selection and testing; and the construction team, responsible for assembly of the prototype, molds, transportation mechanisms, and all other fabricated devices. Captains for each team were assigned at the beginning of the academic year to develop an overall schedule and ensure that critical deadlines were met.

The hull design team began by developing cross-sectional curve equations, researching and testing a variety of designs before settling on the final configuration. Research included the study of the properties of various hull shapes used in commercial canoe designs, as well as qualitative analysis of how canoe shapes impact stability, speed, maneuverability, tracking, and other hydrodynamic properties. The construction team worked closely with the hull team during this stage, fabricating 3D-printed scale models that were used in flume testing. Hull used these tests to observe the behavior of the canoes in water, and settle on a final design. Construction created a full-scale mold from the final curve equations. A variety of mold types were considered before settling on a female mold based on factors related to mix design and hull reproducibility.

Once the final curve equations were selected, structural calculations were performed by the hull design team. They performed a longitudinal analysis, a punching shear analysis, and

created a failure envelope. They also confirmed the buoyant force produced by the boat. This could only be done once the mix design team had established an approximate value for the unit weight of the final concrete mix and determined that two-foot-long air pockets would be necessary at either end of the canoe to ensure buoyancy.

The Mix team moved forward with the ultimate goal of creating a mix with the lowest possible environmental footprint while maintaining the structural integrity of the concrete. Materials were therefore carefully selected and systematically tested to determine the optimal combination of a mix with a low carbon footprint and with satisfactory strength and density. Materials were ordered, mix designs were created and prepared, and testing began in October.

Through the use of selective material acquisition, rigorous design and testing procedures, and thorough hull design research, our team worked to ensure the success of our concrete canoe prototype, the *Row-Tunda*, at the 2024 ASCE Virginias Symposium. Last year's success at the 2023 ASCE Virginias Symposium gave us the opportunity to educate a second team, UVA's Exhibition Team. Our senior members provided mentorship and advice on major hull, mix, and construction testing methods. Additionally, construction and mix of both teams collaborated during combined meetings to share manpower and ideas. General body meetings were also facilitated to update all members of the progress done by each team and discuss solutions to any issues that may have arisen.

### **1.3 Background**

The Concrete Canoe Competition is an annual worldwide competition hosted by The American Society of Civil Engineers (ASCE). College and high school students have been racing each other in concrete vessels since the early 1970s. Universities and high schools all around the world compete in this competition at a regional level for a chance to move on to the national competition. For 2024, the national competition will be hosted in Salt Lake City, Utah by Brigham Young University.

Creation of the concrete canoe is broadly divided into hull, concrete mix, and construction. Hull strives to create a hydrodynamic design to create an effective canoe which will perform well both under technical inspection alongside in performance during the series of symposium races. This results in a design that defines the length, width, and curvature of the hull of the canoe. Air pockets are constructed on the gunwale to provide buoyancy in the case of canoe submersion.

Concrete mix design is largely composed of cementitious materials and aggregates. Aggregates are coarse to medium grained particles which provide strength and body to concrete. Cementitious materials are composed of fine grain particulates which, when mixed with water, work as a binding agent for aggregates. The density, strength, and effectiveness of each material within the concrete mix plays an integral part in the canoe's overall strength, weight, and durability. The Request for Proposal (RFP) defines strict rules on mix design elements, such as the ASTM standards which materials must meet, proportion of material or element per volume of canoe, and limitations upon reinforcement. Concrete is typically a stronger material under

compression than tension. To combat the flexural issues a canoe might face in the water, reinforcement such as mesh is permitted to be placed within the canoe.

Construction works closely with Hull and Mix to create a mold which fits the dimensions of the boat design specified by the Hull team. The needs of the specific mold are then communicated to the Mix Team to create a final design which fits the strength, density, and workability required by the mold.

## 2. Design

### 2.1 Objectives

'Hoos on the Move fully addressed the client's ultimate needs by targeting the Committee on Concrete Canoe Competitions' (C4) objectives. The final product takes a sustainable approach that prioritizes quality, minimizes waste, and optimizes production. Our team developed a high-strength mix design that meshes well with a stable and hydrodynamic geometric design. Our construction method supports reproducibility for each unit. With the use of our modular female mold, canoes can be produced uniformly for several hundred units and sent out to end users with ease. The final product consists of a shallow-vee hull design with piecewise cross-sectional equations, with the six inches closest to the canoe's neutral axis being an exponential function and the outer eight inches being a fifth-degree polynomial function.

The canoe is 16 feet in length. The width varies but is symmetrical. The middle section has the largest interior width of 28 inches and exterior width of 29.5 inches, due to the thickness of the concrete walls. At the ends of the seatable area, the width is 22 inches in the interior. The canoe's design from a plan view follows an elliptical shape. The canoe ends each have 2 feet of air pockets to help with buoyancy. To pour the canoe, a reusable female mold concept was used. A box frame with 37 rib-like cross sections in the center lined with plywood was used to cast the shape of the canoe.

The concrete mix was then applied on the inside of the mold and smoothed used trowels. The team's final mix design achieved sustainable, light-weight, and high-strength qualities. It consisted of Type IL Portland Limestone Cement, Type S Hydrated Lime, Grade 120 Granulated Blast Furnace Slag, Poraver (2-4mm), Poraver (0.5-1mm), Arcosa Riverlite Alabama Expanded Clay, EIFS Stucco Mesh, and PVA15 Fibers. The final mix design was tested, yielding an average 7-day compressive strength of roughly 2,690 psi and a density of 73 lb/ft<sup>3</sup>. Per ASTM-C78, beams were tested and had a flexural strength at the outermost fiber of about 353 psi after 10 days.

Paddling performance was optimized through rigorous testing, ensuring the canoe's reliability in challenging scenarios such as 180-degree hairpin turns and a 200-meter slalom course. Realistic cost estimates were provided, acknowledging the value of innovation over the lowest cost while presenting a transparent breakdown for informed decision-making. This holistic strategy aimed to exceed the Committee's expectations, emphasizing transparency and quality assurance. Aesthetic considerations emphasize a historical and locally inspired theme that celebrates the harmony of Virginia's myriad aspects of beauty. The Rotunda serves as the

centerpiece of the University of Virginia and is a “temple to knowledge, reason, and the illimitable freedom of the human mind.” The *Row-Tunda* serves as a symbol of passed-down cumulative knowledge, advocating for sustainability, and the rich culture of UVA and Charlottesville.

### **2.1.1 Hull**

The hull design implemented by last year’s canoe team consisted of a wide, flat-bottomed canoe, with a cross section defined by a simple fifth-degree polynomial curve. This design provided much needed buoyancy and stability, both of which were desired as a result of the relatively heavy concrete mix used by the team in that model. However, this design offered little in terms of straight-line speed, tracking, and maneuverability. The goal of this year’s hull team was to design a canoe which improved in these criteria, while maintaining the positive attributes of last year’s design. A number of commercial canoe designs were researched and considered for use in this project, with speed, maneuverability, tracking, and stability being considered determining factors in design selection.

Two designs were considered as extremes for the cross-sectional curves in this year’s canoe: a vee-shaped canoe, with steep sloping sides, and a flat-bottomed hull similar to last year. The vee-shape featured poor stability, but very good straight-line speed and tracking, whereas the flat-bottomed canoe’s greatest strength was its high stability. Based on the advantages of these two designs, the team considered implementing a shallow-vee design, which would feature a wide hull shape to provide it with stability, and a hydrodynamic shape which would improve its performance in a race. The team decided to design two ships, one a shallow-vee design and the other a flat-bottomed canoe conceived as an improvement on last year’s hull structure.

Both designs were rendered in Solidworks, with scale models of each canoe being 3D printed. The models were tested in a flume under various flow conditions, and their behaviors were measured and observed. It was determined by the team that the shallow-vee performed better in all hydrodynamic criteria than the flat-bottomed canoe, with the two boats featuring a negligible difference in stability. The shallow-vee hull design was finalized and sent to the construction team for assembly of the mold cross sections. Structural calculations were performed to determine final properties of the canoe, including its maximum bending moment and shear force under a variety of loading conditions and its buoyancy.

### 2.1.2 Construction

This year the construction team focused on two major goals: utilizing construction management techniques to decrease cost and generating a sustainable reusable mold concept. This being the team's second year participating in the competition we felt a mold that can be built on or modular would be a big help to the organization. To meet these goals the team decided on developing an injection mold with wood being the primary construction material. This being the team's second year of participating in the competition we felt this would be a challenge but important for continuing the program. Our team planned to mitigate risk by developing a construction plan that would allow us to change to a female mold without causing delays in construction. We also planned to further reduce risk by using virtual design software early on to help generate more accurate material cost estimates for our construction.

Our team decided on using a box frame with rib-like cross sections in the center which would be lined with plywood to create the shape of the canoe. In order to meet that goal of a sustainable reusable mold we felt that we needed to generate a design that would allow the canoe to easily be removed from the mold without damaging either. This was achieved by creating a design that has two completely independent sides with three connector components holding the two together which we refer to as the “front plate”, “back plate” and “spine” of the mold. The spine of the female mold was made of two long parallel 2x4 members that were bolted together and could be separated by removing the bolts. The front and back plates are each component of the box frame that keep the walls of the box frame held together at a consistent distance. Each cross section would be split down the center and connect to the walls of the frame and then to the spine, one for each side. Once the conceptual design was complete we moved into generating the detailed design in Autodesk Fusion 360 which allowed the team to create accurate construction documents, plans, and a detailed cost analysis.

Our team consulted both the FAB Lab and ACI 347-04 during material selection and determined that 3/4in plywood, 4x4 wood post, and 1/8in thick plywood would be the best materials for construction of the mold to ensure it would properly support our concrete. Using the design documents our team constructed the exterior of the mold and the individual pre-cut cross sections in preparation for the release of the curve equations from the hull team. After the release of the curve equations the

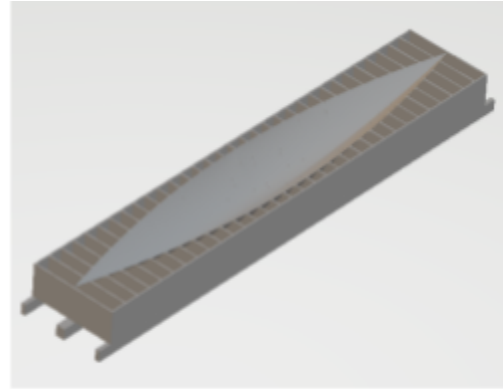

Figure 1. Prototype Mold



Figure 2. Mold Construction



Figure 3. Final Mold

cross sections were completed using band saws and chop saws that were offered in the FAB Lab. After everything was cut, the team was able to install the cross sections and assemble the major structural components of the mold.

It was at this point in the construction process that the decision was made to move from an injection mold to a female mold. This decision was based primarily on the concerns the team had in ensuring our mesh material could be properly placed into the final canoe without shifting while the male mold was being installed. The team's risk management plan went into effect and resulted in zero cost events or changes to the construction schedule. Moving forward with the female mold concept the 1/8in plywood was soaked in water for at a minimum 3 hours and then placed across the structural members and stapled into place to create a continuous smooth surface for the concrete to be placed. The tip of the mold presented a challenge as the 1/8in plywood couldn't shape to the radius at that point and 1/16in plywood was used to complete those sections.



Figure 4. Pour Day

material after the 13th batch of concrete.

Once the reinforcing material was in place the construction and properly worked in by agitating the concrete mix to generate a dilatant effect. Once the material was properly worked in, the team began placing the second layer of concrete mix conducting periodic inspections of the thickness of the second layer. The team completed the second layer of concrete after the 28th batch and a large portion of the construction effort went into ensuring the canoe had a consistent thickness throughout. Once the thickness was confirmed the team shifted its focus to ensuring the top most layer of the canoe had a completely smooth consistent finish. Once the final inspection was completed the team sprayed the canoes down with water and covered it with sheets of soak burlap and a plastic sheet to maintain the moisture content.

On pour day the construction team began by measuring and cutting the reinforcing material provided by the Mix team. The construction team also constructed a number of makeshift measurement gauges in order to ensure each layer of concrete met the design requirements. The construction team covered the polyethylene liner with a concrete release agent to help in the release of the canoe once cured. The construction team began placing concrete focusing on the center portion of the canoe first and building up from there. The first layer of concrete was placed by hand and then smoothed into the desired thickness using trowels. The leadership of the construction team conducted periodic inspections of the concrete thickness and made the decision to place the reinforcing



Figure 5. Final Canoe

During the final stages of mold construction, the hull team reported that the canoe would need two-inch air pockets on each side. Foam was chosen as the material for the air pockets but, due to imperfect bending of the plywood some innovation was required to figure out the new interior curves at the ends of the canoes. The team landed on a solution that consisted of measuring the interior curves of the final canoe with pipe cleaners. When placed along the interior of the canoe, the pipe-cleaners hold their shape, allowing for the exact curves to be recreated on the pieces of foam. One week into the curing process the team placed the measured execution curves traced onto the foam, hot knives were used to cut out the shapes. The pieces of foam were then connected with duct tape and covered in packing tape to prevent water infiltration into the foam. The foam was then installed and encased in this year's concrete mixture with help from the mix team.

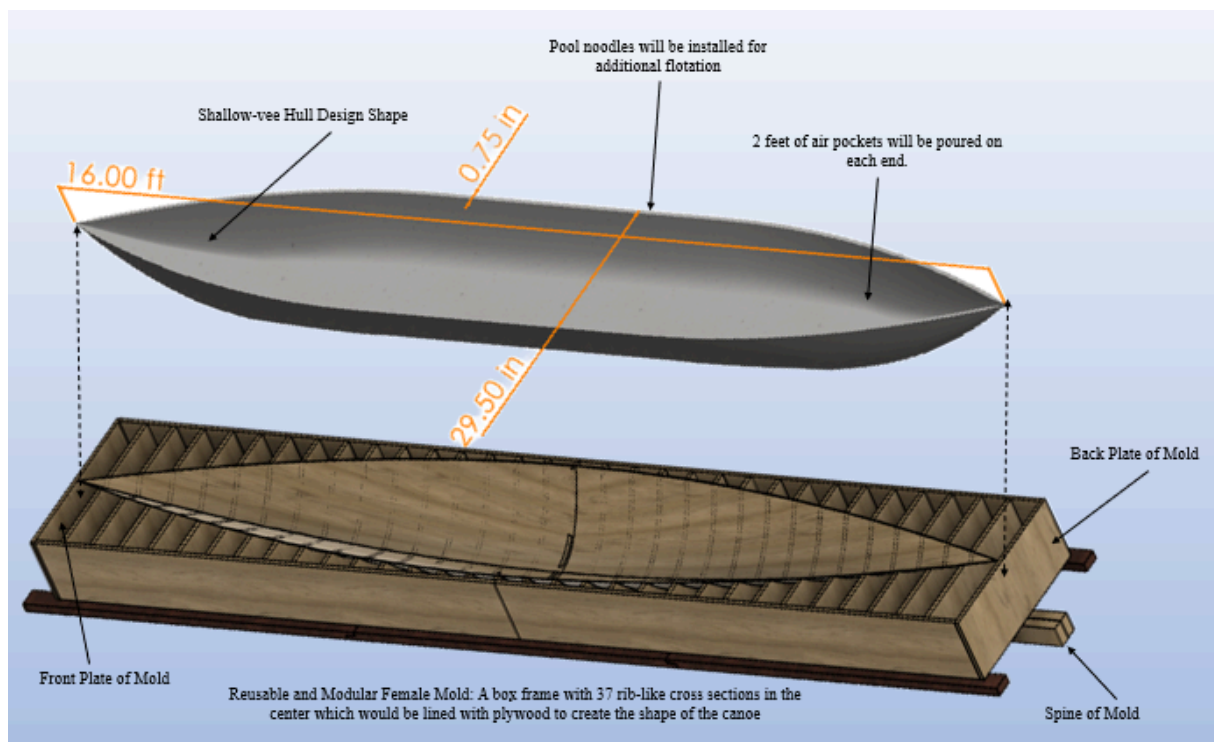

Figure 6. CAD models of the Row-Tunda and the Accompanying Female Mold

### 2.1.3 Mix

For the 2024 competition, the mix design team embarked on a mission to create an innovative concrete mixture that eliminated the need for traditional cement while adhering to the team's standards of durability, sustainability, and weight. Most importantly, all regulations set by the RFP were to be followed.

The journey began with extensive research into alternative cementitious materials, ultimately leading to recognizing Type "S" hydrated lime as a promising substitute for Ordinary Portland Cement (OPC). Derived from limestone, hydrated lime boasts a lower carbon footprint



due to its less intensive kiln firing process and its unique ability to reabsorb the carbon dioxide it releases through a process called carbonation, making it a relatively carbon-neutral material.

Experimentation involved testing various combinations of hydrated lime with pozzolans like ground granulated blast furnace slag (GGBFS) and silica fume. GGBFS, a byproduct of quenched molten iron slag, significantly reduces environmental impact by curbing carbon emissions. GGBFS was selected as the pozzolan due to various strength tests showing greater returns than silica fume. Additionally, both hydrated lime and GGBFS have established track records as reliable supplementary cementitious materials, reducing the reliance on conventional cement.

As iterations of the original mix design were created, adjusted, and tested, the mix design team determined that the hydrated lime and GGBFS alone consistently resulted in lower-than-ideal compressive strength during concrete cylinder testing. Cylinders created without Portland cement were tested with compressive strengths ranging from 770 to 1200 psi.

Due to said concerns about strength, the team decided to incorporate Type IL Portland Limestone Cement (PLC) into our final mix design along with GGBFS and hydrated lime. PLC lowers CO<sub>2</sub> emissions by 8-12% per ton of cement compared to OPC. By replacing clinker with limestone, PLC effectively reduces the greenhouse gas emissions associated with clinker production. This addition enhances the mixture's strength, durability, and workability while still contributing to our overall goal of emission reduction.

As for aggregates, early research was conducted to find sustainable, lightweight aggregates. Earlier designs used Aerolite, an ultra-lightweight granulated foam glass from Aero Aggregates North America. Due to supply discontinuation, the mix team focused on using two grades (0.5-1 mm and 2-4 mm) of Poraver's expanded glass microspheres, which have lightweight properties. Additionally, the mix team integrated Arcosa Riverlite® Alabama expanded clay lightweight aggregate to further bolster the mixture's strength. All materials were purchased within the United States as a prioritized effort toward sustainability.

Compared to the mix used in the prior year's design, this year is significantly more sustainable and less dense. The reinforcement we chose for this year was a non-adhesive Exterior Insulation and Finish System (EIFS) stucco mesh, a strong improvement to the workability of the carbon fiber mesh used the previous year. Comparatively, stucco mesh is a more flexible, lighter, and more easily manipulated material with smaller openings, allowing for greater ease of installation. Polyvinyl alcohol (PVA) fibers were used as another source of reinforcement material to prevent cracks and improve tensile strength.

Table 1. Final Mix Design Properties

<b>MIX DESIGN PROPERTY</b>	
<b>Compressive Strength</b>	2690 psi
<b>Density (fresh concrete, 0 days)</b>	74 lb/ft <sup>3</sup>
<b>Density (hardened concrete, 7 days)</b>	73 lb/ft <sup>3</sup>
<b>Slump, Spread</b>	1.25 in
<b>Air Content</b>	15.0%
<b>Composite Flexural Strength, 10 days</b>	353 psi

Table 2. Final Mix Design Material Composition

<b>Row-Tunda Material Composition</b>
<b>Type IL Portland Limestone Cement</b>
<b>Type S Hydrated Lime</b>
<b>Grade 120 Ground Granulated Blast Furnace Slag</b>
<b>Poraver® (2 - 4 mm)</b>
<b>Poraver® (0.5 - 1 mm)</b>
<b>Arcosa Riverlite® Alabama Expanded Clay</b>
<b>EIFS Stucco Mesh</b>
<b>PVA15 Fibers</b>

## 2.2 Constraints and Engineering Standards

During the design and construction process, the team applied the standards listed in the Request for Proposals (RFP) written by the ASCE Committee on Concrete Canoe Competitions (C4), the group hosting the competition and fielding proposals for a concrete canoe design. Within the RFP, there are specifications and requirements for hull design, mix design, construction, and aesthetics that are enforced through the scoring system. Additionally, certain ASTM standards were referred to during the testing of our materials and concrete mix. All materials used in the concrete mix and reinforcing are allowed and comply with the ASTM standards required by the RFP.

Important constraints and considerations in design of the canoe's hull were outlined in the project's RFP, which guided the team in determining the ship's primary dimensions and volume. ASCE suggested that a four person load case was used for structural calculations, given that this is the greatest number of people expected to be in the canoe at any one time. A weight of 200 lbs was assigned to each of the four paddlers, along with a safety factor of 1.6 for live loads and 1.2 for dead loads. It was critical that the canoe displace enough water to produce a buoyant force greater than the four-person load case, which informed the team's selection of the canoe's depth, length, width, and thickness, as well as the curvature of the boat's hull.

Time restraints were in place due to the date of the ASCE Concrete Canoe Competition and ASCE Virginias Symposium and the requirements put in place. The concrete canoe required a minimum of at least two weeks to cure. As the symposium would take place beginning March 28th, the *Row-Tunda* was required to be completed by mid-March.

Per the RFP, the total weight of cement cannot exceed 50% of the total cementitious material in the mix design. The total aggregate volume must be a minimum of 30% of the total volume of our entire mix. Our tensile reinforcement (Stucco Mesh) is covered in concrete and meets the minimum percent open area ratio of 40%.

Mix testing protocol included the Standard Test Method for Slump of Hydraulic-Cement Concrete (ASTM C143), Standard Practice for Making and Curing Concrete Test Specimens in the Field (ASTM C31) after each mix, and the Standard Test Method for Flexural Strength of Concrete (Using Simple Beam with Third-Point Loading) (ASTM C78).

### **3. Conclusion and Discussion**

To bring the *Row-Tunda* to reality, a concerted team effort was required. Capstone team members led the charge in mix design, hull design, construction, and project management tasks to successfully meet all requirements set in the ASCE Request for Proposal. The mix design team performed extensive testing to finalize a lightweight 73 lb/ft<sup>3</sup> concrete mix with minimal hydraulic cement. This work improved the sustainability and practicality of the canoe compared to last year's product. The hull design team prepared a hydrodynamic geometric design and performed detailed structural calculations to provide more insight on the canoe's physical limits. The expertise and persistence of the construction team brought the design to prototype status with great quality.

This endeavor was not without its challenges. Mix material supplier issues, funding scares, and technical problems came up throughout the life of the project, but weekly Capstone meetings allowed the leaders of the project to create solutions that would keep the project moving. Despite the challenges, a competitive product was created and the UVA team earned a 2nd place overall finish at the 2024 ASCE Virginias Symposium (Appendix E).

To be competitive for a first place finish in the 2025 Symposium, several areas of the program could be improved. Going from little Portland Cement to zero Portland Cement in the mix design, using a more hydrodynamic hull design, and modifying construction techniques to

decrease cost are technical changes to make. Additionally, prioritizing aesthetics by using concrete sealers and stains will be the key to making our product worthy of a first place regional finish. Our team will communicate these goals to the future leaders of the program who will carry out future successes.

**4. Appendix A – Detailed Schedule**

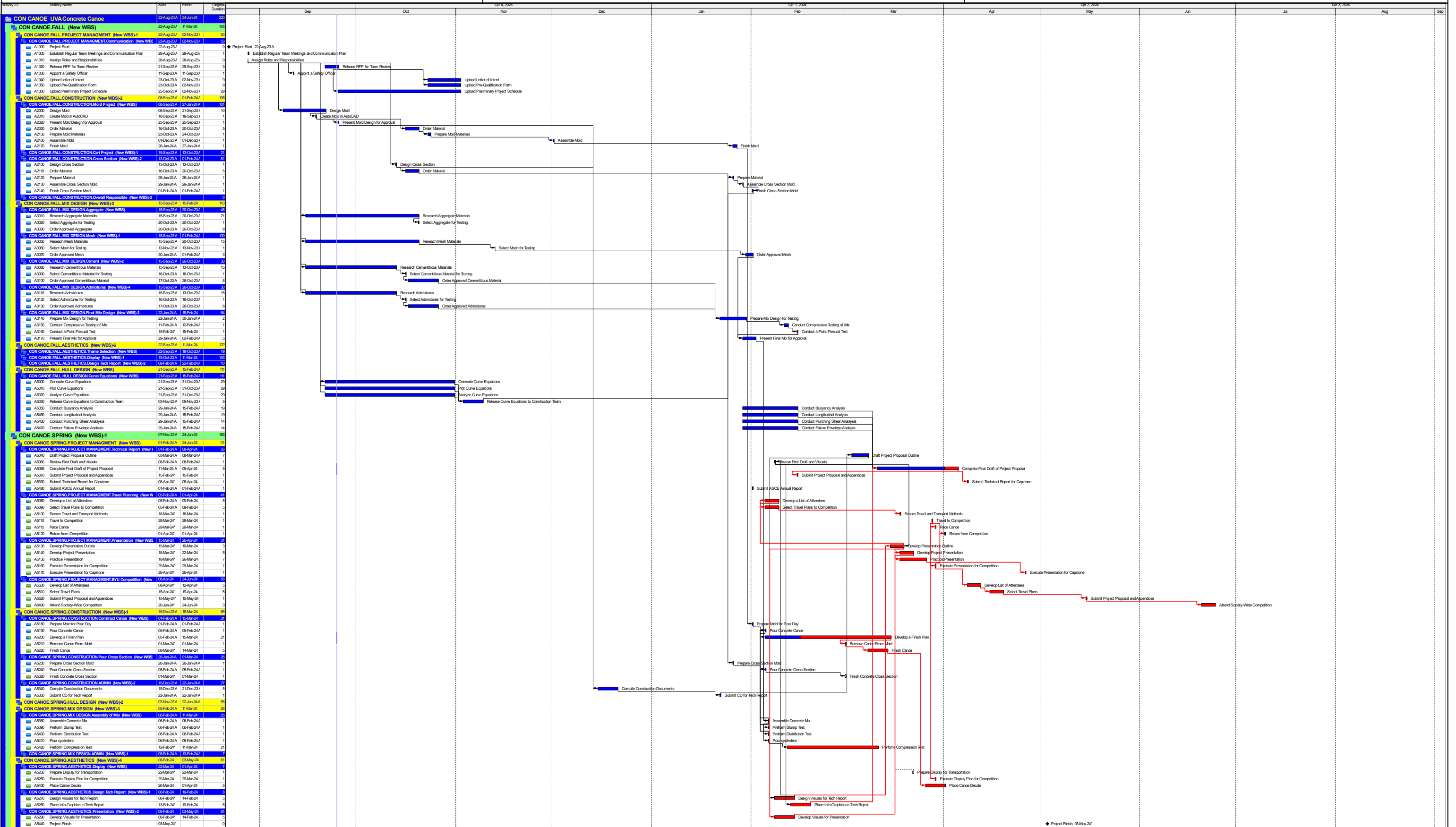

■ Actual Level of Effort    
 ■ Remaining Work    
 ◆ Milestone    
 ◆ Milestone  
■ Actual Work    
■ Critical Remaining Work

## 5. Appendix B – Design Evolution

### Construction:

Below are the conceptual drawings and prototype of the canoe during development. See Design section for further details.

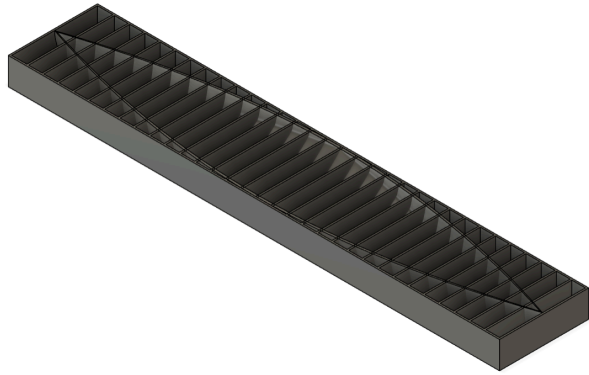

Figure 7. Conceptual Design of Injection Mold

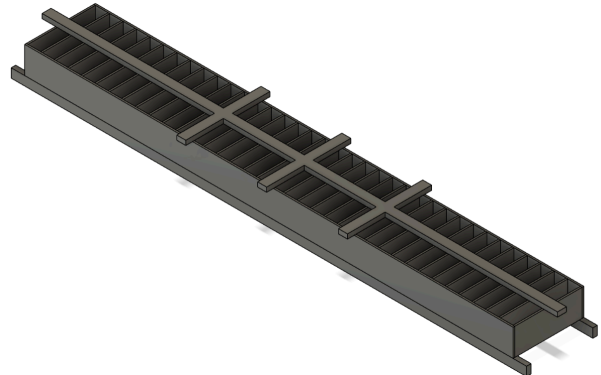

Figure 8. Conceptual Mold Design

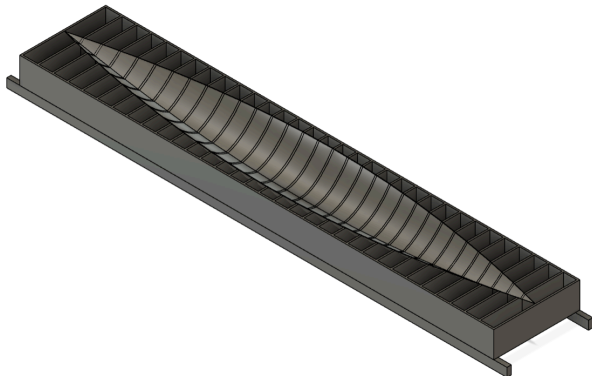

Figure 9. Detailed Design for Female Portion of Injection Mold

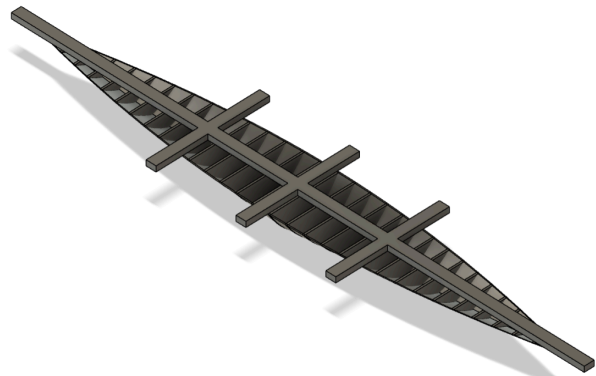

Figure 10. Detailed Design for Male Portion of Injection Mold



Figure 11. Detailed Design for Reusable Female Mold

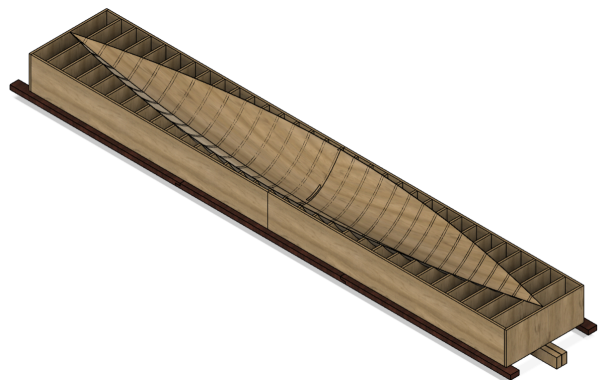

Figure 12. Complete Detailed Design for Reusable Female Mold

## Mix:

Below is the evolution of 28 day compressive strength as the mix design was modified. See Design section for further details.

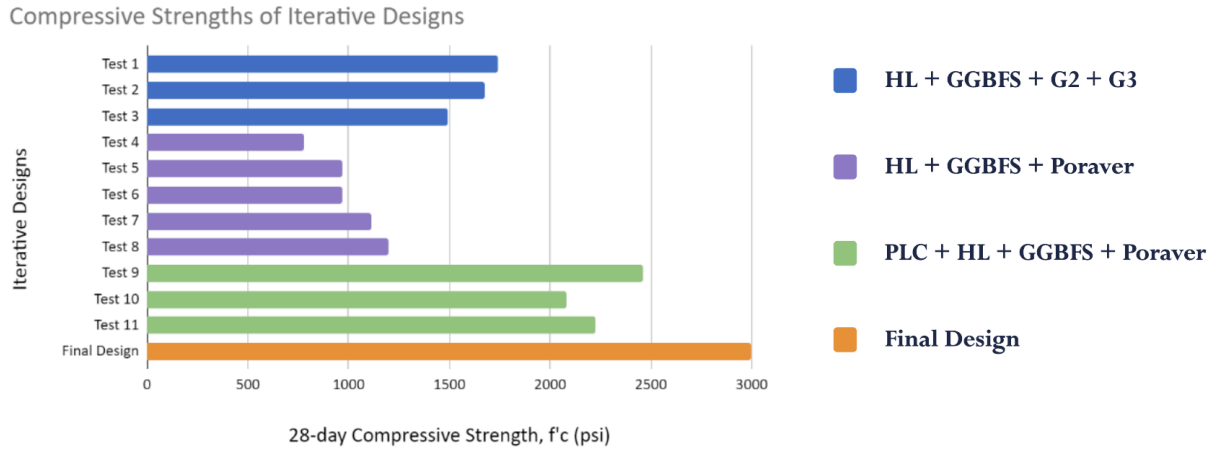

Figure 13. Evolution of Iterative Mix Designs

## Hull:

Below is a graphic depicting the geometric difference in the 2023 and 2024 canoes. See Design section for further details.

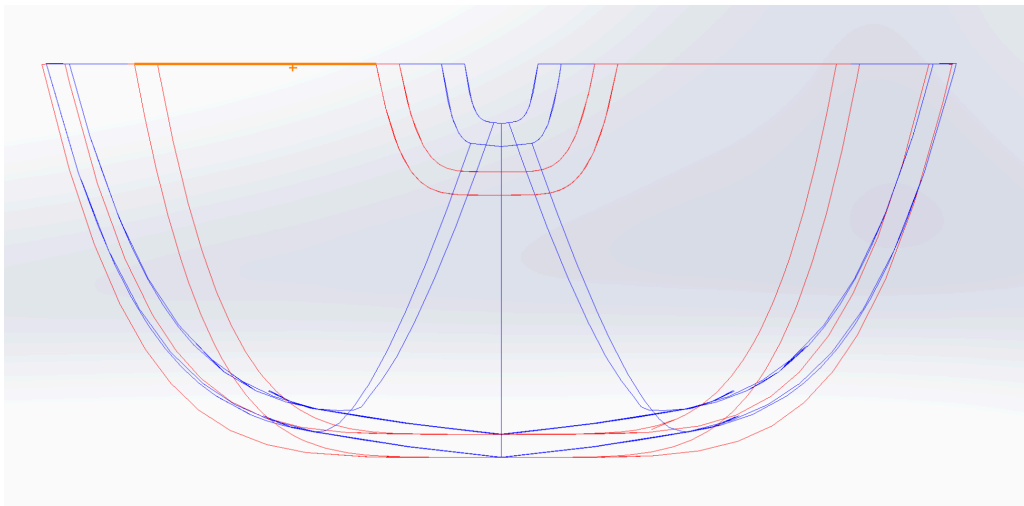

Figure 14. Comparison of Flat-Bottomed Canoe (Red) and Shallow-Vee (Blue)



## **6. Appendix C – Engineering Standards**

### **Standard Test Method for Slump of Hydraulic-Cement Concrete (ASTM C143)**

- This testing method aims to offer users a process for measuring the slump of plastic hydraulic-cement concrete
- Each mix design was batched and was tested for stiffness and workability using the slump cone. This was done with all 15+ mix designs, using a slump cone, a tamping rod, a tape measure, and a base plate

### **Standard Practice for Making and Curing Concrete Test Specimens in the Field (ASTM C31)**

- This test method specifies the proper procedures of curing and making concrete cylinders including the method of removing air content from the cylinder.
- Each batch was slumped and prepared into cylinders to be cured and tested for compressive strength.

### **Standard Test Method for Compressive Strength of Cylindrical Concrete Specimens (ASTM C39)**

- This specification describes how concrete specimens can be checked for compressive capacity.
- For each mix design, three 4 x 8 in. cylinders were created. These were tested using ASTM C39 at 3, 7 and 28 days. This provided useful comparisons for the strength of our candidate mix designs.

### **Standard Test Method for Flexural Strength of Concrete (Using Simple Beam with Third-Point Loading) (ASTM C78)**

- This test uses a simple beam with third-point loading to determine the flexural strength of the concrete through modulus of rupture.
- A meshless beam and a beam with mesh were created in a mold during Pour Day and tested to both determine the flexural strength of concrete and the effect of mesh on the flexural strength of concrete.

### **Guide to Formwork for Concrete (ACI 347-04)**

- Formwork for the female mold was designed with objectives of safety, quality, and economy using this American Concrete Institute manual.

## **7. Appendix D – Technical Deliverables**

Attached are the Mix Design Sheet and Construction Drawings.



**SOLIDS (Powdered Admixtures or Fillers)**

Solids	Specific Gravity	Volume (cf)	Amount (lbs)

Total Solids from Admixtures  
 lbs

**WATER**

		Amount (lbs)	Volume (cf)
<i>w/c ratio</i>	<input type="text" value="0.80"/>	<i>Water = w/cm * cm</i>	<input type="text" value="400.00"/>
<i>w/cm ratio</i>	<input type="text" value="0.4"/>	<i>Free Water from Aggregate</i>	<input type="text" value="0.00"/>
		<i>Free Water from Admixture</i>	<input type="text" value=""/>
		<i>Batch Water</i>	<input type="text" value="400.00"/>

		cm	fiber	aggregate (SSD)	solids	water	Totals
<i>Mass (lbs)</i>	<i>M</i>	<input type="text" value="1000.00"/>	<input type="text" value="0.63"/>	<input type="text" value="602.76"/>	<input type="text" value=""/>	<input type="text" value="400.00"/>	<input type="text" value="2003.39"/>
<i>Volume (cf)</i>	<i>V</i>	<input type="text" value="5.59"/>	<input type="text" value="0.01"/>	<input type="text" value="10.94"/>	<input type="text" value=""/>	<input type="text" value="6.41"/>	<input type="text" value="22.95"/>
<i>Theoretical Density (pcf)</i>	<i>D = M/27</i>	<input type="text" value="74.20"/>					
<i>Total Aggregate Ratio</i>		<input type="text" value="0.41"/>					
					<i>Theoretical Air Content</i>	<input type="text" value="15.00"/>	%

**Measured Properties**

<i>Measured Mix Density</i>	<input type="text" value="74.10"/>	lb/ft <sup>3</sup>
<i>Reported Air Content</i>	<input type="text" value="15.00"/>	%

1 2 3 4 5 6 7 8

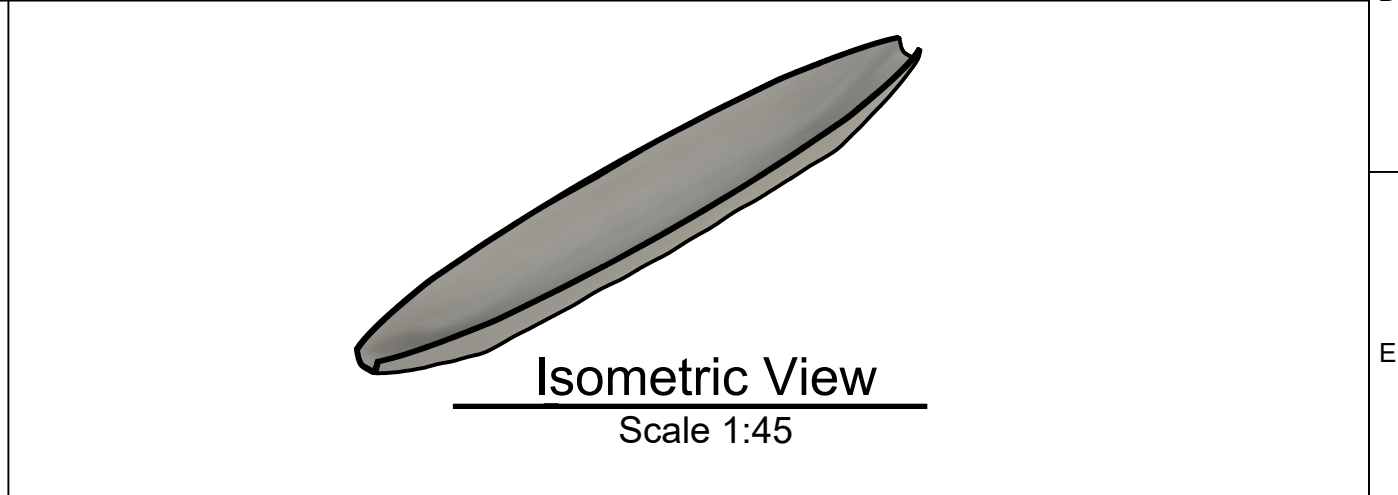
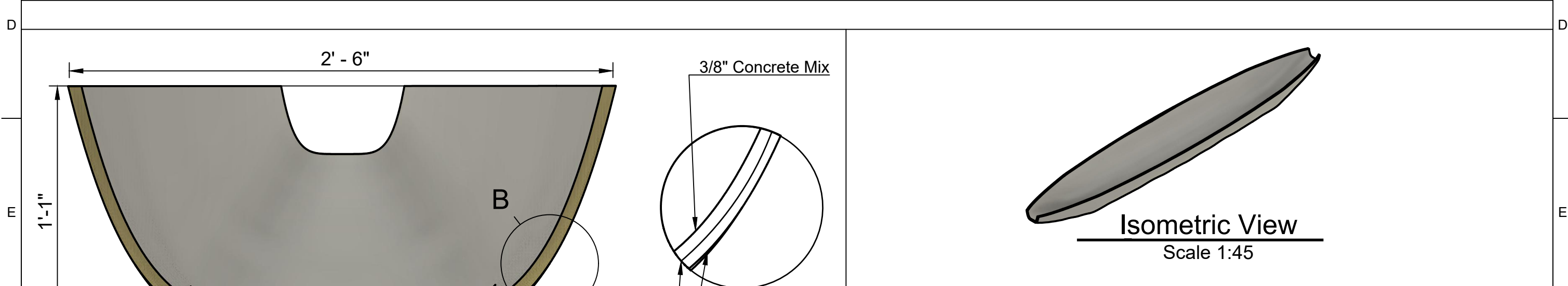
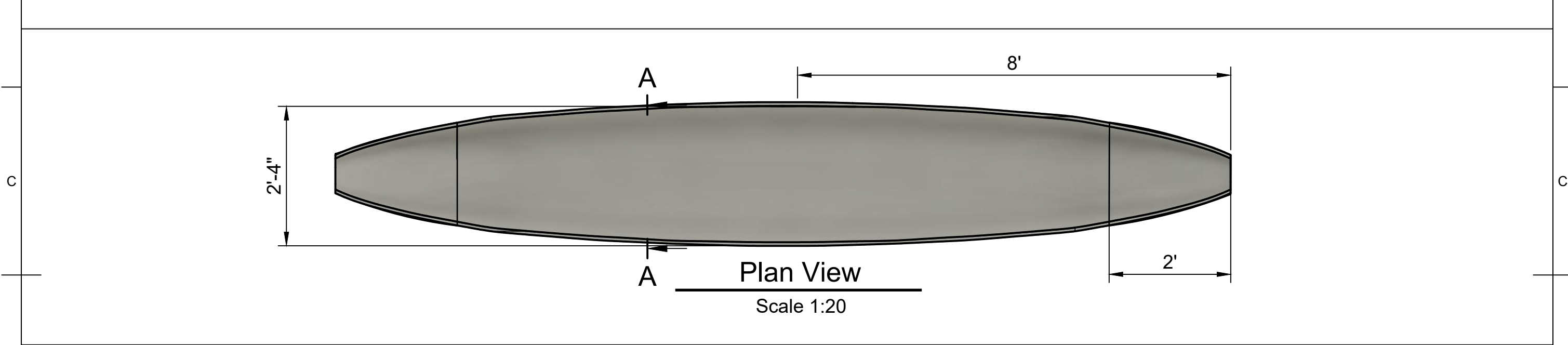
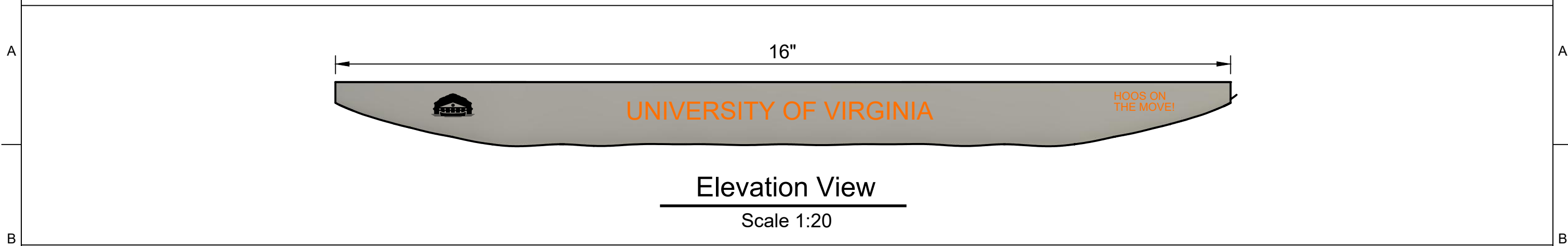

Dept. Construction	Technical reference	Created by Kenneth Reyes 1/18/2024	Approved by Ella Maulfair 1/19/2024
		Document type General View	Document status APPROVED
		Title Concrete Canoe Model	DWG No. <b>Sheet C1</b>
Rev. 5	Date of issue 1/18/2024	Sheet 1/2	

1 2 3 4 5 6 7 8

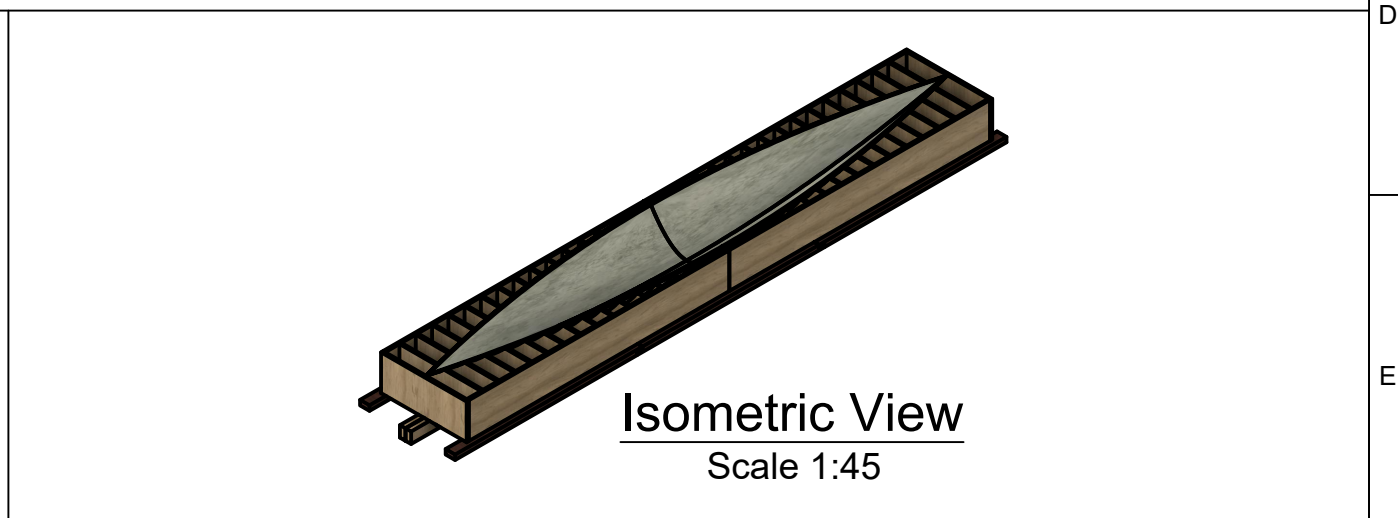
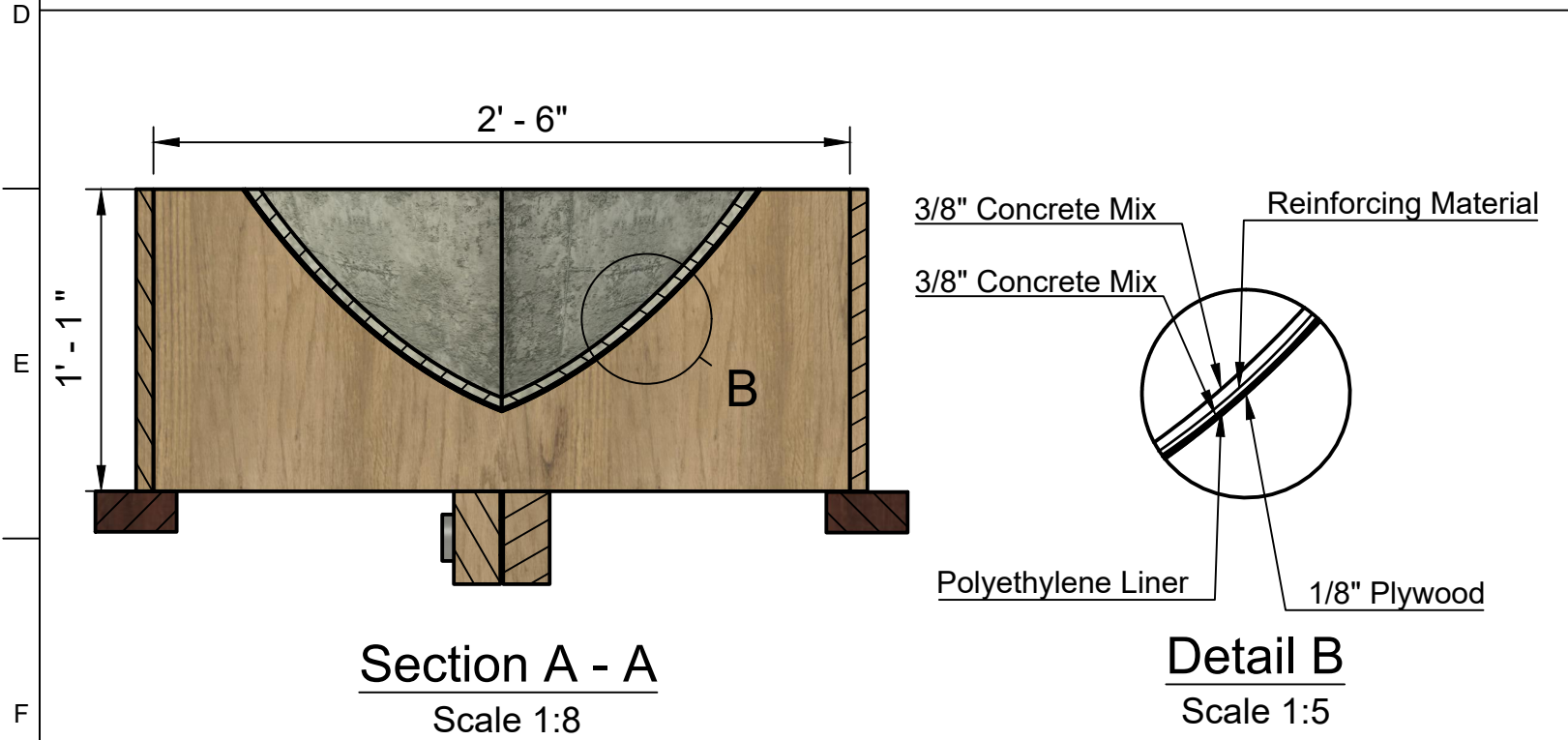
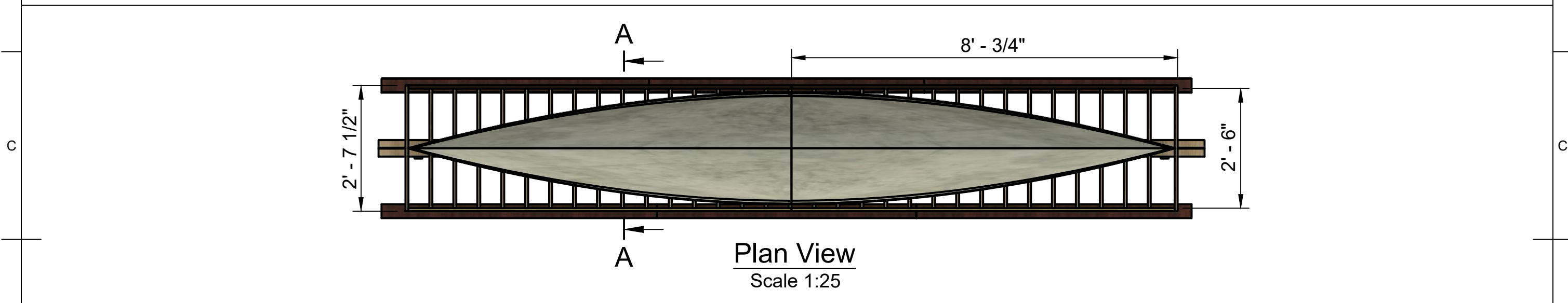
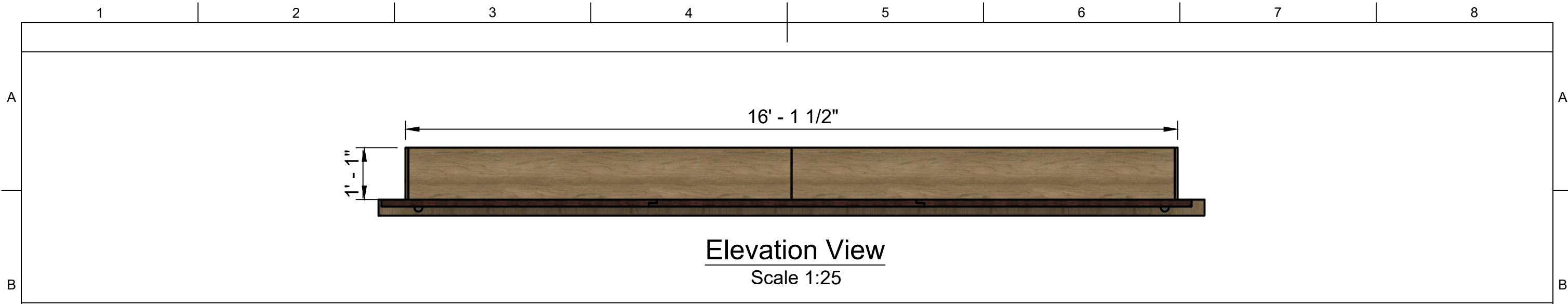

Dept. Construction	Technical reference	Created by Kenneth Reyes 1/19/2024	Approved by Ella Maulfair 1/21/2024
 <p><b>HOOS ON THE MOVE</b></p>		Document type General View	Document status APPROVED
		Title Mold Detail Design	DWG No. <b>Sheet C2</b>
Rev. 5	Date of issue 1/19/2024	Sheet 2/2	

**8. Appendix E – 2024 Virginias Symposium Scorecard**

