

Adaptive Trailer Hitch System

A Technical Report submitted to the Department of Electrical and Computer Engineering

Presented to the Faculty of the School of Engineering and Applied Science
University of Virginia • Charlottesville, Virginia

In Partial Fulfillment of the Requirements for the Degree
Bachelor of Science, School of Engineering

Shrisha Yapalparvi

Spring, 2024

Technical Project Team Members

Cole Blackman

Taylor Ney

John Skiles

On my honor as a University Student, I have neither given nor received unauthorized aid on this assignment as defined by the Honor Guidelines for Thesis-Related Assignments

Adam Barnes, Department of Electrical and Computer Engineering

Amanda Watson, Department of Electrical and Computer Engineering

ECE 4440/4991 Embedded Systems (Capstone) - Adaptive Trailer Hitch System

Cole Blackman, Taylor Ney, John Skiles, Shrisha Yapalparvi

Spring 2024

Contents

1	Statement of Work	3
1.1	John	3
1.2	Cole	3
1.3	Shrisha	3
1.4	Taylor	3
2	Abstract	4
3	Background	4
4	Societal Impact Constraints	6
5	Physical Constraints	7
6	External Standards	8
7	Intellectual Property Issues	10
8	Project Description	12
8.1	Performance objectives and specifications	12
8.2	How the product works	13
8.2.1	Electrical Circuitry	13
8.3	Technical details	19
8.3.1	Electrical Technical Details	19
8.3.2	Mechanical Components	22
8.3.3	Analysis (Reversing Maneuverability)	26
8.3.4	Mathematical Analysis (Sway Mitigation)	29
8.3.5	Software	31
8.4	Test plans	33
8.4.1	Hardware Testing	34
8.4.2	Software Testing	35
8.4.3	System Testing	37

9	Timeline	37
10	Costs	41
11	Final Results	42
12	Future Work	45
13	References	46
	APPENDICES	48
A	Budget Outline	49

List of Figures

1	Properly Securing a Trailer [8]	9
2	System-level view of the electrical portion of the product.	14
3	Block diagram of product	15
4	'Power' PCB schematic	16
5	'Signals' PCB schematic	16
6	'Signals' PCB board layout	17
7	'Power' PCB board layout	18
8	Analog Discovery 3 testing pin interface	19
9	Inputs/Outputs to/from each PCB.	20
10	Photograph of the Signals PCB with TI MSP board attached.	21
11	Power board in its 3D printed enclosure.	22
12	Photograph of prototype, connected to a golf cart testing vehicle.	25
13	Sensor Mount Assembly	26
14	Illustration of the Active Hitch Adapter's impact on trailer maneuverability and safety	28
15	Python code for computing required damping force	31
16	Software flowchart for reverse runtime	32
17	Code listing for reverse runtime	33
18	Original Gantt chart for Papers and Presentations, Simulation, Physical Components, and PCB	38
19	Original Gantt chart for PCB, Embedded, Physical Structure, and Testing	39
20	Final Gantt chart for Papers and Presentations, Simulation, and Physical Components	40
21	Final Gantt chart for PCB, Embedded, Physical Structure, and Testing	41
22	Turn Radius With (Left) and Without(Right) Hitch System	42

1 Statement of Work

1.1 John

My key contributions to this project were as follows. During the planning phase, I performed mathematical analysis to determine the feasibility of sway mitigation and the performance requirements of a turn-assist-focused actuator. I was the primary author of the test plan, which specified procedures and requirements for verifying the functionality of hardware, software, and the fully integrated system. I performed PCB testing. I assisted with the original design of the sensor mounting assembly and designed 3D-printed multiple subsequent iterations. I altered and 3D-printed enclosures for the PCBs. I assisted with system-level testing.

1.2 Cole

I worked on most of the subtasks within this project. I designed (including electrical schematic, placement, and routing) one of the two PCBs and worked on the architecture of the electrical system, including how to interact with power and signals from the tractor and trailer. I took a system-level view of the product and managed physical manufacture and design.

I did the mathematical analysis of sway (the bicycle model part) and soldered the boards. I also did the physical manufacturing (of anything not 3D-printed) and designed the rail system.

1.3 Shrisha

Worked across multiple categories in this project. Towards the beginning, aided in finding a platform for simulation, including working in Matlab Simulink and Unreal Engine, and eventually deciding on using BeamNG. Helped select actuator and actuator control board, and once it arrived, tested them. Helped with designing power board and signals board, and once assembled, tested both of them. Helped with redesign of both boards as well. With final boards, tested, debugged, and corrected issues with grounding and incorrect pin placements.

Led the embedded software aspect, working with the progress being done on the simulation side to implement it on the MSP board. Programmed GPIO pins, ADC, and PWM module to read from sensor and output to the actuator control board. Helped in final system testing and collection of data in real world. Helped create final video script and edited it.

1.4 Taylor

I worked on several aspects of the project this semester. The first was trying to recreate our desired hitch system in several simulation platforms. At the start I focused on Matlab and its RoadRunner extension but was ultimately successful creating our hitch in BeamNG. Once the hitch was working in the simulation,

I was able to setup scenes to display the functionality of our product in the simulated environment.

I also worked to design the schematic and layout of our signals board which interfaces with the sensor, actuator, and microcontroller. This required scaling down the sensor's output voltage and providing the appropriate signal paths to and from the microcontroller. I also helped with the overall design and component selection for the sensor and actuator.

2 Abstract

This Adaptive Trailer Hitch System project is a system that enhances trailer maneuverability and safety by employing a linear actuator to adjust trailer connection point laterally along the truck's bumper. Controlled via a yaw measurement system, this adjustment facilitates improved maneuverability in reverse maneuvers. The same device also addresses a critical safety issue, aiming to mitigate the trailer sway responsible for around 39,000 annual road accidents in the US [3]. Unlike existing systems, the adapter was designed for easy installation and removal, making it accessible for widespread use. The final deliverable was a prototype incorporating custom PCBs, a linear actuator/carriage, rotary encoder, and embedded micro controller board, all housed on a steel attachment. Maneuverability was tested by attaching the system to a truck and trailer, demonstrating notable improvements in turning capabilities in reverse. Sway mitigation was evaluated through soft-body physics simulation at various speeds. The project tasks were allocated based on group members' strengths and conducted in parallel to maximize efficiency in both development and testing phases of the Adaptive Trailer Hitch System.

3 Background

The primary challenge addressed by this project is the difficulty maneuvering a truck / trailer system when reversing. The goal of this project is to design a hitch attachment that, by laterally shifting the connection point of the trailer to the vehicle, reduces the minimum turning radius. This allows for easier entry into tight spots, making driving trailer in reverse easier. A secondary application of this device is to mitigate trailer sway. By moving the trailer to counter the rotation that causes trailer sway, this device can use the same motion and similar programming to assist with both turn radius and sway mitigation. Because the design is interchangeable, this product can be purchased by individuals who tow trailers frequently, or by large companies such as U-Haul that can add this product as an add-on.

The physics inherent to operating a standard trailer pose numerous risks and challenges to the operator. When a trailer is attached to a truck, the effective wheelbase of the system increases, which increases the turning radius. This makes it more difficult to maneuver the truck-trailer system, both going forward

and in reverse. This is made even more difficult for people with little experience driving with a trailer. This is partially the reason why there are nearly 39,000 accidents in the US every year involving trailers, causing 1.2 deaths and 60 injuries every day [3]. Another reason that accounts for most of these accidents is trailer sway, a dangerous phenomenon that describes the non-attenuating oscillation of a trailer at high speeds [14]. This can be caused by multiple factors including wind, steering, uneven road conditions, or obstacles on the road [13]. Whatever the cause may be, trailer sway can grow until the oscillations become so large, it pulls the truck and trailer off their intended path and causes an accident.

Ultimately, we chose this project not only because of its real world importance, but also because it enabled us to deepen our expertise through the challenges of cross-disciplinary engineering solutions. It is fundamentally an electro-mechanical system, with full scale prototyping and large forces to contend with.

There exist several technologies to mitigate trailer sway, some implemented in the hitch attachment and some integrated into the trailer itself. Hitch-centric methods include hitch attachments with designed stiffness to make the trailer less prone to rotation. Equal-i-zer's Integrated 4-Point Sway Control system, for example, uses steel connections from the hitch to the trailer with built-in friction to passively prevent the trailer rotation that causes sway [12]. Active systems also exist to counter trailer sway, but they require integration into the body of the trailer; Bosch offers a sway control system that implements asymmetric wheel-braking to prevent trailer sway [1].

A similar study this was done previously by Conner Fry Sykora at the University of Waterloo with a particular focus on trailer sway mitigation [13]. While there are some key differences between this implementation and Sykora's (Sykora's model used hydraulic actuation, not electric), the Sykora paper provides thorough analysis of the dynamics of a truck-and-trailer system and the physical requirements of an attachment that should be able to rotate a moving trailer. Further, the Sykora paper mentions the potential application of such an attachment to assist with optimizing trailer turn radius, validating the dual functionality of the intended device [13].

As for trailer maneuverability devices, there are no active solutions. Current solutions either add a camera or sensor in the back that gives the driver a better view of the situation while they are in the car. This includes devices like TowGo's Trailer Backup Navigation Aid, which displays sensor readings, allowing the driver to see things they would not have otherwise been able to [28]. Another is DrawTite's Trailer Hitch Alignment System, Backup Guide which uses large, bright bulbs so the driver can better see the position of the trailer [10].

While elements exist to actively mitigate trailer sway and assist with turning by extension, none are interchangeable, with most requiring some integration into the design of the trailer. This is limiting, as a typical consumer is unable to independently and safely alter the design of their trailer to achieve the desired effect. Passive systems like the friction-based Equal-i-zer hitch can be

interchangeable but cannot be programmed to differentiate between turn radius and trailer sway. Even the Sykora design, which aimed to be a versatile, active solution, required specific modifications to the car and trailer to accommodate the attachment [13]. For trailer maneuverability, none of the devices are active, only passive. The novelty of this design lies in its active and interchangeable implementation, requiring the user only to slot it into place, connect the 7- and 4- pin connectors to truck and trailer, respectively, and attach the sensor.

This project primarily pulls from the work completed in all of the Electrical and Computer Engineering (ECE) Fundamentals (FUN) courses and Introduction to Embedded Computer Systems (Embedded). Each FUN course provided part of the necessary foundation in ECE knowledge to complete an involved project in electrical and computer engineering. More specifically, FUN II and FUN III each provided experience with PCB design, which was a key element of physically implementing an electronic device. The curricula of FUN II and FUN III also dealt with control systems, applicable to designing the embedded code to increase maneuverability and safety. FUN III and Embedded both provided experience with digital signal processing, which work in combination with control system design to accept an analog signal and generate a response based on the digital reconstruction of the input. The material covered in Embedded correlates strongly to the programming a microcontroller to determine the behavior of the active hitch attachment.

4 Societal Impact Constraints

Our primary stakeholders and users are individuals and companies who tow using vehicles equipped with 2 inch hitch receivers. The purpose of towing a trailer can vary from farm use to landscaping and movers. This product has a general impact of increased safety and maneuverability, so regardless of use case, as long as the device is being used as intended, it stands to benefit all use cases. Companies such as U-Haul or distributors of goods who use trailers and hitches as an integral part of their operations should be very interested in something that makes their trailers safer and more maneuverable. The drivers, whether individuals or part of a company, stand most to benefit from our product since it is their safety and experience that is improved.

The drivers using our hitch will be able to maneuver their trailers easier and mitigate the sway they experience. They and the drivers around them are invested in our device functioning and behaving as expected in order to improve safety on the roads. Trailer and vehicle manufacturers are also stakeholders in our device, they would appreciate an interchangeable hitch that abides by already established and used standards. Our hitch makes it easier for them to keep manufacturing their vehicles without having to consider how additional equipment may be needed to help safely tow or maneuver a load.

Other companies that currently produce custom hitches or hitches designed to help the driver in reverse are also stakeholders. They may be interested in investing in our device or see it as competition to their solutions. US and

State safety regulators are additional stakeholders due to the safety applications of future derivations of our device. The DMV and organizations such as the Department of Transportation may also be invested in the safety benefits of our product as well as its functionality. If it can make the job of trailer-drivers easier, then our device could be something they want to recommend or implement at a larger scale.

This semester, the manufacturers of our PCB and sensors also serve as stakeholders since they provided us with the materials to create our device. If there were something wrong with those materials or a fault caused our device to malfunction while in use, they would have to become more involved. Similarly, if our device becomes commercially viable, they may become suppliers or be competing with other manufacturers to provide parts.

From an environmental point of view, the use of the device has negligible impact, since the only energy being used is when the trailer is reversing or when sway is detected, which, for the majority of the ride, will not be happening. It pulls power from the truck itself, but at a low enough current draw that minimal additional load is placed on the alternator. Socially, the product is marginally more work to use than a standard trailer hitch, meaning there is minimal friction in deciding between a passive and active hitch. Novice operators may be more willing to pay the additional cost of the active hitch due to safety concerns, and large companies like U-Haul can install these in bulk to keep damage to their fleet and insurance costs down.

5 Physical Constraints

When first presented with the outline of the capstone project, the most evident constraints were time, money, and safety. This shaped the design of our project, pointing to addressing the issue of trailer control. Time was a significant constraint on the project. For example, we would have preferred to make multiple prototypes and attempt to construct our hitch on a small scale (such as remote-control scale) initially, but we decided to go straight into the construction of a full size hitch from simulation. The time constraint also came into play when iterating on PCB designs. Given more time, we would have ordered a new PCB, but due to time constraints, the same PCB was rigged with shunts and jumper cables to make it work.

For the cost constraint, we had a limit of only \$500. Cost limitations were the main reason we decided against pursuing physical mitigation of trailer sway, as actuators with enough power for this application were all well over budget. Cost also played into our decision not to build a small scale model. That would have involved purchasing an RC car, separate actuators, and possibly an additional PCB. Ultimately, we decided that with the timeline and budget of our project, we would focus on trailers of 3,000 lbs or less. This eliminated the need to incorporate trailer brakes, which are required for trailers above 3,000 lbs in the state of Virginia [9].

Safety constraints were another concern that ultimately led us away from

physically applying sway mitigation to the device. We came to the conclusion that the only safe way to demonstrate that our hitch worked on a full scale was to have it move while the trailer was static or at very low speeds. Because low speed conditions would be inadequate to induce sway, we decided that we would be unable to test its mitigation and thus unable to complete development of a mitigating device. Due to the aforementioned cost and safety challenges, we shifted the primary focus of the project to improving maneuverability for ease of trailer operation. Trailer sway was still addressed in simulation, however.

As part of development of this project, multiple tools, both hardware and software, were used. For design, development, and ordering of PCBs, Altium Designer was used. This was a software that was new to all group members, but was chosen due to its extensive library of components and ability to work collaboratively. Digilent's Analog Discovery 3 was used, along with its corresponding Waveforms software, for testing the PCB boards once they arrived. This helped verify voltages, supply signals, and in unit testing. All group members had experience working with both tools from previous classes. When deciding on a simulation platform, 3 options were considered: Epic Game's Unreal Engine, BeamNG, and Matlab's Simulink. None of the group members had experience with any of the platforms, so they were something that needed to be learned. In the end, BeamNG was selected as the platform for simulation where different behaviors of active hitch movements could be tested and iterated upon before flashing it onto the physical device. Finally, to program the micro controller, C code was used through the Code Composer Studio software. Group members had experience with both C and Code Composer Studio from previous classes, but a refresh on the MSP432's APIs was required.

6 External Standards

Legally, we had to ensure that our hitch system complied with all state and federal regulations so it could be used on all roads and highways. In title 46.2-1118 of the Code of Virginia, there are several stipulations relating to trailer hitches including structural adequacy for the weight being towed and presence of a locking device to prevent separation [26]. The full excerpt and further regulations are shown below. Additionally, only trailers with 4-pin connectors are supported. This allows us to utilize the full power provided by the truck to the trailer system (typically 12V fused at 20-30A) without worrying about blowing a fuse when the trailer brake gain is high enough to draw close to the full power. This means that the system only works with trailers that do not have trailer brakes and with trucks that have 7-pin braked trailer wiring.

The Code of Virginia has requirements relating to the connection point between a vehicle and its trailer. An excerpt relating to connection points is shown below.

"The fifth wheel, drawbar, trailer hitch, or similar device must (i) be structurally adequate for the weight being drawn, (ii) be properly and securely mounted, (iii) provide for adequate articulation at the connection without ex-

cessive slack at that location, and (iv) be provided with a locking device that prevents accidental separation of the towed and towing vehicles. The mounting of the fifth wheel, drawbar, trailer hitch, or similar device on the towing vehicle must include reinforcement or bracing of the frame sufficient to produce strength and rigidity of the frame to prevent its undue distortion” [26].

When fabricating and designing the hitch, we had to ensure that it met all the requirements described in the excerpt above. For example, for the design to be structurally adequate, we had to ensure that the weight of the trailer was supported by the hitch ball, not by the actuator. Our trailer-hitch setup was very important for meeting all regulations while testing full-scale. The state requirements are further elaborated in a pamphlet created by the Henrico County Police Division. In addition to a bullet point list of hitch requirements, it includes a graphic, shown in Figure 1, of how to properly secure a trailer [8]

Figure 1: Properly Securing a Trailer [8]

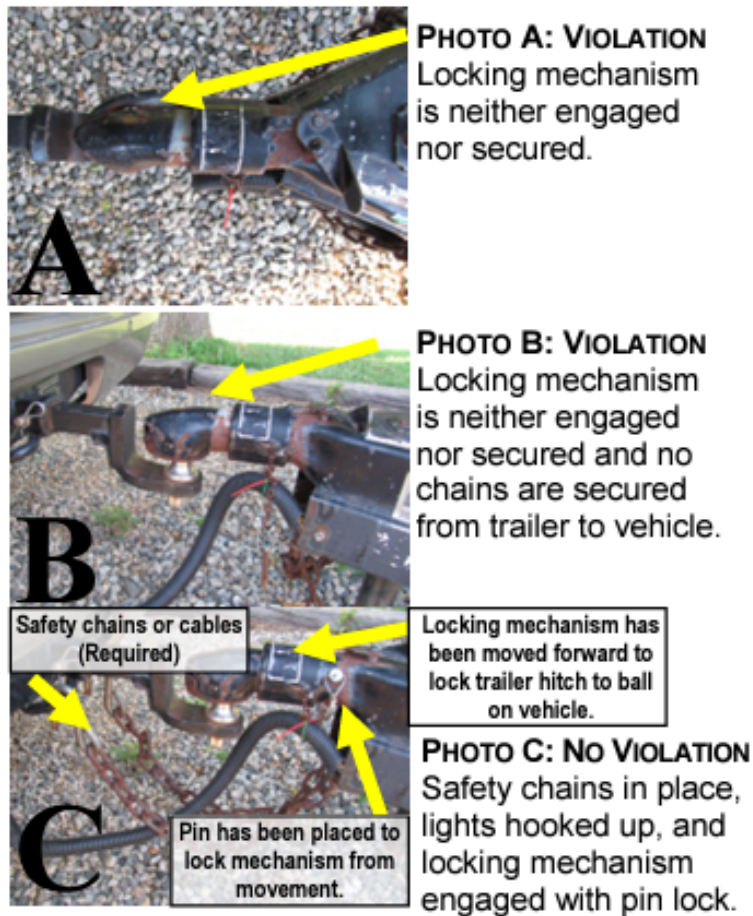

The power drawn for our PCB and micro controller comes from a 7-pin connector which traditionally brings power and signals from the truck to the trailer. Our hitch will need to connect to this point and then re-attach back to the trailer. These 7-pin connectors are standardized by the ISO [20]. To power our hitch, we needed to understand the standards of the connectors and ensure that all of our connections were compliant. We also had to make sure we understood what each pin did so we can draw power as needed. This also abstracts away the car’s internal power system, since this standard allows us to treat it as a black box and only interact with it through the 7-pin standard. Additionally, when designing and ordering our PCB, we had to follow the IPC-2221 standards for printed circuit board design as well as the manufacturer’s order requirements and best practices. This includes spacing between parts, the widths for different tracks, and the spacing between them [19].

Finally, although there are no hard requirements for waterproofing car attachments in Virginia, this product should have some level of water protection before putting it in the market [27]. The level of protection should be at or above IP65, which protects against jetting water and keeps the enclosure dust tight [18]. This will keep the internal electronics safe from water that can be expected either from rain or from puddles on the road splashing water up as cars drive past. Ensuring the enclosures containing electronics abide by IP65 will protect against electronic malfunctions and the potential for the circuitry to break.

7 Intellectual Property Issues

At the very start of this project, we looked into various existing solutions to trailer sway and aids for reversing trailers. We found that most of the existing solutions passively responded to sway through adding rigidity to the truck-trailer system and required a permanent installation to either the truck or trailer. As mentioned in the background, our design concept is most similar to that discussed in the thesis paper written by Connor Fry Sykora [13]. His paper details how moving a hitch’s lateral position will alter the truck-trailer yaw angle enough to bring the system out of a swaying state [13]. The proof of concept provided by Sykora gave us the confidence to move forward with our hitch design. Unlike the technology proposed by Sykora, our hitch moves laterally (left and right) and is powered by a linear actuator rather than hydraulics. By allowing for movement in both directions, it gives the hitch the ability to help the user when backing up a trailer in reverse as it can decrease their turning radius. Additionally, through using a linear actuator rather than a hydraulic system, our system is contained within itself and does not require pumps or power sources to be permanently attached to the user’s vehicle or trailer [13].

If we were to patent this product or sell it commercially, based on research into existing patents, we do not believe there would be any intellectual property issues. The hitch system is patentable because it is patentable as a physical product, has everyday utility, and is a novel solution to the problem it solves.

Additionally, the solution is non-obvious and enablement can be fulfilled through a thorough write up and explanation. These requirements will be shown through a look at three existing patents which attempt to solve the same issues.

One of the first patents to address trailer sway is from 1966 and titled "Sway control means for trailers" [23]. This invention mitigates trailer sway by increasing rigidity in the truck-trailer system. A beam is attached to the truck side of the hitch and stretches to mount on the side of the trailer arm. Part of its independent claim is that the hitch provides "Frictional engagement with said bar, and means for controlling the degree of frictional engagement between said bar and brake shoe means" [23]. In essence, the bar applies an adjustable amount of friction to the trailer to keep it from developing sway. This claim does not conflict with our design as we are using the physical change in the truck-trailer angle to reduce sway rather than applying friction to the trailer.

A second invention titled, "Trailer hitch with multi-directional dampening system and spherical rod-end assembly", uses a more advanced form of dampening to reduce trailer sway and trailer bounce [22]. This design uses passive air springs around the hitch ball to provide adjustable and multi-directional dampening. This design is similar to ours in that it is a single hitch which goes directly into the truck and trailer with no additional setup. Where it differs is explained through their independent claim: "said slide block assembly engaging said track for slidable movement therein when one of said frame and said carriage is attached to a tow vehicle and the other of said frame and said carriage is attached to a trailer, said at least one air spring and said movement of said at least one slide block assembly providing multi-directional dampening to reduce transmission of relative motion between said tow vehicle and said trailer" [22]. The reason this is an independent claim is due to its uniqueness in defining the problem. The use of air springs are not in support of another claim or function of the device. An example of a dependent claim from this product is how it is applicable to multiple hitch types including gooseneck and fifth wheel mounts. Despite the overlap in interchangeability, the key difference, as with the first invention is method of applying dampening verses changing the truck-trailer yaw angle. As it states in the independent claim, this is reliant on air springs to dampen the forces experienced by the trailer.

The final invention patent we looked at was an invention which observed the angle velocity of the trailer and sent signals to the trailer brakes to engage in order to reduce trailer sway [2]. This device shares the idea that the yaw angle of the trailer can be used to identify trailer sway and that a controls system can be put in place to counteract that sway. The means of implementing that controls system are very different, however. Our design proposes that changing the lateral position of the hitch is enough to change the yaw angle and bring a trailer out of a sway state rather than manipulating the brakes. Additionally, many smaller trailers such as those for farm and everyday use, do not have brakes installed.

As discussed above, the method of moving a trailer hitch laterally to change the trailer yaw is a novel way to reduce trailer sway. While rigidity helps when reversing a trailer, none of those inventions provide a way to reduce the vehicle's

turning radius. Additionally, the hitch has practical utility to individuals who may be new to towing or use trailers on a regular basis and want to make the process easier. Our design is designed for small trailers under 3000lbs in particular. The physical device has schematics as well as the circuitry. The algorithms for the controls system can be published as well. Through those, the device is patentable as an invention and can fulfill enablement.

8 Project Description

8.1 Performance objectives and specifications

From a user's perspective, the primary use of the device is to facilitate a reduction in turning radius while backing the trailer in reverse. This is designed to be particularly helpful when reversing a truck/trailer system in tight spaces or with other spatial constraints. The secondary objective of the project pertains to mitigating trailer sway. Trailer sway is an oscillatory condition that results in an unstable trailer, typically created by external factors such as rapid steering input or uneven driving surface. Active trailer sway mitigation seeks to offset this oscillation by detecting it and moving the connection point between the truck and trailer closer to one side of the truck or the other.

We explicitly enumerate our objectives as follows:

1. When a user has enabled the trailer sway mitigation feature, the truck-trailer system will experience reduced trailer sway.
2. When a user has enabled the reverse assist feature, and the towing vehicle is in reverse, this project will improve the system's maneuverability, allowing the user to navigate the trailer into tighter spots.

Specifications therefore included the following:

- Safety mechanisms were incorporated to prevent over correction or interference with normal driving. For example, to ensure the trailer behaves predictably and safely during turns or banking maneuvers, even if the turn signal is not engaged.
- The device was engineered to be compatible with a broad array of truck and trailer configurations commonly found in the market.
- The product was crafted to enhance a driver's ability to maneuver the trailer in tight spaces during reverse operations and to decrease overall turn radius. Additionally, it was designed not to necessitate any additional connections beyond the 2" hitch receiver and a standard 7-pin connector.
- Real-time exposure of the 4-pin interface was ensured, unaffected by the movements of the adaptive hitch.

- Emphasis was placed on retaining standard safety features like chains and rapid disconnects alongside the installed product. The product should minimize altering the status quo of towing in order to retain familiarity by the operator.
- The product was engineered to operate autonomously without requiring driver input.
- Designed to be toggleable through the use of a switch, functioning as a conventional hitch when deactivated.
- Protocols for reducing turning radius and mitigating trailer sway were designed to be independently toggle-able.

8.2 How the product works

These objectives were accomplished through the use of an adaptive trailer hitch capable of moving the connection point between truck and trailer side to side (parallel to the the axles of the vehicle). While in a turning condition in reverse, shifting the trailer connection towards the outside of the arc reduces the effective wheelbase of the system. This means that with the adaptive trailer hitch system, a smaller turning radius and turning angle can be achieved.

The exact same actuator and linkage (dictated by a micro-controller executing a control system) can detect and reduce trailer sway by counteracting the lateral movement of the trailer, though, again, it may be under-powered for this application [15]. A rotary encoder transducer detects the truck-trailer angle [11]. A block diagram is shown in Figure 3 below.

8.2.1 Electrical Circuitry

We begin specification of the electrical component of this project with a broad overview of the printed circuit boards (PCBs) involved and their inputs/outputs.

- "Power" Board (custom PCB, designed for this project and ordered from JLCPCB)
 - **How it is used:** Responsible for converting the power source from the 7-pin to voltage levels that could be used by the rest of the board (12V, 5V, and 3.3V). Also responsible for routing to the 4-pin.
- "Signals" Board (custom PCB, designed for this project and ordered from JLCPCB)
 - **How it is used:** Hosts the micro-controller and directs voltages from the sensor, to the micro-controller, and signal from the micro-controller to the LAC. Provides power to the sensor.
- Linear Actuator Control (LAC) Board (commercially available from Actonix)

- **How it is used:** A black boxed piece of hardware that takes in power for the actuator, and a PWM signal to move the actuator. Duty cycle of incoming PWM signal determines the position of the actuator.
- Texas Instruments MSP 432 Microcontroller (commercially available from Texas Instruments)
 - **How it is used:** Hosts embedded code for the logic and algorithms of the device. Processes data from the sensor and the truck's outputs.

Next, we provide two diagrams to visually demonstrate both the division of responsibilities to each board and also the flow of signals and power. First, a system-level view to demonstrate the 6 inputs and 5 outputs from the electrical system as a whole in Figure 2. This diagram also shows how we separated grounds between the 12V actuator and the "low" voltage 5V/3.3V shared ground. An important note on this diagram is that the signal driving the behavior of the actuator is generated in the micro controller, sent to the LAC driver board, and forwarded to the linear actuator. This allows us to utilize the flexibility of the LAC architecture instead of creating a custom motor driver with feedback. Not shown is any proprietary communication back and forth between the LAC driver board and the linear actuator, as this is abstracted away by the LAC driver board, which exposes only a flexible interface.

Figure 2: System-level view of the electrical portion of the product.

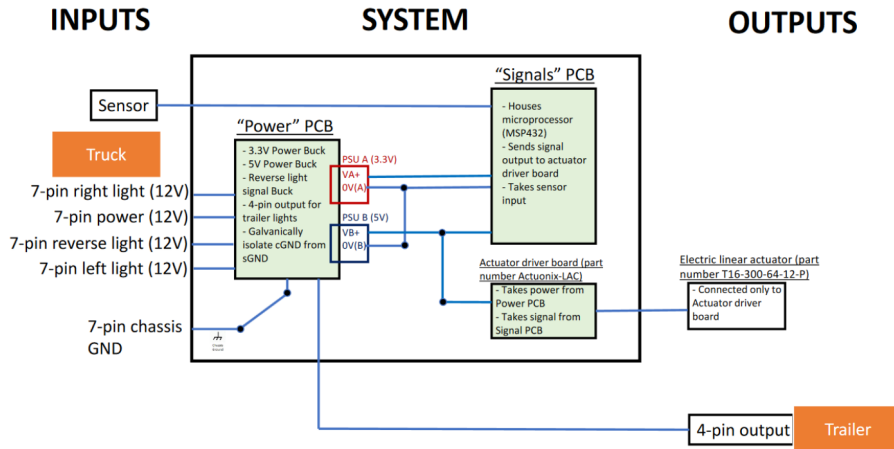
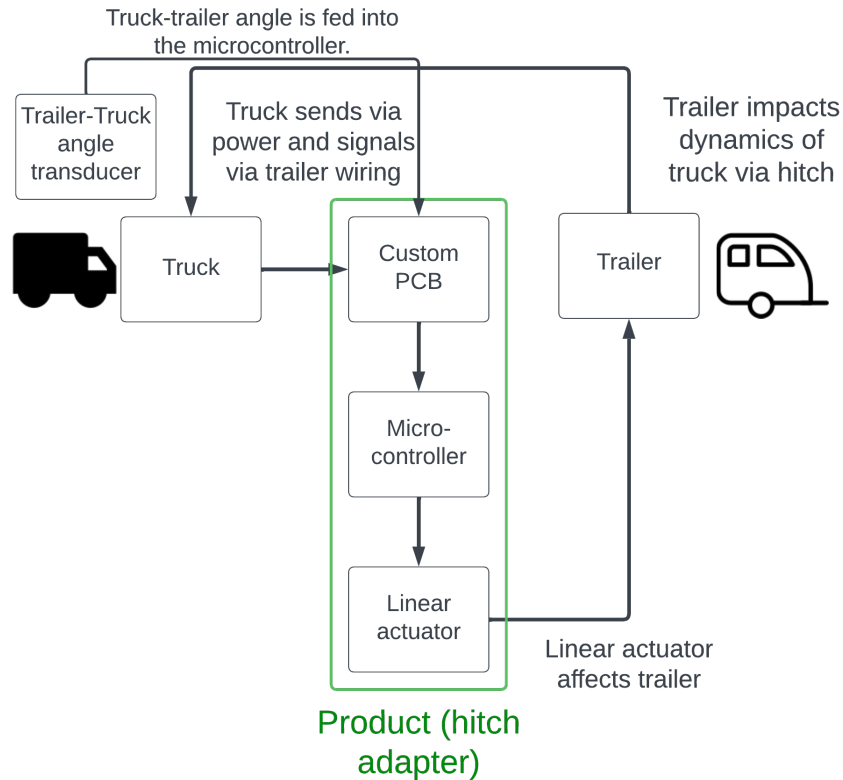

Figure 10 shows a more detailed view of what connections are made between each electrical component in our design.

Figure 3: Block diagram of product



Now we can dive into the schematic-level view of how the two custom boards are designed. One important note first, however- due to a damaged circuit board, in the final prototype we used an adjustable buck converter for the 5V supply in place of the subcircuit embedded into the custom Power PCB. We do not expect this issue to occur if the PCB were created again with this design because the 3.3V circuitry, which is identical, functions as expected.

Figure 4 shows the layout of our power delivery circuitry. This circuitry is mostly straightforward. The "BoardOutput" label corresponds to the output 4-pin that provides lights and turn signals to the trailer. Because we are intercepting the 7-pin and using it for the product's purposes, we need to passthrough 4 of the 7 signals to the trailer (left turn signal, right turn signal, running light, and ground). While most vehicles with 7-pin trailer connections also have a 4-pin trailer connection, and theoretically both could be connected at the same time, this could potentially cause issues on some newer vehicles which do not expect both connectors to be in use at the same time.

Figure 4: 'Power' PCB schematic

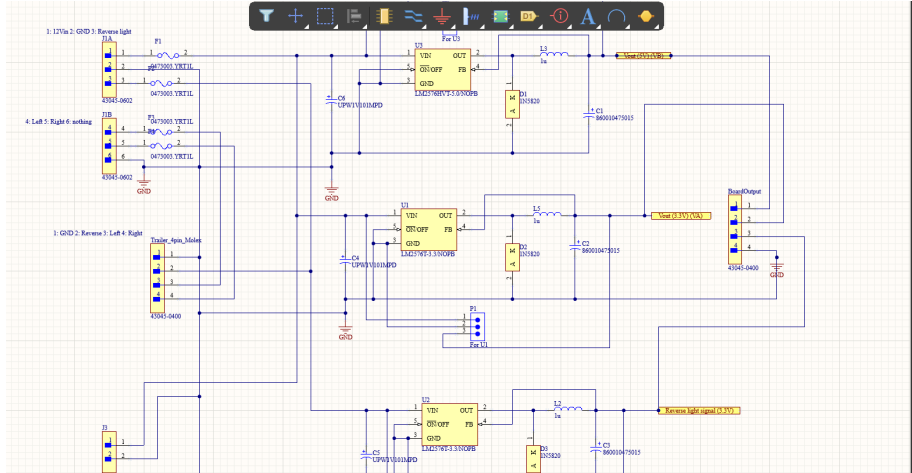

The 'Signals' PCB is detailed in Figure 5. This board has a set of jumpers (P1, P2, P3, and P4) which allow sample input to be delivered from a 30 pin connector designed for use with Digilent's Analog Discovery 3 (AD3). We implemented this feature so that the entire board, including the input and output to/from the MSP board, could be powered and tested from an AD3. To understand how this feature works, refer to Figure 8, which is a layout showing what each pin on the AD3 does when connected to this 'Signals' board. W1 and W2 serve as power supplies and must be set to the voltage values in the table for the board to work in this mode. Also, jumpers must cross pins 2 and 3 on P1, P2, P3, and P4. When the product is past testing and is used with a 7-pin JST on an actual vehicle, switch the jumpers to the 1 and 2 pin position.

Figure 5: 'Signals' PCB schematic

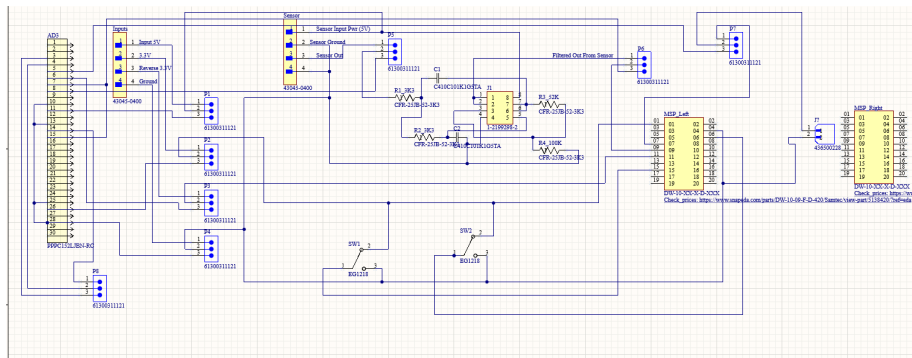

The next step is the placement and routing of the boards. We chose large PCBs because we had minimal size constraints and it made manufacturing and

testing easier. These boards could be shrunk by a significant amount if needed. One interesting note is that for the signals board, components are all placed to the left side of the board to make room for mounting the MSP microcontroller on the right. Our methodology in routing the boards was mostly to optimize the placement of the Molex headers so when the PCB enclosures were completed wires would be routed naturally. Also, we wanted the female 7-pin connector to face the truck and the male 4-pin connector to face the trailer.

Figure 6: 'Signals' PCB board layout

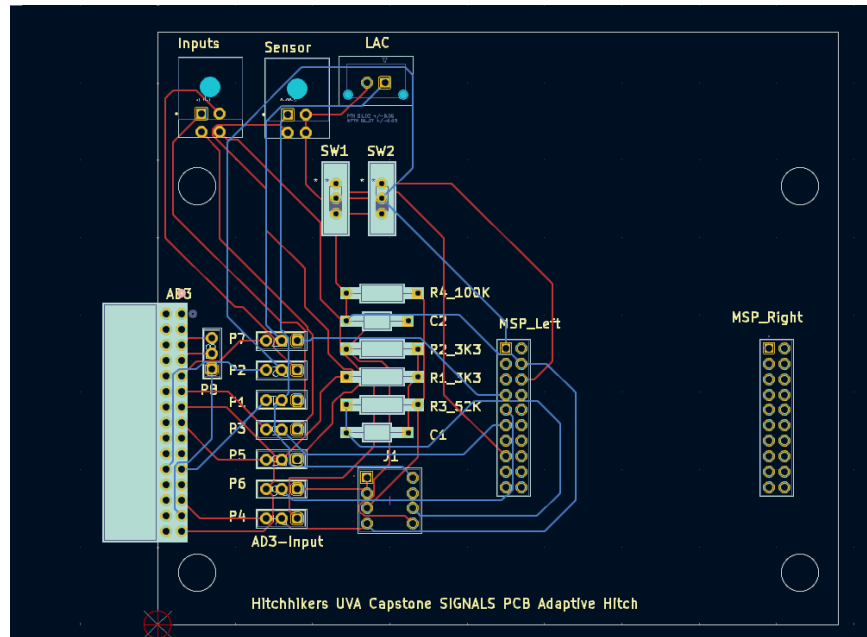

Figure 7: 'Power' PCB board layout

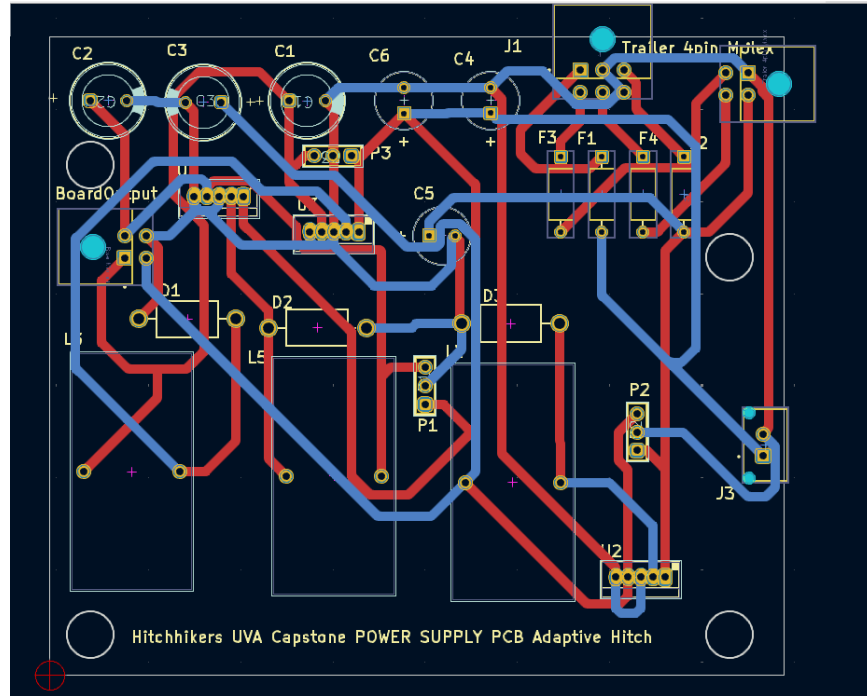



Figure 8: Analog Discovery 3 testing pin interface

AD3 Testing		
AD3 Pin	Node	Input/Output (from AD3's perspective)
D0	Data from PIHER sensor	Input
W1	5V Power	Output
W2	3.3V Power	Output
D1	Filtered (stepped down PIHER sensor)	Input
C1	Filtered (stepped down PIHER sensor)	Input
D2	Trailer reverse light signal	Output
D3	Actuator signal (to LAC)	Output
D4	To exposed jumper	Multipurpose
D5	To exposed jumper	Multipurpose
C2	To exposed jumper	Multipurpose 

*GND should be tied between AD3 and sGND.

**C1 and D1 are electrically connected.

8.3 Technical details

8.3.1 Electrical Technical Details

From a physical manufacturing perspective, these connections are primarily mini-molex (branded as Mini-Fit 3.0 by Molex). This was a design decision made for several reasons. For one, mini-molex provides -40 to +105 degrees Celsius rated operation, which is appropriate for a device that is designed to be operated outdoors [24]. Additionally, you can flow 13A of current and the mini-molex connector family is a comprehensive product offering, with nearly every possible combination of pinning available [24]. As a group, we also had experience with this connector type, so it was a natural choice. We were able to source pigtailed so no crimping was required. We also considered standard Molex connectors as an alternative, but decided there was no need to use the larger footprint connectors with our limited current requirements.

Figure 9: Inputs/Outputs to/from each PCB.

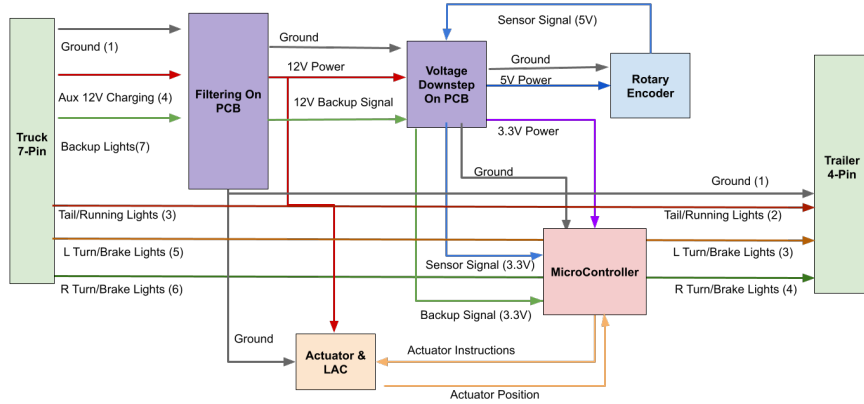

Our system is powered by the truck, which provides steady 12V to pin 4 of the 7 pin connector. We used buck converters to convert that 12V into 5V and 3.3V to power a rotary encoder sensor and a Texas Instruments MSP430 microcontroller, respectively.

Another design decision was to mount the TI MSP board directly to the 'Signals' PCB (see Figure ??). This helped us save space in our containers and simplified the electrical connections. We made sure to include plenty of test pins though, as it becomes harder to test different voltages with this configuration otherwise.

Figure 10: Photograph of the Signals PCB with TI MSP board attached.

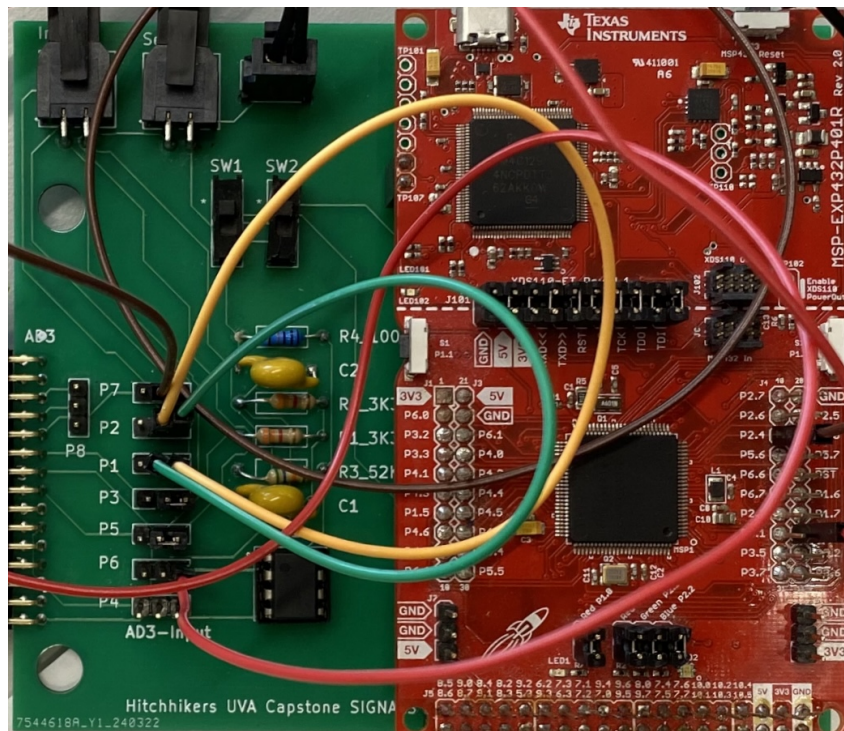

We faced another design decision in board encapsulation. We needed something water-resistant (IP-65, ideally), and with a small enough profile to mount to the underside of the device. We ultimately determined that cast aluminum PCB enclosures would be ideal. They are durable and come in waterproof gasketed variants up to IP-67. In particular, Hammond manufacturing produces die cast aluminum enclosures with mounting risers and plates for use with board standoffs [16]. They also include mounting solutions that could interface with welded tabs on our product [16]. However, this product was not within our budget, so we 3D-printed custom standoffs and used construction glue to secure them to a 3D-printed housing, with silicone as a gasket material. You can see the holes in the PCBs we specified during placement and routing in Figure 11. These boxes were then glued to the underside of the steel gusset. This solution is functional for this proof-of-concept prototype, but any final product would require a solution as described above (die cast boxes) for durability and rated waterproofing. For routing wires through the sides of the boxes, we simply built in holes into the CAD prior to printing. However, a much better way to do this would be spacing the Molex headers off the board slightly so they can fit into a square hole laser cut or waterjet into die cast aluminum enclosures. The gap could be sealed with silicone sealant. The advantages to this approach would be the boxes could stay sealed when removing or connecting Molex connectors.

It would also be significantly better for waterproofing. We did not use this solution because we performed design for the enclosures after the PCBs had already arrived and been populated.

Figure 11: Power board in its 3D printed enclosure.

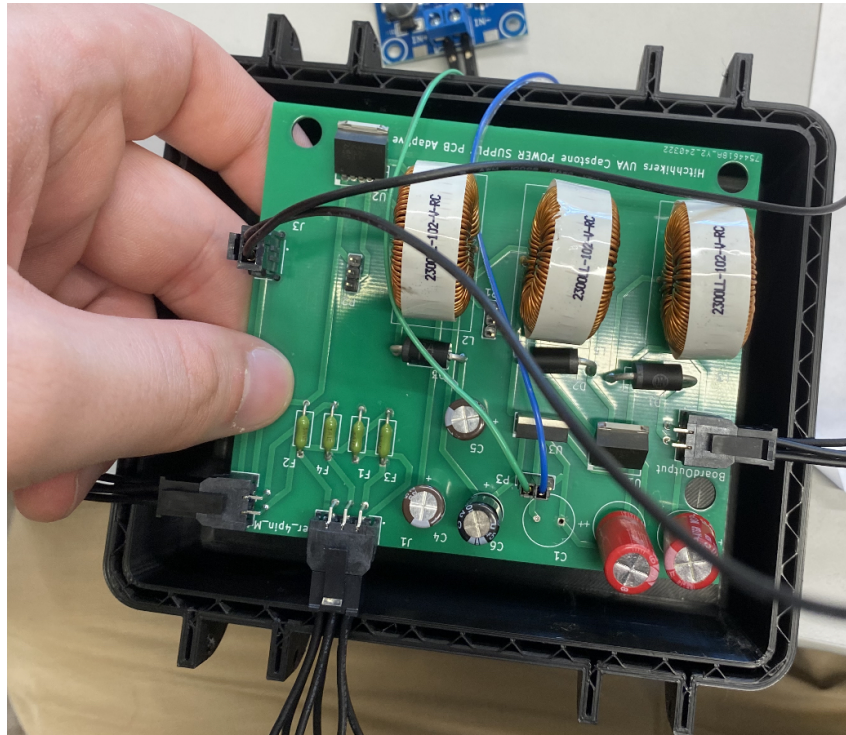

8.3.2 Mechanical Components

A linkage connects the 2" hitch from the truck side to another 2" channel on the trailer side, which moves laterally. In our prototype, we ultimately made the engineering decision to utilize a linear rail on which the trailer ball slides. This is a design decision, and we considered many other possibilities. One such possibility is a Scott Russell linkage, which is a linkage that can convert linear motion in one direction to linear motion in the perpendicular direction. By altering the lengths of the connecting arms in such a linkage, a linear actuator's torque could be multiplied or divided, depending on other design constraints (such as desired length of stroke). This linkage would give flexibility at the expense of complexity. Another option we considered was a swiveling design about a central point. The advantage of this option is simplicity and it obviates the need for a linear actuator. A motor mounted at that center point on the hitch could change the connection point of the truck and trailer as desired. This is the technique used in the 2017 paper/prototype "Trailer sway control using an

active hitch” [13]. It is a simple design. However, the motion of the end of the radius arm which holds the hitch ball is not ideal; it moves both in the lateral axis (as desired) and also has a component of motion in the longitudinal axis (to and from the bumper of the truck). We anticipated increased difficulty and complexity in using designing algorithms with this type of motion. Additionally, such a linkage requires a greater distance between the truck and trailer which increases turning radius in reverse, which would actually work against our stated goal. A simple (“1-bar”) lateral linkage ended up being our design choice for this prototype.

After selecting a linkage type, we began the search for an appropriate driver for the linkage. There are three possibilities in common use for linear actuators on this scale (disregarding piezoelectric actuators due to scale): pneumatic, electrical motor, or hydraulic [6]. Beyond these generic considerations that are always front-of-mind when selecting between pneumatics, hydraulics, and motors, there is one consideration specific to this project. We need to be able to hold the selected position against a dynamic and high load- the swaying trailer. Hydraulics are extremely well indicated for this usage because hydraulic pressure, once it has been built, does not disappear or drift. We reason that this means a hydraulic system can lock in place due to the pressure in the incompressible fluid (hydraulic fluid). Hydraulic systems provide high power density, precise control, and are capable of handling extremely heavy loads [21]. They are often used in applications where high force or torque is required [21]. We believe dual opposing hydraulic pistons would be an appropriate solution to this problem. However, for the purpose of this prototype, this solution is too complex. Both hydraulics and pneumatics add significant complexity to the project, necessitating using electric motors to drive either a compressor or pump, respectively. Hydraulic systems require reservoirs, hydraulic pumps, fluid conductors, hydraulic fluid and valves [25]. An electric motor attached to a ball screw (forming a linear actuator) is also a reasonable solution; though there is some backlash, it is capable of retaining (locking) at a certain position. It is also the simplest option.

In our prototype, seen in Figure 12, the tongue weight (the portion of the trailer’s weight that is supported by the truck) of the trailer rests on the linear rail and exerts a binding moment on the rail’s carriage. This is not ideal, as with a loaded or heavy trailer it could cause sticking or binding due to increased friction on the rail. A better solution would include two rails, one positioned closer to the tongue, to distribute the load and prevent either carriage from binding. However, because we were only using an unloaded trailer in this testing demo, this had no impact and we were able to save our budget from requiring a second linear rail and carriage. The linear carriage we used did not include any information on this type of loading, but a review of the datasheet provided for the Hiwin equivalent (Hiwin is something of a name brand, and the manufacturer of our rail stated equivalency with one of their models) confirmed the roughly 200lbs at 12” was within specification for binding loads [17].

A mount was designed to attach one half of the Hall-effect sensor to the hitch ball (truck side) and the other half to the hitch coupler (trailer side). Shown

in Figure 13, the sensor mount was designed with variable fastening dimensions and sensor placement to accommodate for potential variation in hitch and hitch coupler geometry. Components 1-7, as labeled in the figure, were designed in CAD and 3D printed. Component 8 is an anti-rattle hitch attachment that was purchased; it is designed to bolt to the hitch (truck side). The mount is assembled using M6 nuts and bolts. The mount is shown in the figure fastened to a 3D printed representation (component 7) of a standard hitch coupler for a 2 inch ball. Components 1 (of which there are two) fasten laterally to clamp the coupler (7) from both sides by screwing into components 3 and 5. Components 2 clamp vertically onto the underside of the small lip wrapping around the bottom of the coupler (7) by screwing into components 1. Half of the sensor screws into the top of component 4, the position of which can be adjusted vertically using the slots through which its bolts are passed. This half of the sensor is always positioned directly below the hitch ball (the axis of rotation of the trailer). The larger holes on component 6 have the same dimensions as those of component 8, allowing 6 to be bolted to the hitch (truck side) using 8. When bolted to the hitch, component 6 extends through the middle of the coupler-side mount assembly, between components 1, over component 4 (the first sensor component) and under the coupler (7). The remaining half of the sensor screws into the top of component 6 through the long, narrow slots. Its position can be adjusted along the slots to place it in the same vertical axis as the other sensor. Given this configuration, the angle between the truck and trailer can be measured by the sensor, as they rotate on the same axis, one fixed to the truck and the other fixed to the trailer.

Figure 12: Photograph of prototype, connected to a golf cart testing vehicle.



Figure 13: Sensor Mount Assembly



8.3.3 Analysis (Reversing Maneuverability)

We must first very clearly define what is meant by 'turning radius' and 'maneuverability'. Within this paper, maneuverability refers to how tight of a spot one can maneuver a vehicle and trailer into without hitting any of the walls. Specifically, we used the scenario described in Figure 14a, designed to mimic backing a trailer into a parking spot or other tight parking situation. In this scenario, the space is too tight for the truck and trailer to park normally. You can

see that if the operator reduces the angle between the truck and trailer further in an attempt to park the trailer, jackknifing could occur. Figure 14b shows this scenario, where part of the trailer impacts the truck, potentially causing damage.

To avoid this situation, our product detects the changing angle (Figure 14c between the truck and trailer and moves the hitch connection point towards the inside of the turn. See Figure 14d.

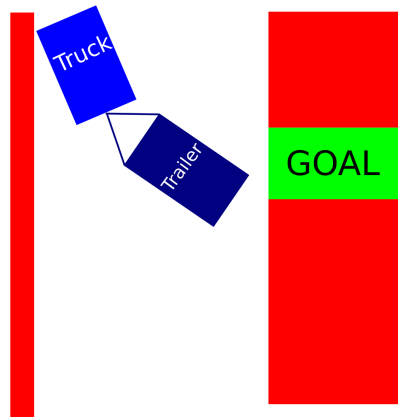

*Red = walls

(a) Tight trailer parking scenario

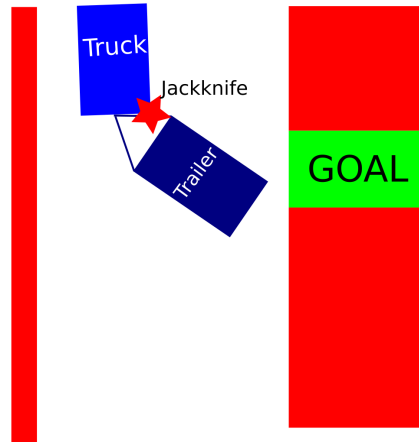

(b) Jackknifing condition

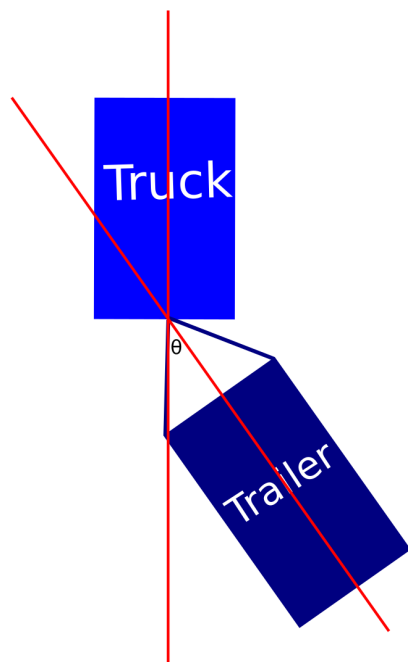

(c) Angle referred to as θ

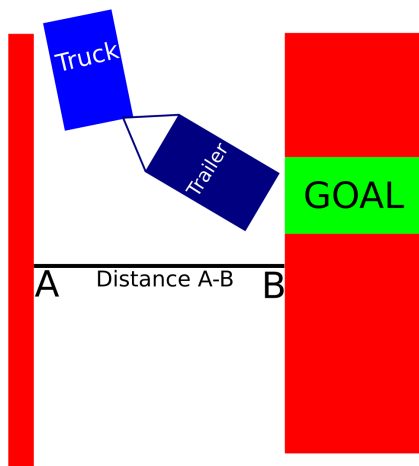

*Red = walls

(d) Moving attachment point decreases turning radius by allowing more extreme angle before jackknifing occurs.

Figure 14: Illustration of the Active Hitch Adapter's impact on trailer maneuverability and safety

The definition of turning radius can be ambiguous. For instance, does turning radius only include only the path of the rear tires of the trailer? Such a

definition would neglect overhang of the trailer, which might be the deciding factor between a successful turn and damaged equipment. For the purposes of this paper, we are only using turning radius as a comparative metric; the performance objective is to improve turning radius when the system is active versus when it is not. Because of that, it is useful to define a simpler metric which more directly gets to the heart of the utility of this device, which is in improving maneuverability. That metric is distance between the walls (labelled A-B in Figure 14d). One way to think about this is to consider a business which uses trailers to move some good. If that business normally parks their trailers in a row as shown in Figure 14d, the limiting factors on how long their trailers can be is this distance A-B (assuming all other factors such as type of trailer connection, truck length, etc. are held constant). A longer trailer could be more efficient from a business costs perspective, and therefore this product might be useful, as it allows a longer trailer to fit into the same size spot.

8.3.4 Mathematical Analysis (Sway Mitigation)

To more rigorously analyze the condition of a truck-trailer system in oscillation (sway), we can consider it to be a mechanically damped oscillator [30]. This is because the friction in the contact patches of the rear tires on the truck oppose the component of velocity perpendicular to the frame rails of the truck. Jingsheng Yu and Vladimir Vantsevich solved, in a 2021 book, this dynamics problem within the constraints of a bicycle model truck and trailer [30]. Isolating the damping ratio, we have:

$$\zeta = \frac{1}{2v} \sqrt{\frac{C_{\alpha t}}{M_t \frac{l_t^2}{(l_t+l_k)^3} + I_t \frac{1}{(l_t+l_k)^3}}$$

where the variables are parameters of the truck trailer system:

- Velocity (v)
- Tire slip angle (α_t)
- Lateral tire cornering stiffness ($C_{\alpha t}$)
- Distance hitch-trailer CG (l_t)
- Distance trailer CG - truck tire (l_k)
- Trailer mass (M_t)
- Tire force in lateral trailer wheel direction (F_{yt})

When this damping factor is overdamped (greater than 1), the trailer is sluggish behind the truck, causing difficulty turning and maneuvering. When it is underdamped (less than 1), however, oscillations can become uncontrolled. Both underdamped and overdamped conditions are oscillatory. Only a critically

damped system responds to disturbance (such as a pothole or a swerve) by returning the system to equilibrium in the fastest possible time. We have now arrived at the method behind our product’s trailer sway mitigation strategy; nudge the truck-trailer system (which we assume to be underdamped, if sway is occurring) more towards a critically damped condition by modifying some of the parameters that make up the damping ratio and thereby increasing it. Specifically, by moving the hitch attachment point laterally, we increase the lateral component of l_t , decrease l_k , and increase the magnitude (positive or negative) of α_t . F_h is decreased. v_t is also increased because the trailer tracks a longer arc at the same speed but we did not include it in any modeling. We estimate this is a small effect and may even be outweighed by the increased braking force exerted by the contact patch of the trailer tire increasing (because of sidewall flexing) as the trailer pivots.

To determine the scale of actuator necessary to significantly mitigate trailer sway, the trailer’s approximate size, moment of inertia, tire stiffness, and expected oscillation frequency were used to estimate the force required to critically damp the swaying trailer. The critical damping coefficient for a trailer in sway was calculated and then used to calculate the total torque required for critical damping. The trailer’s natural damping coefficient was then calculated and used to calculate the damping torque inherently exerted by a swaying trailer. The inherent damping torque was then subtracted from the critical damping torque to determine the additional torque needed for critical damping, which was then used to calculate the maximum lateral force on the hitch needed to critically damp the trailer. The Python code containing this computational process is shown in Figure 15. It was ultimately determined that critical damping of a typical small trailer could require over 1000 N of lateral force applied at the hitch. To verify this sentiment, the report by Sykora [13] was consulted as well. Though Sykora attempts to address sway in somewhat larger trailers than those of focus in this project, he states the force requirement to be around 3000 N. The key factor to consider is that ultimately, the most powerful actuator that could fit under our budget was less than 100 N. Between the 1000 N estimate for our scenario and the 3000 N estimate for the Sykora scenario, which had trailer dimensions on at least the same order of magnitude as ours, this analysis contributed to the decision not to focus physical development on mitigation of trailer sway. It is also worth noting that, while we did not perform our own estimate of required actuator speed, the Sykora paper stipulated a speed that, like the required force, would not have fit under our budget in the form of an electric linear actuator. Key assumptions and computed estimates are presented below.

- Assumptions

- trailer bed length: $l = 3m$
- trailer rear to hitch dist: $d = 4m$
- trailer mass: $m_t = 400kg$
- load mass: $m_l = 350kg$

- load placement: fully behind wheelbase
- sway frequency: $f = 0.714Hz$
- forward vehicular speed: $v = 25m/s$
- tire stiffness: $C_{\alpha t} = 48000Nm$

- Calculated Estimates

- max necessary lateral force: $F = 1160N$
- max natural damping coefficient: $c = 2945Ns/m$
- critical damping coefficient: $c_c = 6765Ns/m$

Figure 15: Python code for computing required damping force

```

import math
m_e = 400 # mass of empty trailer
m_l = 350 # mass of load
L_f = 1.8 # length from trailer axle to front of loadable space
L_b = 1.2 # length from trailer axle to trailer rear
L_h = 2.4 # length from trailer axle to hitch
l = L_f + L_b # total trailer frame length
w = 2 # width of trailer
f_0 = 0.714 # natural frequency of trailer sway
omega_0 = f_0 * 2 * math.pi # natural frequency of trailer sway in radians
arc_length = 0.3 # linear distance traveled by trailer hitch during sway
v_lin_max = arc_length * omega_0 # max linear velocity of trailer hitch during sway
v_ang_max = v_lin_max / (L_h) # max angular velocity of trailer in sway
v = 25 # speed of moving vehicle (about 55 mph)
L_h_cg = L # length from hitch to center of gravity
# assumed to be very rear of trailer to provide sway condition
L_wcg = L_b # length from wheelbase to center of gravity
stiffness = 48000 # tire stiffness, taken from textbook as typical value
m_tot = m_e + m_l # total trailer mass
m_f = m_e * L_f / L # mass in front of wheelbase (empty)
m_b = m_e * L_b / L # mass behind wheelbase (empty)
mFL = m_l * L_f / L # mass of load in front of wheelbase
mBL = m_l * L_b / L # mass of load behind wheelbase
I_e = (m_e * L_f ** 2) / 12 + m_e * L_f * L # forward component of empty inertia
I_b = (m_b * L_b ** 2) / 12 + m_b * L_b * L # rear component
I_empty = I_e + I_b # moment of inertia of empty trailer
I_full = I_empty + (mFL / 12) * (L_f ** 2 + 6 * L_f * L + 4 * L ** 2) + (mBL / 12) * (L_b ** 2 + 6 * L_b * L + 4 * L ** 2) # inertia of full trailer with even load distribution
# after load behind axle
mBL = m_l # mass of load behind wheelbase
mFL = 0 # mass of load in front
I_full = I_empty + (mFL / 12) * (L_f ** 2 + 6 * L_f * L + 4 * L ** 2) + (mBL / 12) * (L_b ** 2 + 6 * L_b * L + 4 * L ** 2) # inertia of full trailer with load fully behind wheelbase (inertia used for calc)
# (this is the condition that creates sway)
c_c = 2 * omega_0 * I_full # critical damping coefficient of full trailer
default_damping_ratio = 1 / (2 * v) * (math.sqrt(stiffness * (m_tot * (L_h * cg ** 2) / (L_h * cg * L_w * cg ** 3))) # damping ratio due to tire stiffness
c = default_damping_ratio * L_w * cg # damping coefficient due to tire stiffness
I_q = v_ang_max * v # damping torque exerted by trailer
Tq_needed = v_ang_max * c # total torque for critical damping
Tq = Tq_needed - Tq_0 # additional torque needed for critical damping
FL = Tq / L_h # lateral force needed for critical damping at max angular speed
FLO = Tq_needed / L_h # lateral force needed at 0 angular speed
# (if this is maximum required damping force because v=0 means trailer
# has no passive damping)
print("Force needed at peak ang v = " + str(FLO) + " N")
print("Force needed at 0 rad/s = " + str(FLO) + " N")
print("passive damping coefficient = " + str(c))
print("critical damping coefficient = " + str(c_c))
print("I_full = " + str(I_full) + " kgm^2")

```

8.3.5 Software

The simulation conducted showed that the best control system to implement was to push the actuator out to either end when it detects an angle change beyond 15 degrees. The general flowchart for this is shown in Figure 16. In order to implement this in software, there first needed to be a mechanism to determine what to run. Since the only thing actually implemented in software was the reversal assist algorithm, we needed to check for the switch for reversal assist being on and the trailer reverse lights being on. These were read through general purpose input / output (GPIO) pins on the MSP432.

Next, the angle needed to be read in. This was done through analog to digital converter (ADC) pins on the MSP432, which returns a 14 bit value, with the highest value corresponding to a 3.3V signal. With there being 16,384 14-bit numbers, and a range of 180 degrees from the sensor, each degree corresponds to a value of 91. This means that 15 degrees each way from the center is at

6,827 and 9,557. Every 10ms (100Hz), the sensor value was read in through the ADC, the GPIO pins were read in to determine if the routine should run or not, and the an output was created on a PWM pin with the duty cycle either set to 0%, 50% or 100% to push it to either extreme or keep it at the center based on the angle. The flow chart used is shown in Figure 16. A code listing of the runtime is shown in Figure 17.

Figure 16: Software flowchart for reverse runtime

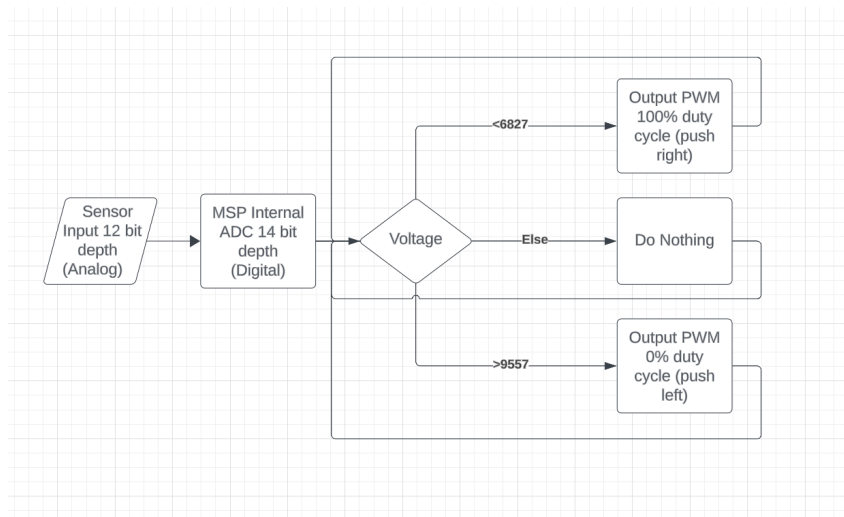

Figure 17: Code listing for reverse runtime

```
void ADC14_IRQHandler(void)
{
    uint16_t adcRaw = ADC14->MEM[0]; // read adc data
    uint16_t vcc = 16384;           // 3.3V

    //return early if switched off or not in reverse
    if (!reverse || !switchReverse) return;

    if (adcRaw > 9557) // Greater than 15 degrees
    {
        TIMER_A0->CCR[1] = (30 * 0) - 1; // push left
    }
    else if (adcRaw < 6827) // Less than 15 degrees
    {
        TIMER_A0->CCR[1] = (30 * 100) - 1; // push right
    }
    else {
        TIMER_A0->CCR[1] = (30 * 50) - 1; // push center
    }
}
```

When the 7 pin shows reverse lights enabled, the micro-controller operates in park assist mode. Otherwise, it will operate in sway mitigation mode. There are two slider switches on the board; one disables park assist mode (so that even when the truck is in reverse, it will operate as a normal hitch) and the other disables sway mitigation.

8.4 Test plans

Test plans as executed are listed below, categorized by design phase. The test plan is in three phases: hardware testing, software testing, and system testing. The plans for the hardware and software test phases were written in detail in advance; the hardware and software plans appear below as pre-planned; steps were not necessarily strictly followed, but the plan was treated as a guidelines, through which we did ultimately verify all intended aspects of the hardware and software plans with the exception of the sway software routine, which is still in progress. Originally, no test plan was explicitly written for the greater system, so the system-level test plan is presented in two sections: “Finished” and “In Progress.” The finished test plans are presented how they were carried out and the in-progress test plans are presented how we intend to carry them out. We intend to finish all verification before the scheduled demo in the week following the submission of this report.

8.4.1 Hardware Testing

1. Verify LAC board and actuator function
 - Connect USB cable to X5 and actuator
 - Connect 12V power supply (benchtop or car battery, etc.) to Positive (+) of LAC board.
 - Use LAC software to issue commands from a Laptop connected to the USB cable.
 - Download LAC driver at <https://www.actuonix.com/datasheets>
 - Download LAC Advanced configuration software and Visual C++
 - Ensure the entire range of stroke can be driven by the LAC board. Verify using a measuring tape. The stroke should be 300mm.
 - Test variance in functionality under different loads.
2. Verify that the angle sensor gives valid data
 - Connect voltmeter to angle sensor output and measure voltage for representations of different angles
 - Set angle to 0 deg. Measure manually to confirm. Sensor should read 0 V
 - Increase angle by set increment (5 deg?). Measure to confirm. Read sensor output and record
 - Repeat (3) for full angular range of motion, including negative angles (non 0 in opposite direction). For every angle, record sensor output
 - Set each angle a second time, measuring to confirm. For each angle, read sensor output. Compare each output to initial reading for same angle. Verify that outputs match. Map output voltages to corresponding angles
 - Verify that relationship between voltage and angle is as expected. If as expected, sensor outputs can be mapped continuously to range of angles
3. Verify that all inputs are processed correctly by
 - Input Header
 - Apply voltage to input 1
 - * Verify same voltage at P1-1, P1-2, Sensor input 1, and J1-8
 - Apply voltage to input 2
 - * Verify same voltage at P2-1 and P2-2
 - * With switch 1 and switch 2 both closed (activated), verify same voltage at MSP Left pins 1 and 19
 - * With switch 1 and 2 open, verify that MSP Left pins 1 and 19 are ground

- Apply voltage to pin 3
 - * Verify same voltage at P3-1, P3-2, and MSP Left pin 17 (if possible)
 - Verify that Input 4 is grounded, along with:
 - * P4-1, P4-2, Sensor input 2, and Sensor input 4
 - Sensor Header
 - (Input 1 already verified in (1))
 - (Input 2 verified in (1))
 - Apply voltage to input 3
 - * Verify same voltage at P5-1 and P5-2
 - * Verify expected voltage at J1-5 given values of R1(3K) and R2(3K)
 - (Input 4 verified in (1))
 - LAC Header
 - Apply voltage to input 1
 - * Verify same voltage at P7-1, P7-2, and MSP Left pin 14
 - * Verify ground at input 2
4. Verify that the Power PCB outputs the correct voltages for VA and VB (3.3V and 5V)
 - Apply 12 V power supply
 - Connect voltmeter to VA (PCB “Board Output” pin 2) (Should read 3.3 V)
 - Connect voltmeter to VB (Board Output pin 1) (Should read 5 V)
 5. Connect sensor to Signals board and test I/O
 - Connect sensor to signals board
 - Set angles in 5 deg increments over full range of motion
 - Measure voltage at all points specified in Step 2
 - Verify that for each angle, all voltages measured in (3) are equal and match the expected value according to mapping in Step 2

8.4.2 Software Testing

1. Angle detection verification
 - Physically alter hitch angle
 - Track variable representing hitch angle (voltage read from Hall-effect sensor)

- Measure angle physically and verify that it is correctly indicated by variable
2. Direction/velocity detection verification
 - Set breakpoints after each angle is written to memory to read memory and verify
 - Step through to write several angles to memory
 - verify that hitch direction and lateral velocity is correctly identified by tracking angle sequence
 3. Motor control verification
 - Input values for motor speed to ensure that actuator speed is successfully set by program
 - Input values for actuation in both directions to verify direction control
 4. Backup mode verification
 - Set breakpoint after designation of mode beginitemize
 - If V at pin7 = 12V, backup routine should be selected
 - Ensure that backup mode can be manually deactivated by flipping switch
 5. Backup routine
 - Set non-zero angle. Ensure that actuator responds in correct speed and direction
 - Set angle to zero. Ensure that actuator does not move
 6. Oscillation detection and reconstruction
 - Simulate sway by physically moving hitch back and forth
 - Verify that angular motion detection results in correctly identified oscillation
 - Verify that program is able to digitally reconstruct the harmonic signal of hitch motion
 7. Sway mode
 - If oscillation is detected, verify that sway mode is activated
 8. Sway routine
 - Verify that in sway mode, the digital representation of the hitch oscillation is processed correctly
 - Actuator should act in opposite direction of hitch motion during sway

- Force of actuator should be properly scaled (with a more powerful actuator, we would have to scale force to avoid overdamping, but because our actuator is underpowered, we will probably want to apply maximum force throughout sway)

8.4.3 System Testing

- Finished
 - Verified that, with PCBs, actuator, and sensor interconnected, actuator direction was controlled and as expected in response to angular input from the sensor
 - Verified that physical assembly of altered hitch could support the weight of a small trailer
 - Verified that the coupler-attaching component of the sensor mount could fasten securely to a hitch coupler
 - Verified compatibility between PCB enclosures and PCBs
 - Verified that actuator, fully integrated, could move hitch back and forth with no additional load given angular input from sensor
 - Verified that, given angular input, fully integrated actuator could move hitch back and forth with hitch mounted to a vehicle and a small trailer in tow
 - Compared turn radius using conventional hitch to radius using altered hitch
 - * Verified reduction in turn radius
- In Progress
 - Full integrated functionality of assembly
 - * Verify that hitch-attaching component of sensor mount can fasten securely to a hitch
 - * Verify that sensor is able to accurately detect truck-to-trailer angle with sensor mounted
 - * Fully mount system (PCBs, hitch, actuator, sensor) and verify correct actuation in response to truck-trailer angle

9 Timeline

An original plan for timeline of progress is shown in a Gantt chart format in Figures 18 and 19. Assignees are shown in the left column, and the tasks have been split into 7 categories: Papers and Presentations, Simulation, Physical Components, PCB, Embedded, Physical Structures, and System Testing. The Gantt chart was designed so that work could be done in parallel as much as possible. This can be seen in the fact that Simulation and Physical Component

design was slated to be done at the same time since these groups of tasks did not rely on one another. This is also done with Papers and Presentations and System testing throughout, as well as Embedded system design being slated in the same time frame as Physical Structure creation. Some parts, however, had to be done linearly, such as PCB design only possible after Physical Components had been selected and defined.

When assigning work, member's strengths were considered. Certain tasks required the help of everyone, such as Papers and Presentations and System Testing. Cole, with his experience in metal fabrication and PCB design was responsible for leading the Physical Structure and helping source Physical Components. John was responsible for PCB work and help with Physical Structures due to his previous experience with PCBs and 3D printing. Shrishra was responsible for Embedded and Simulation with his previous experience in software and computer applications. Finally, Taylor was responsible for Simulation and Embedded due to his previous experience with software and helped with PCB design. These strengths were based on each group member's past experiences and classes they had taken.

Figure 18: Original Gantt chart for Papers and Presentations, Simulation, Physical Components, and PCB

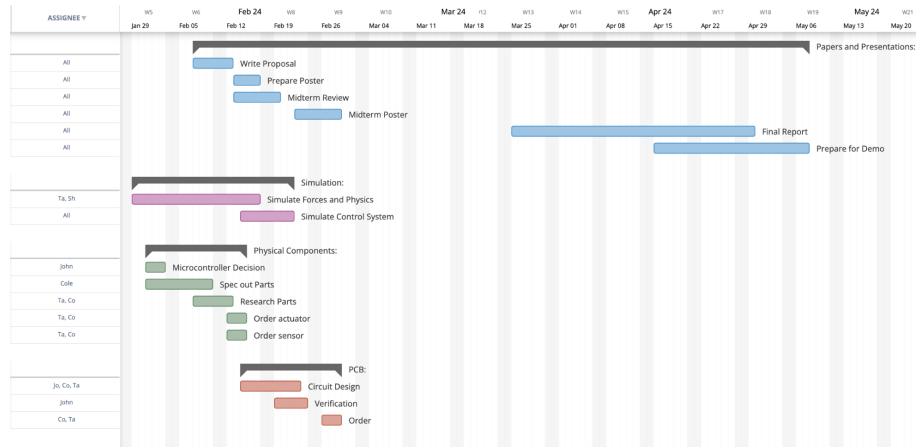
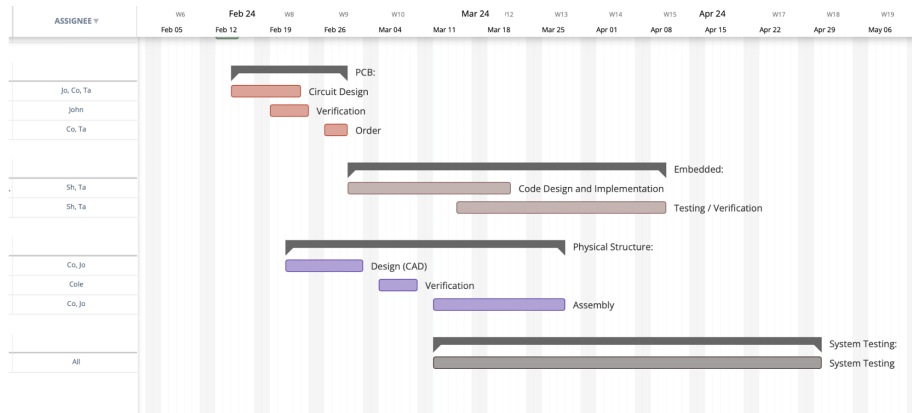

Figure 19: Original Gantt chart for PCB, Embedded, Physical Structure, and Testing



Figures 20 and 21 show an updated Gantt chart at the end of the project. Some differences can be seen when compared to the original. First, the tasks are more detailed, reflecting the variety of work that came up as the project progressed that was not foreseen at the beginning. This can best be seen in the Simulation section. Whereas in the original Gantt chart, there were two tasks, in the final Gantt chart, there are eight tasks. Second, some tasks got shifted around in the timeline. This was either because some tasks took longer than expected due to delays, or the fact that as the project progressed, priorities shifted, causing certain tasks to be pushed back. This was the case with the physical structure assembly, which got pushed back due to delays in PCB finalization and changing priorities caused by external deadlines. Deadlines were also generally shifted to finish on Wednesday.

One thing that remained similar to the original Gantt chart was each member's general responsibilities. John spent most of his time helping in the Physical Structure section and ended up taking some responsibilities in System Testing. Shrisha took lead of the Embedded software aspect and helped in the PCB section. Cole led the Physical Structure section and helped with PCB and Simulation. Taylor focused on PCB and Simulation. The original Gantt chart had a lot of buffer time built in and this time ended up being used by various hurdles that arose.

Figure 20: Final Gantt chart for Papers and Presentations, Simulation, and Physical Components

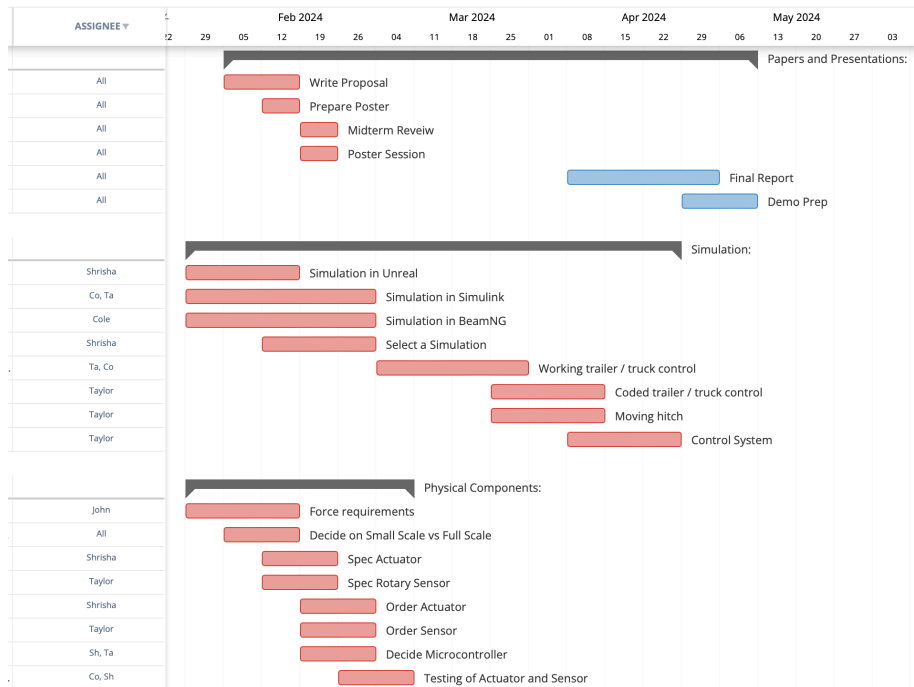
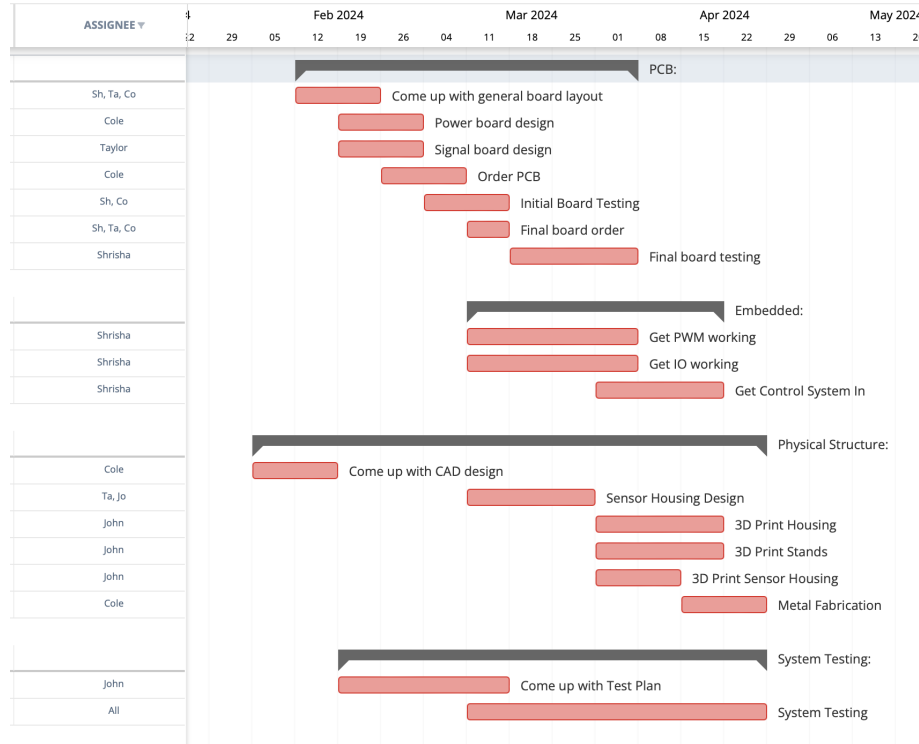

Figure 21: Final Gantt chart for PCB, Embedded, Physical Structure, and Testing



10 Costs

The total cost of creating the prototype presented in this paper was \$300.38. Table 3 shows a detailed breakdown of the components involved in the manufacturing of the prototype. It is important to note that the only things paid for when creating the prototype was the physical materials themselves, as manufacturing and assembly was conducted by the group members. Because of this, the cost of services was effectively zero. It is also important to note that certain components were available for free, such as some of the metal used to create the skeletal structure, the 3D printing filament, and the MSP microcontroller. One aspect that drives this price higher is the fact that all components were purchased in low quantities. If purchased in higher quantities and entering bulk purchasing breakpoints, the prices of many components would decrease significantly. Things that would not be included in a production product were also not included in price calculations. This included things like the AD3 header, jumper pins used for testing and debugging on the signals board, and op amp socket.

To understand what the price would look like when produced in bulk (10,000

units was used for this exercise), bulk pricing for all materials was used and manufacturing prices were estimated. These estimates are shown in Table 4, resulting in an expected cost of production of \$225.81 in bulk. There were some materials whose price is not truly reflected in bulk. For example, items such as the actuator, sensors, and control boards, all of which contributed significantly to the final prices, did not have price breakpoints beyond 100 units. If assembly on mass scale was taking place, deals could be made to bring down the price for 10,000 units, bringing the overall price down.

For raw material costs like steel and 3D printing filaments, bulk costs were used as a reference and multiplied by the required amounts to create one unit. Other materials that were purchased for the prototype could be assembled in house when producing in bulk, such as the hitch and ball. For this exercise, the price has been added into the raw metal material cost. Assembly costs are threefold: one for PCB assembly, one for metal assembly, and one for final system assembly. PCB assembly is offered for free at many manufacturers for large scale orders. Metal assembly is estimated to cost the same as the cost of raw steel itself, and final assembly is expected to cost \$1.50 with an hourly rate of \$30 and an optimized assembly time of 5 minutes [5] [4].

11 Final Results

In evaluating the success of our device, we divide our analysis into two primary objectives; our first objective was improving reversing maneuverability and our second was sway mitigation. For the first objective of aiding in maneuverability for revering was successful in both the simulation and real world. Simulations showed that our hitch gave reduced the turning radius of the trailer by 12% as shown in 22, which tracks the path of the truck (outer path) and trailer (inner path). To simulate the turn radius, we drove identical cars and trailers in a circle, with and without the hitch system engaged. While the turn radius of the car stayed relatively the same, the turn radius of the trailers was decreased substantially. This is significant because the trailer’s turn radius is the limiting factor when maneuvering the vehicle for example, into a parking spot.

Figure 22: Turn Radius With (Left) and Without(Right) Hitch System

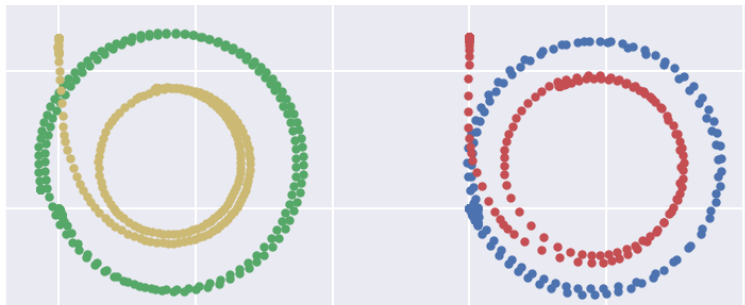

In the real world our goal of aiding in reversal was accomplished but only anecdotally. We ran into issues mounting the sensor to the truck and had to imitate the truck-trailer angle by manually moving the sensor. Additionally, the truck we rented did not have a hitch receiver so we had to resort to using a golf cart to pull our trailer. Since the golf cart did not have a 7-pin output, we had to substitute a 12V battery for the power supply. The hitch system would have been able to function off the 7-pin input were it available for the final testing, as verified by plugging the 7-pin into a U-Haul and the board powering up. Despite the difficulties faced when testing, the hitch system made it easier to reverse and manipulate the trailer into parking spaces with our reverse system engaged and the driver felt a clear difference. Unfortunately, we were not able to get the were able to numerically show a reduction in turning radius. We performed tests where we had the go-cart and trailer exit from a parking spot turning as hard left as possible. The driver continued turning until he was perpendicular with the parking spot. We measured the distance from the carts wheels to the back of the parking space and saw that our hitch gave us an additional six inches of clearance. It should also be noted that the hitch itself occupies distance between the trailer and truck so some of that distance improvement we saw was due to that.

For the second objective, of trailer sway, all of our results came from simulation due to the dangers of inducing trailer sway in the real world. The results from this are shown in Table 1 we found that moving the hitch when the yaw angle reached 15 degrees provided the best performance in maintaining straightness of the truck-trailer. This is likely because while triggering hitch movements earlier might save from larger oscillations, they likely to over correct, which induces a greater average angle throughout the simulation. Additionally, the simulation showed that it was better to adjust the hitch into the turn or direction it is already moving to create the angle between the truck and trailer. Similarly, timing the hitch so that the stroke took 1 second in and out seemed to be the most effective. These simulation results most hitch configurations are better than a static hitch that is never triggered.

For our real world testing of trailer sway, we were able to actively move the trailer to increase the yaw angle and see the hitch move the trailer in response. This shows that the system is responsive to changes in the truck-trailer angle and would up to sway in the real world as it does in the simulation. Unfortunately, as with the reverse testing, the sensor had to be moved manually and the system was not functional without that aid. We reason that ultimately passive dampeners might be preferable for reducing sway compared to the active system described in this paper. Active electro-mechanical systems necessarily introduce added complexity and failure modes. Additionally, the controls system would have to be versatile for all real world situations beyond those incorporated into the simulation. For example, the length or positioning of weight in the trailer would affect how we would ideally want our hitch to respond. If the timing of the hitch's movements are slightly off, it has the potential to worsen a sway condition.

We defined the project would earn an "A" if it Firstly "is able to effec-

Table 1: Trailer Sway Simulation Results

Trigger Angle	Adjustment Time	Towards Turn	Average Yaw	Max Yaw
0	0.5	Yes	7.68	25.90
3	0.5	Yes	5.61	27.36
5	0.5	Yes	4.32	30.07
10	0.5	Yes	4.84	24.98
15	0.5	Yes	4.39	16.01
20	0.5	Yes	5.23	20.15
120 (system off)	0.5	Yes	7.24	40.60
0	0.5	No	7.42	27.97
3	0.5	No	5.04	38.60
5	0.5	No	3.61	19.88
10	0.5	No	4.72	38.30
15	0.5	No	5.43	38.90
20	0.5	No	5.85	27.56
120 (system off)	0.5	No	4.89	18.23
10	0.5	Yes	4.44	26.94
15	0.5	Yes	4.65	15.85
10	1.0	Yes	4.06	25.96
15	1.0	Yes	4.38	17.63
10	1.5	Yes	3.97	27.11
15	1.5	Yes	66.35	177.25

tively decrease the turning angle when reversing by at least 10%, allowing for sharper corners and fitting the trailer in tighter spaces. The same is shown in physics simulations.” And Secondly, ”The adapter is also able to mitigate trailer sway, which is shown in physics simulation, but not in the real world due to safety concerns. Instead, movement of the adapter simulating trailer sway shows proper counteraction in order to mitigate trailer sway.” The hitch was successful in decreasing the turning radius by 12% in the simulation but was not proven numerically in our real world testing. Additionally, our simulations showed that trailer sway was reduced through our hitch attachment and algorithm. In physical testing we were able to show the proper response to a change in the truck-trailer angle. Detailed objectives for the entire system which we set at the beginning of the design process are listed below in 2. We did not have the time or resources to develop safety features or an automatic toggle switch between modes into the hitch system as we originally intended. While these were not our primary goals when we set out to create the device they would be essential in making it a viable product in the real world. Safety features such as an automatic shutoff and monitoring for over correction would improve the devices effectiveness and the safety for those in the vehicle. An algorithm to toggle between sway and reversal mode would make it practical for everyday use. We were focused on creating a functional prototype that proved our concept would be feasible in the real world.

Ultimately, our device was nonfunctional as a final product in the real world testing. Without the sensor being properly mounted or having the 7-pin power supply, there is no way of knowing how it would have performed as a final device. Functionality was shown through each step of its operation but not as a final unit. The hitch is able to draw power from the vehicle and distributing it to each component at the appropriate levels. It was able to read in the yaw data from the sensor and run an algorithm to determine how the linear actuator should react. The algorithm correctly determines how the hitch should move and the linear actuator is able to physically move the hitch position in real time, which moved the trailer. Through these steps, we were able to show that the hitch system, in theory, reduces trailer sway and makes the maneuverability in reverse easier, however we were not able to show that in practice.

12 Future Work

For future works iterating on this project, there are multiple lessons to be learned. The first is challenges with grounding, especially as it relates to multiple boards. Splitting up the electrics into two boards can introduce a difference in ground, leading to some electrical components becoming damaged. Although multiple boards lead to easier development and testing, it led to grounding issues that were only fixed upon shunting a direct connection to ground. For future works, it is recommended to keep the entire electrical portion on one board. Another difficulty was working with simulation software, which required a lot of time to setup and a lot of computing power to run. This slowed down development, so a powerful computer is recommended. Another pitfall to be wary of is the cost of major components. The actuator purchased for this project was a limiting factor, and more powerful components were priced starting at around 10 times the price [7]. The actuator used in this project, although priced lower, had low speeds, a low maximum force, and an inaccurate internal control system. For implementation of something like sway mitigation, where speed and exact positioning is necessary, a higher quality actuator (or, preferably, hydraulics) is needed. Finally, the voltage levels extracted from the 7-pin of the truck is not an ideal 12V and fluctuates from 13.5 - 14.5 volts when fully charged [29]. This is important to consider when designing circuitry to ensure no components are damaged.

From a mechanical perspective, our design did function for the prototype, but the only thing holding the trailer's tongue at the specified location is the plastic carriage and the ballscrew on the linear actuator. In violent sway, or even during normal driving, this is likely to break. Future work should incorporate a locking mechanism that is sturdier. The best option would be switching to hydraulics, which could lock the position of the trailer tongue with fluid pressure.

There are many possible avenues for improvement on this device, many of which could not be explored in this paper due to time and budget constraints. The first is to completely waterproof this device to IP standards [18]. This would allow for safe operation on the road during different weather conditions and can

be done by redesigning the housing of the electrical components. This was not explored due to budgetary concerns regarding the high cost of waterproof housings. Another method of improvement would be a larger, more powerful actuator. This would allow for a larger range of motion, opening potential for control systems that allow better maneuverability and sway mitigation. This could also connect to larger trailers with a 7-pin attachment, leading to a larger range of use-cases. This would especially be useful in cases such as semi-trucks, which, due to their increased length, have an even more difficult time maneuvering and making shallow turns. Creating an attachment with enough power to move the hitch point on larger trucks would make navigating in cities, narrow roads, and parking bays easier.

Future work can also investigate the effectiveness of sway mitigation in real life, something that was not explored in this work due to safety concerns. For further control of the actuator position, a 2-dimension plane can be added by combining two actuators, one for each direction. This extra dimension would allow for further control of hitch connection positioning, opening the potential for better control systems. Finally, a more friendly user interface can be integrated, potentially connecting to the CAN bus on cars that allow for data and controls to be shown on a screen from the driver's seat.

13 References

References

- [1] en. URL: <https://www.bosch-mobility.com/en/solutions/driving-safety/trailer-safety-control/>.
- [2] Johannes Dipl.-Ing. Gubernath (Fh). *Sway damper*. EP1038744A1. Dec. 4, 2002.
- [3] Fereydoun Aghazadeh and Arunn Pisharody. "Analysis of Accidents in Trailer Towing". In: *Advances in Safety Management and Human Factors* (2019), p. 240.
- [4] *Average Hourly Earnings of All Employees, M*. <https://fred.stlouisfed.org/series/CES3000000003>. [Accessed 27-04-2024].
- [5] *Construction Costs — American Institute of Steel Construction*. <https://www.aisc.org/why-steel/resources/construction-costs/>. [Accessed 27-04-2024].
- [6] Deltron Precision Inc. *Four Types of Linear Actuators: Mechanical/Electro Mechanical, Hydraulic, Pneumatic and Piezoelectric*. URL: <https://deltron.com/Linear-Actuators.html> (visited on 04/29/2024).
- [7] Digikey. *ELGC-BS-KF-32-300-8P*. <https://www.digikey.com/en/products/detail/festo-corporation/ELGC-BS-KF-32-300-8P/13976790>. [Accessed 27-04-2024].

- [8] Henrico County Police Division and D. A. Middleton. *Utility Trailer Compliance*. <https://henrico.us/assets/UtilityTrailerCompliance2010.pdf>. [Accessed 30-04-2024]. 2014.
- [9] Virginia DMV. *Virginia's Size, Weight, and Equipment Requirements for Trucks, Trailers, and Towed Vehicles*. <https://www.dmv.virginia.gov/sites/default/files/forms/dmv109.pdf>. [Accessed 30-04-2024].
- [10] DrawTite. *DRAW-TITE — 63300 — Trailer Hitch Alignment System, Backup Guide*. https://www.draw-tite.com/Product/63300_trailer-hitch-alignment-system. [Accessed 27-04-2024].
- [11] Alex Ellin and Gregor Dolsak. “The design and application of rotary encoders”. en. In: *Sensor Review* 28.2 (Mar. 2008). Ed. by John Billingsley, pp. 150–158. ISSN: 0260-2288. DOI: 10.1108/02602280810856723. URL: <https://www.emerald.com/insight/content/doi/10.1108/02602280810856723/full/html>.
- [12] Equal-i-zer. *Everything You Need to Know About Trailer Sway Control*. <https://www.equalizerhitch.com/blog/everything-you-need-to-know-about-sway-control>. [Accessed 27-04-2024]. 2019.
- [13] Connor Fry Sykora. “Trailer sway control using an active hitch”. MA thesis. University of Waterloo, 2017.
- [14] Michael G Gilbert, Daniel A Godrick, and Richard H Klein. “The effect of longitudinal center of gravity position on the sway stability of a small cargo trailer”. In: *ASME International Mechanical Engineering Congress and Exposition*. Vol. 48777. 2008, pp. 295–305.
- [15] Michael G. Gilbert, Daniel A. Godrick, and Richard H. Klein. “The Effect of Longitudinal Center of Gravity Position on the Sway Stability of a Small Cargo Trailer”. In: *Volume 16: Safety Engineering, Risk Analysis and Reliability Methods*. Boston, Massachusetts, USA: ASMEDC, Jan. 2008, pp. 295–305. ISBN: 9780791848777. DOI: 10.1115/IMECE2008-66022. URL: <https://asmedigitalcollection.asme.org/IMECE/proceedings/IMECE2008/48777/295/336911>.
- [16] Mfg Hammond. *Diecast Aluminum Enclosures (1590 Series)*. Hammond Mfg. Accessed: 2024-04-29. 2024. URL: <https://www.hamfmg.com/electronics/small-case/diecast/1590>.
- [17] Hiwin. *Linear Guideway*. Hiwin. Accessed: 2024-04-29. n.d. URL: [https://www.hiwin.tw/download/tech_doc/gw/Linear_Guideway-\(E\).pdf](https://www.hiwin.tw/download/tech_doc/gw/Linear_Guideway-(E).pdf).
- [18] *Ingress Protection (IP) ratings*. <https://www.iec.ch/ip-ratings>. [Accessed 27-04-2024].
- [19] IPC. *IPC-2221A: Generic Standard on Printed Board Design*. <https://www.ipc.org/TOC/IPC-2221A.pdf>. [Accessed 30-04-2024]. 2003.
- [20] ISO. *ISO 3732:2003*. <https://www.iso.org/standard/30210.html>. [Accessed 30-04-2024]. 2003.

- [21] Sara Jensen. “Understanding When to Use Hydraulics”. In: *Power & Motion* (Nov. 2022). URL: <https://www.powermotiontech.com/hydraulics/article/21254743/understanding-when-to-use-hydraulics>.
- [22] Craig A. KaplenskiTerry D. Marshall. *Trailer hitch with multi-directional dampening system and spherical rod-end assembly*. US6746037B1. June 8, 2004.
- [23] Martin H Mathisen. *Sway control means for trailers*. US3294421A. Dec. 27, 1966.
- [24] *Mini-Fit Connectors from Molex: The Industry’s Most Versatile Power Connector*. Digikey. URL: <https://www.digikey.com/en/product-highlight/m/molex/mini-fit-family>.
- [25] National Fluid Power Association. *NFPA - What Is Hydraulics*. Online. <https://web.nfpa.com/fluidpower/whatishydraulics.aspx>. Accessed 28 Apr. 2024.
- [26] Virginia’s Legislative Information System. “Title 46.2. motor vehicles,” § 46.2-1118. *Connection between vehicles; tow trucks towing vehicles by means of a wheel lift apparatus*. <https://law.lis.virginia.gov/vacode/title46.2/chapter10/section46.2-1118/>. [Accessed 30-04-2024].
- [27] Virginia’s Legislative Information System. *Chapter 10. Motor Vehicle and Equipment Safety*. <https://law.lis.virginia.gov/vacodefull/title46.2/chapter10/>. [Accessed 30-04-2024]. 2023.
- [28] TowGo. *TowGo® Trailer Backup Navigation Aid™ (U.S.A. and Canada)*. <https://towgo.com/products/towgo-sup-reg-sup-trailer-backup-navigation-aid-for-nbsp-u-s-a-nbsp-and-canada>. [Accessed 27-04-2024].
- [29] *What Is Car Battery Voltage? — Jiffy Lube*. <https://www.jiffylube.com/resource-center/car-battery-voltage#>. [Accessed 27-04-2024].
- [30] Jingsheng Yu and Vladimir Vantsevich. *Control Applications of Vehicle Dynamics*. CRC Press, 2021. URL: <https://doi.org/10.1201/9781003134305>.

A Budget Outline

Table 3: Cost of producing prototype (single)

Item name	Manufacturer ID	Cost
4 input Molex Header	43045-0400	\$6.04
6 input Molex Header	43045-0602	\$3.21
2 input Molex Header	43650-0228	\$2.20
Fuse	0473003.YRT1L	\$8.16
680uF capacitor	"860010475015"	\$1.35
100uF capacitor	UPW1V101MPD	\$1.17
Rectifier	1N5820	\$1.74
3.3V switching regulator	LM2576T-3.3/NOPB	\$7.16
5V switching regulator	LM2576HVT-5.0/NOPB	\$6.77
1uH inductor	2300LL-102-V-RC	\$15.84
6 pin molex wire	214755-1061	\$2.93
4 pin molex wire	214755-2043	\$12.48
2 pin molex wire	2147501023	\$3.65
Microfit Crimpt Molex	430300001	\$2.47
AD3 header	PPPC152LJBN-RC	\$2.25
0.001uF Capacitor	C322C103M5R5TA	\$1.44
2x10 header for msp	DW-10-10-T-D-452	\$5.18
Op-Amp	TLV272IP	\$1.24
Op-Amp Socket	A120347-ND	\$0.20
Switches	EG1218	\$1.52
3.3k resistor	CFR-12JR-52-3K3	\$0.20
52k resistor	CFR-12JR-52-1K	\$0.10
100k resistor	CFR-25JB-52-100K	\$0.10
0.0001uF capacitor	399-9839-ND	\$0.44
PCB	N/A	\$4.00
Actuator	T16-300-64-12-P	\$90.00
Actuator Control Board	LAC	\$30.00
Hall Effect Sensor	PS2P-CON-CE-M001-1A0-C0007-ERA180-05	\$55.56
Raw Steel	N/A	\$0.00
MSP	MSP430FR2032IPMR	\$0.00
3D Prints	N/A	\$0.00
7 Pin to 4 Pin adapter	TKUA1702	\$12.99
Hitch and ball	HPDMC	\$19.99
Labor	N/A	\$0.00
Total		\$300.38

Table 4: Cost of producing prototype (bulk)

Item name	Manufacturer ID	Cost (\$)
4 input Molex Header	43045-0400	3
6 input Molex Header	43045-0602	1.67
2 input Molex Header	43650-0228	1.02
Fuse	0473003.YRT1L	3.68
680uF capacitor	"860010475015"	0.78
100uF capacitor	UPW1V101MPD	0.27
Rectifier	1N5820	0.57
3.3V switching regulator	LM2576T-3.3/NOPB	3.46
5V switching regulator	LM2576HVT-5.0/NOPB	3.69
1uH inductor	2300LL-102-V-RC	8.07
6 pin molex wire	214755-1061	2.32
4 pin molex wire	214755-2043	6.74
2 pin molex wire	2147501023	1.9
Microfit Crimpt Molex	430300001	0.91
AD3 header	PPPC152LJBN-RC	0
0.001uF Capacitor	C322C103M5R5TA	0.34
2x10 header for msp	DW-10-10-T-D-452	5.18
Op-Amp	TLV272IP	0.5
Op-Amp Socket	A120347-ND	0
Switches	EG1218	0.8
3.3k resistor	CFR-12JR-52-3K3	0.02
52k resistor	CFR-12JR-52-1K	0.01
100k resistor	CFR-25JB-52-100K	0.01
0.0001uF capacitor	399-9839-ND	0.1
PCB	N/A	0.88
Actuator	T16-300-64-12-P	60
Actuator Control Board	LAC	23
Hall Effect Sensor	PS2P-CON-CE-M001-1A0-C0007-ERA180-05	42.4
Raw Steel	N/A	17.81
MSP	MSP430FR2032IPMR	0.87
3D Prints	N/A	3.51
7 Pin to 4 Pin adapter	TKUA1702	12.99
Steel Labor	N/A	17.81
Final Assembly Labor	N/A	1.5
Total		225.81

Table 2: Objectives Accomplished

Objective	Accomplished
The product should be capable of improving the ability of a driver to position the trailer in a given space while reversing (primary) and also capable of reducing sway (as defined as an under damped periodic deviation in truck-trailer angle) while driving forward (secondary).cl	Yes Primary, Undetermined Secondary
Actuator is responsive and capable of exerting appropriate force to counteract trailer sway effectively.	Yes, in Simulation
Safety mechanisms are integrated to prevent over correction or interference with normal driving	No
The device should be compatible with a wide range of truck and trailer configurations commonly found in the market.	Yes
The product does not require any connection (such as to an external battery or otherwise) beyond the 2" hitch receiver and a standard 7-pin connector.	Yes
It should also be capable of exposing, in real-time and unaffected by the adaptive hitch's movements, the 4-pin interface	Yes
The same safety features (such as chains and rapid disconnects) must be available with the product installed.	Yes
The product should function without input from the driver.	No in real world
The product should be toggleable, functioning as a regular hitch if deactivated.	Yes
The secondary objective should be toggleable independent of the primary objective.	No