

HEDGE
Hypersonic ReEntry Deployable Glider Experiment
Critical Design

A Technical Report submitted to the Department of Mechanical and Aerospace Engineering

Presented to the Faculty of the School of Engineering and Applied Science

University of Virginia • Charlottesville, Virginia

In Partial Fulfillment of the Requirements for the Degree

Bachelor of Science, School of Engineering

April 12, 2023

Team Members:

Joseph Abbe	Dick Doyle	Samuel Kristy	Matthew Quiram
Hussain Asaad	Grant Duemmel	Joseph Lee	Kaiya Saunders
Danielle Ashbahian	Daniel Fisher	Aaron Liu	Jackson Stoner
Joseph Beasley	Avery Goldberg	Hong Ji Liu	Nicholas Storey
Zachary Carroll	Nicholas Haddad	Lauren Murphy	Lucas Talbert
Aidan Case	Spencer Harris	Corin Myers	Thomas Yin
Andrew Culbertson	Sean Jones	Kevin Nguyen	Mateo Nguyen

On my honor as a University Student, I have neither given nor received unauthorized aid on this assignment as defined by the Honor Guidelines for Thesis-Related Assignments

ADVISOR

Christopher Goyne, Department of Mechanical and Aerospace Engineering

Table of Contents

Project Overview	2
Mission Statement	3
Mission Objectives	3
Alignment with NASA and DOD Mission and Goals	3
Mission Architecture and Concept	4
Design Requirements and Constraints	6
Communications	6
Software and Avionics	8
Attitude Determination and Control Systems and Orbits	12
Power, Thermal, Environment	15
Structures and Integration	18
Management, Team Roles and Responsibilities, Meeting, Collaborations, Reporting and Reviews	22
Schedule	23
Cost	25
Conclusion	26
References	27
Appendices	28

Project Overview

Hypersonic technology is increasingly being invested in by the US government and private sector. (Cooper, 2022) This field of research and development has both civilian and military applications, with military applications being a short term goal. For the military, hypersonic weapons have a unique combination of speed and maneuverability that make them difficult to defend against. On the civilian side, applications include advanced, high-speed air travel and space exploration. A CubeSat, a small satellite that can be launched relatively inexpensively and designed with many commercial off the shelf parts, can be used for undergraduate education. This team of undergraduates will use a CubeSat to perform a hypersonic glider flight experiment. Hypersonic flight experiments are usually expensive to perform on rockets and difficult to replicate with a wind tunnel or numerical simulation. By using a CubeSat, university students can conduct these experiments at a lower cost, and with greater accessibility than traditional means.

The Hypersonic ReEntry Glide Vehicle project, or HEDGE, is a proof of concept mission determining the feasibility of using CubeSats as a means of low cost sustained hypersonic flight. Created and designed by University of Virginia aerospace engineering undergraduates, HEDGE will demonstrate the ability for undergraduate students to perform hypersonic experiments at lower cost and with greater accessibility than traditional programs. Currently, HEDGE is undergoing the critical design review step of NASA's project life cycle. The critical design review determines if the system design is mature enough to proceed with full-scale fabrication, assembly, integration and test (NASA, 2007). In other words, to pass the critical design review the design must be almost completely completed and feasible enough to proceed with fabrication. This document begins with the general project overview and mission statement. Below are the objectives, both primary and secondary, outlined by the project's program management team from the initial year. Continuing on, the regulations set forth by NASA and the government are explained, followed by the specifications set in order to send up a vehicle into space, ending with each functional group's plan and research. This document then concludes with a description of the management and schedule as well as the cost for the entire project.

Mission Statement

The purpose of this mission is to demonstrate the feasibility of using CubeSats in low cost hypersonic glider flight experiments.

Mission Objectives

The mission has five objectives, three primary and two secondary. The primary objectives define the "broad goals the system must achieve to be productive" while the secondary objectives are often non technical and address social, political, or cultural concerns. For our mission the secondary objectives focus on non-technical goals of educating undergraduates and promoting engineering in the community (Wertz, Everett and Puschall, 2011). These less technical secondary objectives are equally important for the mission to be a social or political success in the eyes of the University of Virginia and the DOD or NASA. Table 1 outlines the primary and secondary mission objectives.

Primary Mission Objectives	
O1	Demonstrate the feasibility of affordable CubeSats as a platform for hypersonic glider

	flight research.
O2	Demonstrate a materials screening method for hypersonic flight conditions at an extremely low cost.
O3	Show that undergraduate students can conduct hypersonic glider flight experiments at lower cost and with greater accessibility than traditional programs.
Secondary Mission Objectives	
O4	Integrate undergraduates into an industry, government, and university partnership involving complex systems engineering and program management with multiple stakeholders.
O5	Conduct STEM and hypersonics outreach to community and potential engineering students.

Table 1: Primary and Secondary Mission Objectives

Alignment with NASA and DOD Mission and Goals

Developing hypersonic technologies is continuously becoming more important for the United States. The DOD budget for hypersonic research has increased by almost 20 percent from fiscal year (FY) 2022 to FY 2023, a much larger increase than the overall DOD budget increase. Hypersonic technologies have multiple military applications from boost glide vehicles to scramjet powered cruise missiles. They offer a unique combination of speed and maneuverability, making it incredibly difficult to counter. The DOD has set a goal, through the program Multiservice Advanced Capability Hypersonic Test Bed (MACH-TB), to conduct at least one hypersonic test per week (Cooper, 2022).

NASA has researched hypersonic technology for over 50 years with the short term goal of assisting DOD research to support national hypersonic capabilities, and the long term goal of low cost reusable hypersonic air breathing space access (Dryer, 2017). HEDGE offers the ability for real world hypersonic testing at an extremely low cost that can assist with the DOD and NASA’s short and long term goals.

Mission Architecture and Concept

Defined by James Wertz, David Everett, and Jeffrey Puschell (2011), every space mission contains eight elements that, when combined, define the space mission architecture. The definitions of each element are defined in Appendix A. The elements of this hypersonic mission are detailed below. The mission concept, defined as “how the mission elements work together to meet the needs of the end user”, is listed below the space mission architecture.

Mission Architecture

1. Subject
 - a. HEDGE will interact with the atmosphere in extreme low earth orbit (ELEO) and collect material performance data, flow data (temperature and pressure), and glider orientation.
2. Payload

- a. The payload consists of four thermocouples measuring temperature on four material panels, and four pressure transducers on each side of the nose cone measuring pressure.
3. Spacecraft Bus
 - a. The spacecraft will fit into a 3U CubeSat deployer. After being deployed, it will unfold its fin plates to form a reentry vehicle.
 - b. In its folded 3U position (launch position), from back to front, there will be a 1U section containing the electronics, then there is a 2U section with the fin plates folded over the nose cone.
 - c. In its deployed reentry position, from back to front, there will be a 1U section with the fin plates unfolded, another 1U section with the fin plates unfolded over the electronics section. Next, there will be a 2U section with the nose cone uncovered.
 - d. The spacecraft will have an electronics suite to support the payload as well as solar panels on the fin plates to supplement the battery health.
 - e. See figure 1 below for a 3d labeled model of the CubeSat.
4. Ground Segment
 - a. HEDGE will relay data to the Iridium satellite constellation that will be accessible on the ground via the internet.
5. Mission Operations
 - a. HEDGE will autonomously operate from mission launch to burn up during reentry, allowing data to be collected via the internet.
 - b. Launch will occur in ELEO approximately at 215 km on the second stage of the Antares 330 or a similar rocket. After deployment from the launch provider, it will remain off for 30 minutes after which mission operations will autonomously begin.
 - c. The spacecraft will orbit for no more than 16 days before reentry. Upon reentry, hypersonic data will be collected for approximately 10 minutes. After data collection, the spacecraft will burn up in the atmosphere.
6. Command, Control, and Communications Architecture
 - a. The spacecraft will autonomously operate, collecting and relaying data to the Iridium network to be downloaded by the ground team.
7. Orbit
 - a. The spacecraft will launch at roughly 215 km and orbit for approximately 16 days before beginning reentry and data collection.
8. Launch Segment
 - a. The spacecraft will be launched from the second stage of the Northrop-Grumman Antares rocket at ELEO.

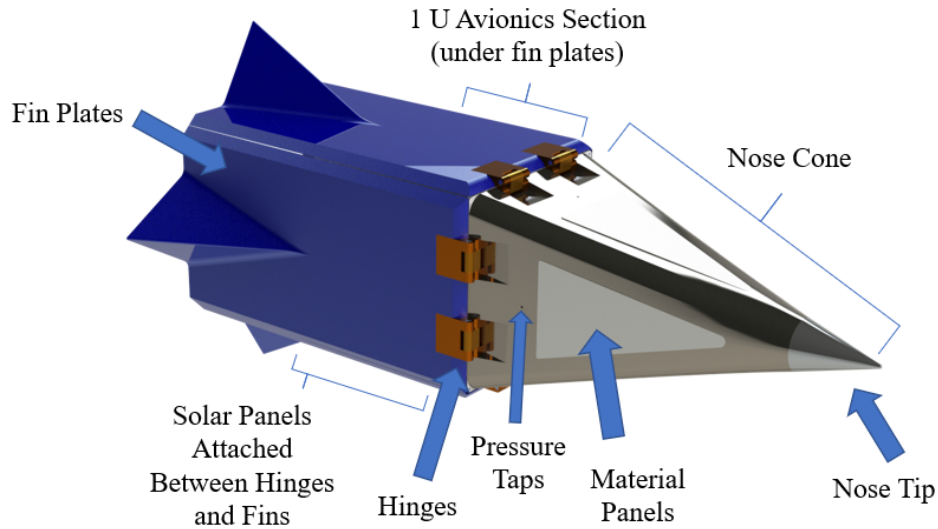

Figure 1: Labeled CAD model of HEDGE in the deployed unfolded state

Mission Concept

HEDGE will be launched from the second stage of the launch rocket at approximately 215 km. 30 minutes after deployment, it will autonomously turn on and begin operations. The fin plates will deploy automatically via torsion springs. Through the use of solar panels and onboard battery, the spacecraft will remain powered for up to 16 days until reentry begins due to natural deorbiting. During hypersonic reentry, temperature and pressure data will be collected and uploaded to the Iridium satellite constellation. One major challenge is relaying data back to earth during hypersonic reentry due to the plasma-sheath present at hypersonic speeds. By sending data backward up into space to the Iridium constellation the data will not be blocked by the plasma-sheath. After approximately 13 minutes of hypersonic data collection, the spacecraft will completely burn up in the atmosphere. See Appendix B for the mission concept graphic. The end users include the MAE 4700 Spacecraft Engineering students at the University of Virginia, the University of Virginia School of Engineering and Applied Sciences, the launch provider and funder, and the hypersonics research community.

Design Requirements and Constraints

As laid out by Wertz, Everett and Puschall (2011), from the objectives, requirements and constraints must be formed to “establish the operational concepts” of the mission. These requirements and constraints help the design team to go from the high level objectives into more technical guidelines to ensure the design is meeting the objectives. The mission has two types of requirements, functional and operational. Functional requirements define “how well the system must perform to meet the objectives”, while the operation requirements “determine how a system operates and how users interact with it”. The constraints “limit cost, schedule, and implementation techniques” to provide limitations for the design. Together the objectives, requirements, and constraints provide the framework for functional team design requirements. Appendix C contains the functional requirements, operational requirements, and the constraints. The next sections will outline the subsystem specific design information in the following order: communications, software and avionics, attitude determination, control systems and orbits (ADACS), Power, Thermal and Environment, and finally structures and integration.

Communications

Subsystem Design Requirements

For the Communications subsystem there are seven main requirements, each of these aligning with one or more of the system level functional requirements, system level operational requirements, and system level constraints. First, the communications system needs to be able to transmit data to a satellite constellation and to a ground station, all through automated data transmission. Additionally, during re-entry, the system must transmit data every 10 seconds and every hour while in orbit. Next, the components selected need to be cost-effective by being under \$1000 as well as lightweight being under 22g. Furthermore, it is required that the transceiver and antenna selected are compatible with the satellite constellation and can withstand the re-entry environment. Lastly, FCC and federal regulations need to be followed (see Appendix D for full details).

Summary of Major Elements

The major elements that compose the communications systems of the HEDGE CubeSat include a transceiver, relay satellites, ground station, and antenna. The transceiver acts as both a transmitter and receiver in one. The transmitter component sends radio frequency (RF) signals in the form of electromagnetic waves to relay satellites. Relay satellites are essential components that provide continuous contact with a satellite in orbit by eliminating the need for the CubeSat to be directly over a ground station. Many of these satellites orbiting the Earth in LEO provide non-stop communication with the HEDGE CubeSat when in the form of a constellation. The data that is transmitted to these relay satellites can then be immediately transmitted down to the ground station with low latency. The ground station acts as the data collection hub on Earth for later analysis. In the case for Hedge, the ground station is simply the personal computer that possesses the code for the data collection. The receiver component of the transceiver is used to obtain commands from the ground station again through the use of an inter-satellite link referred to as the relay satellites. A modulator is a major subcomponent of the transceiver as it encodes collected data into RF waves to be transmitted and decodes received commands through the form of RF waves into useful data. The antenna is used only for receiving and sending the RF waves through space between the CubeSat and relay satellites. Antennas can come in many forms, but one that is commonly used for CubeSats are passive patch antennas in which they are semi-directional and require no power.

Selected Components and Justification

The transceiver chosen for the HEDGE CubeSat is the Iridium 9603 Transceiver. Compared to other possible transceivers, this one is relatively cheap, coming in at about 200 dollars. It is also a lightweight and small option that is fitting for the mission: a space-constrained satellite. The radio also has a frequency range of 1.616 to 1.627 GHz which makes it an L-band transceiver. This is ideal as it allows for temporary plasma-sheath penetration, as well as being compatible with the Iridium satellite constellation. It is also compatible with the Short Burst Data (SBD) system Iridium utilizes. Compared to other radios with similar uses, Iridium 9603 has a larger range of operating temperatures, which is ideal for space and reentry conditions, and it has a lower power consumption level. The data transmission rate is also high enough to meet mission requirements.

The antenna chosen for the mission is the Taoglas IP.1621.25.4.A.02. This is a 4mm thick ceramic patch antenna. The antenna is also a very small, lightweight, and cheap option, making it

ideal for the space mission. Also, the frequency range, polarization, and operating temperature all coincide with the transceiver. The antenna is moderately directional, which allows for adequate gain and antenna strength, ensuring that the signal will reach the relay satellites, yet it still has a large enough beamwidth that a slight tumbling will not affect the radio waves ability to reach the satellites.

The relay satellite network chosen is the Iridium satellite constellation. The main advantage gained from this is that it has 100% global coverage. Considering the precise location of reentry is unknown, this was crucial. Additionally, the service subscription is cheap but still allows for ample data to be transmitted as per the mission objectives. It costs 35 dollars per month, and only one month is necessary for the mission. Charts displaying data on each component can be found in Appendix E.

Data Rate Determination

To determine the data transmission rate required based on the functional goals of the communications team, an analysis was performed. To begin it was determined that onboard the spacecraft, 4 thermocouples and 4 pressure transducers would be providing readings during the mission life of the spacecraft. Not expecting temperature or pressure measurements to exceed the integer 65535, it was determined that each measurement would be 2 bytes. With a desire to take 4 measurements per second, the data rate per sensor would be 8 bytes per second. Therefore, the entire sensor array would be collecting 64 bytes of data per second. Based on the communications functional goals, data will be transmitted once every 10 seconds. This then comes to 0.64 kbytes of data being transmitted every 10 seconds or 3.84 kbytes every minute. At a data collection period of 13 minutes based on reentry and burn up time, we are expecting a total of 49.92 kbytes of data transmission during reentry. Additionally, one measurement per sensor will be transmitted once an hour while in orbit (3 kbytes), for a total of 53 kbytes transmitted (over a period of 16 days). This is consistent with Iridium short burst data mode.

Transmission Coverage and Beam Width Determination

To ensure 100 percent transmission coverage with the Iridium tracking and data relay satellites, the required beam width of the patch antenna was determined. As shown in figure 2 a spacecraft altitude of 80km and relay satellite altitude of 780 km would require a beam width of 130 to 140 degrees. For the patch antenna used on this spacecraft, and as shown in figure 2 the beam width at 3dbi is 65 degrees. However, as this antenna is directional, the beam width at 1.5 dbi is 130 degrees, which could provide the mission with around a 100% transmission coverage. (Distance between satellites was determined using Iridiums live satellite tracker coordinates and NOAA coordinate to distance calculator.)

Details of subsystem assembly

In order for the communications system to work, the Iridium 9603 Transceiver needs to be connected to the motherboard and antenna. For the prototype, the RockBLOCK 9603 will be used which has the Iridium 9603 transceiver and a patch antenna integrated. The RockBLOCK 9603 will then be connected to the Raspberry Pi via a 10 pin Molex-style cable.

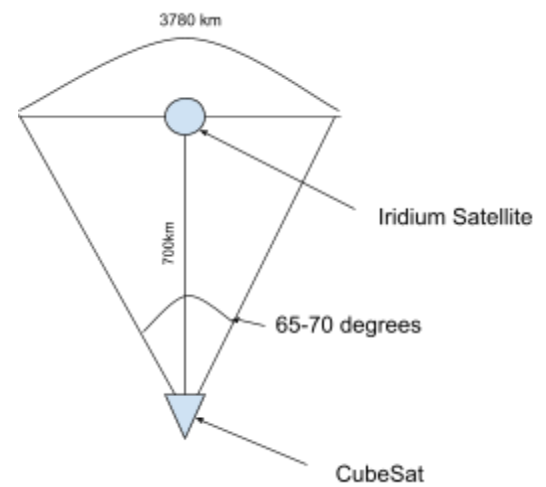

Figure 2: Satellite transmission coverage

Connecting to the Raspberry Pi will allow the transceiver to receive commands and acquire power. For the in-flight mission, the Taoglas IP.1621.25.4.A.02 patch antenna will be attached to a pcb board with an integrated ground plane along with a U.fl cable that is connected to the transceiver. The Iridium 9603 Transceiver is equipped with a Samtec low-profile header connector that attaches to a Samtec header female socket which allows for the transceiver to be soldered to a pcb that will connect to the in-flight on board computer.

Software and Avionics

Subsystem Design Requirements

The Software and Avionics subsystem consists of five design requirements for a successful mission. The first requirement is for all electronics to have a form of radiation protection alongside having flight heritage. Exposing electronics to certain radiations leads to failure. These radiations are found commonly in space. Without any protection, the electronics inside the CubeSat would malfunction, making data collection and processing unfeasible. Another essential part of the requirement is having electronics with flight heritage. The definition of flight heritage is having a history of successful usage in space or having gone through intensive testing to ensure that it would be space-ready. Having instruments that have flight heritage guarantees the highest chance for mission success. The second requirement is for the electrical components to be able to endure and operate successfully during reentry. Not only is this implying that electronics must have high vibration tolerance, but also high heat and load tolerances. Since data transfer will take place during parts of the reentry phase, the computer must be able to process and send accurate data. If any equipment fails during reentry, then the overall mission fails. The third requirement is for the Command and Data Handling (C&DH) to occur through one flight computer. A flight computer would allow for automation, and having a single computer continually keeps costs down while efficiently performing the job. The fourth requirement is to have ram and SSD speed fast enough to read and handle the data that comes in. The final requirement is for the computer to be able to have a high enough process speed to collect an ample amount of data. These requirements are outlined in Appendix F.

Summary of Major Subsystem Elements

The Software and Avionics subsystem consists mainly of a computer and the accompanying sensors used to collect data: an onboard computer (OBC), pressure transducers, thermocouples, and their accompanying analog-to-digital converters (ADC). The OBC serves as the central processing unit and data handling for the mission. This will directly interface with the Iridium transceiver and antenna to send the data during flight, and also will interact with other subsystems as necessary, including attitude determination (ADACS) and power, thermal, and environment (PTE) for power distribution. The code will also be stored on the OBC and will accomplish tasks such as the startup procedure from the sleep mode and then acquiring data from the sensors; during flight and re-entry, the main tasks will be this data acquisition and handling before it can be sent to the satellite for transmission (see the Communications section for details). Other than the OBC, the other elements of the subsystem are the sensors and ADCs. A Raspberry Pi Model 2B is used as a prototyping computer and will perform most of the same functions as the OBC mentioned above.

Thermocouples and pressure transducers will be placed around the craft with access points to the external surface of the vehicle, where they can acquire temperature and pressure data, respectively. The thermocouples will send an analog voltage signal to the internals of the

craft for data handling where it will be converted to a digital signal through an ADC, one for each sensor, before being sent to the OBC. Similar to this, the pressure transducers will also send a voltage signal to an ADC individually and then to the OBC, where the digital signal will both be converted and sent with the raw data through the Iridium satellites. In the OBC, the raw signal will be converted to their according values with calibration curves and will allow for analysis post-flight. The digital aspects of the subsystem include the NASA Core Flight System (cFS) and FreeRTOS, where the program will run. cFS will have the code for each aspect of the mission and will run on the FreeRTOS operating system, compatible with the OBC selected.

Selected Components and Justification

Selected components for the subsystem are shown in Figure 3 and are as follows: ISISpace On Board Computer with the FM Daughter Board for the OBC, Kulite XCE-80, and the MAX11254 for the pressure transducer and ADC, and the Omega High-Temperature Inconel Overbraded Silica Fiber-Insulated Thermocouple and MAX6675 for the thermocouple and ADC. As previously stated, NASA cFS and FreeRTOS are selected for the digital components. The ISISpace OBC was selected due to its flight heritage, computing capabilities for the mission, and mass concerns. The FM Daughter Board allows for access to pins on the OBC and the flight heritage with its onboard telemetry, flash storage, clock, and voltage monitoring. The Raspberry Pi used as the prototyping computer was selected due to its availability and price, and ease of use with its forums and depth of information regarding ways to use it. The thermocouples needed a large operating range due to the temperatures experienced at re-entry Mach numbers, and the one selected can give readings up to 980°C and provides transmission wires suitable to be connected to an ADC and OBC; the accompanying ADC is made for Type-K thermocouples, like the ones selected for the design, and allows for faster transmission. The pressure transducer has a minimal footprint when placed on the craft, and with the limited volume makes an excellent choice when also considering its operating ranges, which will allow it to withstand the loads in flight; the ADC chosen can handle multiple transducer inputs and requires less volume in the bus for operation. NASA cFS is an adaptable framework for unique space missions and has flight heritage, so constructing code to our needs with this background makes for a good choice. The OBC also runs FreeRTOS and the framework is compatible with it, so the code construction and implementation will be done smoothly.

Information Flow Chart

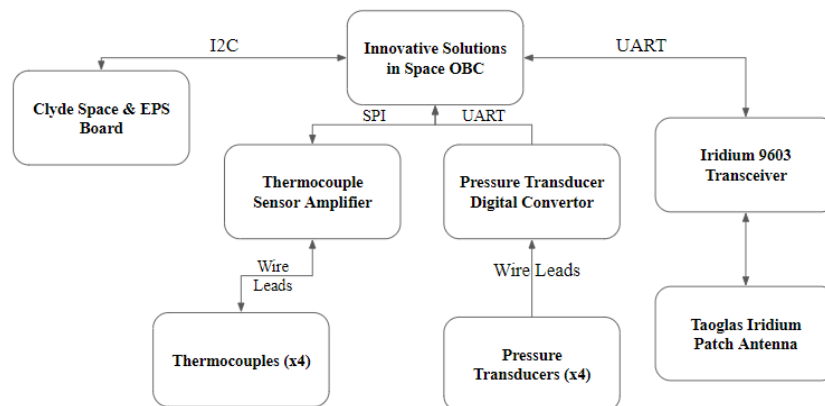

Figure 3: Diagram of control and data flow between components

Subsystem Assembly Details

Onboard the 1U bus containing all of the hardware, the OBC and its FM daughterboard will be mounted to the CubeSat frame so it is secured to the craft and everything else can be connected safely to its pins. Connecting the thermocouple and pressure transducers will be done through breakout boards with the ADCs; the sensors will be soldered onto the boards for a permanent connection that can survive the loads of launch. The pressure transducers require external power, so the lead wires for that will be attached to the EPS system, also with solder, so that the sensor can output a signal. As for the ADCs to the OBC, the FM daughterboard contains pins that allow for easier access to the General Purpose Input/Output (GPIO) ports, which is how the ADCs will be connected to the OBC. Once again, these will be soldered onto the daughterboard and from there, the pins are connected to the OBC itself so the data can be read in the code onboard. Connecting the OBC to the Iridium 9603 Transceiver is covered in the Communications section, but a socket adapter is used to go from the unique transceiver port to pins that can be used with the GPIO pins for the OBC, and also the pins for the Raspberry Pi in the prototyping stage.

Flight Software/Task Executables

The main difference between the final design and the prototype lies in the manner that the code is constructed and operates, but share the same functions. The final design, as stated in Table 2, will run on FreeRTOS and use NASA cFS and C/C++ as an embedded system, but for rapid prototyping, a Raspberry Pi is used with code developed in Python on Raspbian to simulate the tasks of shown in Table 3. Some of the other tasks that need to occur during the flight and experiment are clocking to ensure repeated and accurate data acquisition, ignition of experiment protocols to begin autonomously and in the correct phase of re-entry, and also to detect whether the craft is stable in flight, so the data is being acquired in a reliable state and not while tumbling through the atmosphere. Other general things done during the experiment include data collection and handling which comes from the thermocouple and pressure transducer, and also the transfer of the data using the correct protocols through the Iridium constellation.

Flight Software			
	Operating System (OS)	Frameworks	Programming Language
Final Design	FreeRTOS	core Flight Software (cFS)	C/C++
Prototype	Raspbian OS/Linux	-	Python

Table 2: Description of tasks for Software & Avionics

GENERAL TASKS		
Task	Details	Component(s) Involved
Clocking	To allow data collection and transfer to occur at exact and repeating timestamps.	ISIS OBC
Automatic Activation	For the system to begin the mission program on its own at the appropriate time window	ISIS OBC
Stability Detection	Ability for the system to detect effective stable conditions, allowing proper data collection and transfer.	ISIS OBC, IMU
Data Collection and Handling	Ability for the system to collect the necessary data from the sensors, and process them in order to export comprehensible data.	ISIS OBC, MAX6675, Kulite-X80, MAX11254, XCIB (Omega)
Transfer Data	Ability for the system to export data to the iridium satellite constellation.	ISIS OBC, Iridium 9603 Transceiver

Table 3: Description of digital components for Software & Avionics

Attitude Determination and Control Systems and Orbits

System Design Requirements

The Attitude Determination and Control Systems (ADACS) and Orbits subsystem has four design requirements for a successful mission. The first requirement is to ensure highly stable flight inside and outside the Earth's atmosphere, fitting within the constraints defined by Communications and Structures and Integration subsystems. The Communications subsystem requires that our CubeSat be able to communicate with the Iridium satellite constellation, meaning that the spacecraft must be oriented such that its antenna can send and receive a signal to or from Iridium. To ensure aerodynamic stability, a static margin of at least one spacecraft diameter is required. The Structures and Integration subsystem sets limits on the configuration and mass of the components within the CubeSat which would determine its static margin. The second design requirement is to determine and relay attitude measurements continually through flight and re-entry. The third design requirement is to optimize mass and system volume to meet requirements by limiting the mass contribution to 100 grams and volume contribution to 40 cubic centimeters. The fourth design requirement is to minimize the power consumption of ADACS, with a maximum consumption of 1 Watt. The described system requirements are outlined below in Appendix G.

Summary of Major Elements

The major elements of the ADACS design approach are the flush air data sensing system (FADS) and the aerodynamically stable design. The attitude determination is done with the

FADS system which will measure the pressure behind the shockwave that HEDGE will experience as it re-enters on each side of the nose of the craft. The analog pressure measurements will be converted to a digital signal and sent to the flight computer of HEDGE. The OBC will use the algorithms to convert the digital pressure measurements into angle of attack and angle of sideslip measurements showing the stability of the craft at a point in time. The craft uses a passive control approach to the attitude control. The craft's design is made to be aerodynamically stable by ensuring the static margin, which is the distance the center of pressure is behind the center of gravity, is at least the diameter of the craft. This aerodynamic stability should ensure the craft rights itself when it re-enters, and the FADS system will determine if the aerodynamic stability was successful in doing so.

All Selected Components and Justification

The aforementioned FADS system will be constructed to withstand the high temperature conditions experienced upon reentry. Four one millimeter pressure tap holes will be bored in the craft, one on each face of the nose cone, flush to the exterior wall and through to the interior, allowing pressure to be measured. 3/32" outer diameter (OD) McMaster-Carr 316 Stainless Steel tubing will be connected to the interior side of the hole. At 0.58 grams per inch, this tubing will allow us to stay within our mass budget. The thermal insulation provided by the structure of the craft will ensure temperatures do not exceed the 1,088 K maximum of the steel. Cole-Parmer IDEX Ethylene-Tetrafluoroethylene (ETFE) tubing will be fitted to the end of the steel tubes with a matching 3/32" ID, at 0.17 grams per inch. This material has a maximum operating temperature of 353K so it is necessary for the steel portion of the apparatus to be long enough to allow the flow to cool substantially. A McMaster-Carr Compression Spring will be used to hold the tubing together. Four Kulite XCE-080 miniature pressure transducers will record the data obtained from flow outside the craft. They will be located near the center of the craft, at the end of the flexible ETFE tubing. Based on the resolution of the onboard ADC, minimum pressure changes of 2.6 Pa will be detected during flight, allowing for a measure of attitude change. The four pressure sensors, 16.44 inches of steel tubing, 3.64 inches of ETFE tubing, and roughly 0.84 inches of spring will contribute approximately 14.3 grams of mass to the spacecraft. It will also have a volume contribution approximately 13 cubic centimeters, which are both within our subsystem limits.

Details of Subsystem Assembly

The FADS System will be assembled to properly gather the data, while accounting for heat transfer loads. The system connects the outside airflow to pressure sensors in the middle of the spacecraft using small holes on the face of the craft, a tubing system, and connecting methods. One port for pressure readings will be drilled in each face of the section at the back of the angled nose, leading to the tubing system. From this port, the air goes into the stainless steel tube which is adhered to the outer wall of the spacecraft by brazing the tube to the inconel wall. This tube connects to the ETFE tubing. The joint of these two tubes is held together by stainless steel wire by pressure fitting. The ETFE tubing leads to the inlet of the Kulite XCE-080 pressure sensors. Each tube extends around the pressure sensor to the back wall of the transition section. At the back wall, high temperature epoxy is used to glue the tube to the pressure sensor, the tube to the wall, and the pressure sensor to the wall. This connection allows for the leads of the sensor to be connected to the avionics system aft of the assembly. Identical tube assemblies connect to each port. This system assembly is shown in Figure 4.

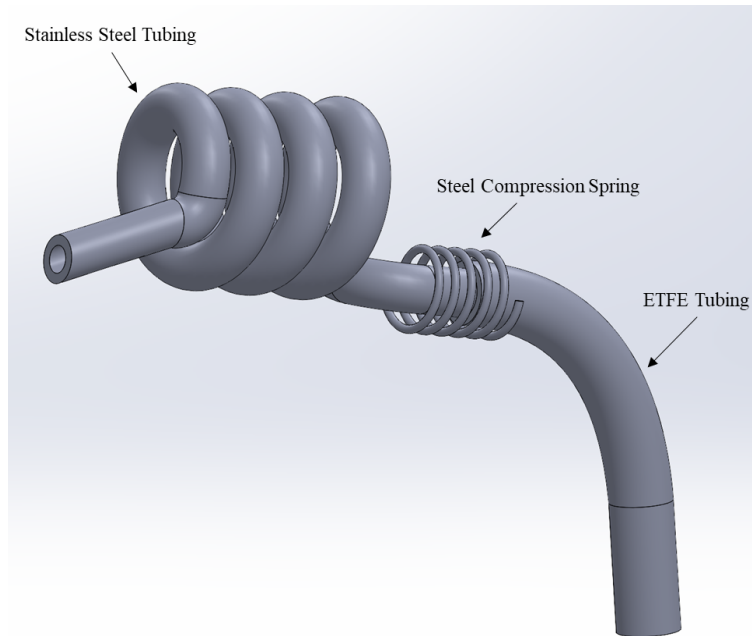

Figure 4: Isometric view of one pressure tube, with top left end connecting to wall

Analysis and Calculations

The angle of attack of the vehicle can be deduced by a difference in pressure over symmetrical faces, with known Mach and atmospheric pressure measurements. In order to model the expected difference in pressure across various re-entry stages, we performed Oblique Shock relations using the VT Compressible Aerodynamic calculator and Prandtl-Meyer Expansion relations using The University of Manchester's Prandtl-Meyer Expansion Calculator. Oblique Shock relations covered all positive turn angle's of the shock wave and once the turn angle became negative an expansion fan was formed and Prantl-Meyers relations were used.

The HEDGE vehicle has a half angle wedge measurement of 18.4 degrees (Θ), the turn angle of the shock wave can be correlated with the angle of attack (α) through the following two equations

$$\text{Turn Angle of Bottom face} = \Theta + \alpha \quad (1)$$

$$\text{Turn Angle of Top Face} = \Theta - \alpha \quad (2)$$

Using equations (1) and (2), the turn angle of the shock was evaluated from $\alpha = (0-25)^\circ$. Once a turn angle for each α was calculated, expected pressure ratios of each face were calculated, under the following known conditions of specific heat, $\gamma = 1.4$ and Mach number, $M = 20$. Based on the predicted temperature and velocity during re-entry derived from the initial conditions, Mach 20 is a reasonable estimate for re-entry. Once a pressure ratio is determined between the two faces at each respective turn angle, we can multiply the atmospheric pressure at any given altitude across the pressure ratio to determine the single static pressure experienced on one face. Once both face pressures are determined, the difference between the two is taken and associated with the respective α . Using the above method the following graph was produced.

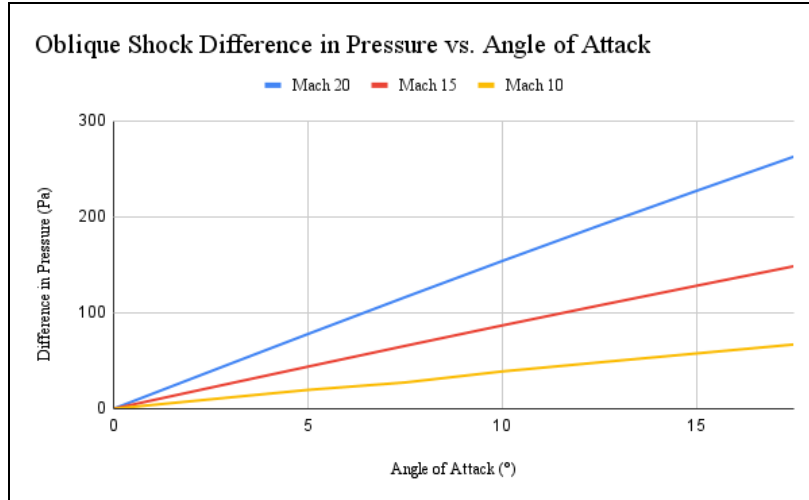

Figure 5: Difference in Pressure vs Angle of Attacks at Mach 20, 15, and 10 at an altitude of 80 km

Figure 5 displays the linear relationship between the pressure difference and angle of attack, providing expected attitude measurements at each respective pressure difference and speed. Figure 5 provides an analytical proof of concept that the FADS system will be able to provide a determination method for the attitude and a qualitative measurement of stability of HEDGE in terms of angle of attack, in addition to side slip as the front cone is symmetrical across both the x and y axis.

The altitude of the spacecraft and its orbital lifetime can be modeled based on the atmospheric conditions and spacecraft specifications. Using a MATLAB re-entry script, the spacecraft would hit the Earth's surface after approximately 16 days in orbit. The spacecraft will burn up during re-entry, therefore this estimate is not representative of the true orbital lifetime. However, the MATLAB script predicts the orbital decay as well as the heating rates of the vehicle which can be used to determine the predicted orbital lifetime. Figure 6 displays the altitude over time assuming an initial altitude of 214 km, a ballistic coefficient of 625 kg/m², and a coefficient of drag of 0.8.

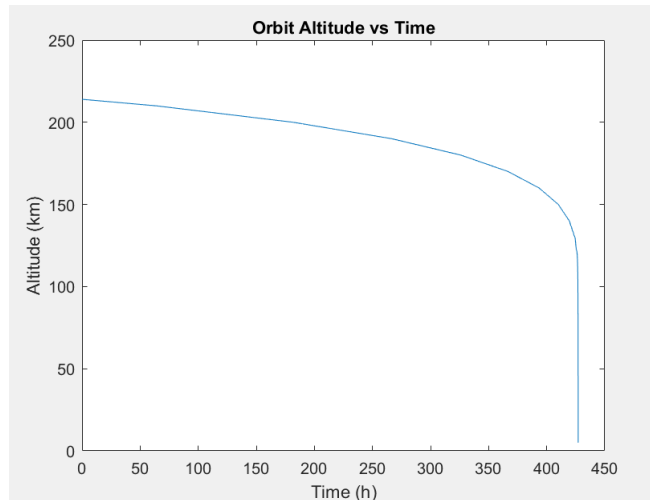

Figure 6: Orbit altitude vs time. The y axis displays the geometric altitude of HEDGE in kilometers. The x axis displays the time passed in hours.

Power, Thermal, Environment

Subsystem Design Requirements

The Power, Thermal, and Environment (PTE) subsystem has six different design requirements that have to be met for a successful mission (Appendix H). First, our battery and electrical power system (EPS) must supply the required power to all electronic subsystems according to our power budget (Appendix I). On the power side, the critical design topics included finalizing the EPS, solar panels, estimating power consumption and generation during the different phases of the mission, and modeling the power diagram on a component level. On the thermal side of design requirements, it is required that HEDGE does not outgas or deteriorate under space conditions while in orbit, make sure no electronics, materials, and structures exceed thermal tolerances during reentry temperature phases before the burn up, and ensure no large debris or thermal shielding survives reentry and is instead broken up by aerodynamic and thermal stresses after hypersonics phase. In addition to these detailed requirements, we must also ensure that the equipment (power source, shielding, wiring, etc.) conforms to CubeSat standards and ensure that our subsystem equipment does not exceed budget and mass limitations.

Major Subsystem Elements

Regarding power, the key subsystem elements involve having a battery, EPS, solar panels, and a power budget. HEDGE is expected to be in orbit for a period of 16 days. During this period, most of the sensors and electronics are expected to be in sleep mode, defined as a condition in which an embedded system enters a low-power mode. These sensors and electronics include the Kulite pressure transducers, thermocouples, pressure transducer analog to digital converter (ADC), and thermocouple digital converters. The main concern during this orbital period is calculating the minimal power draw (MPD) on the electrical power system (EPS), and ensuring that the average power generation from the solar panels is larger than the MPD. This includes ensuring enough power is generated and enough battery storage is included aboard the spacecraft to power the satellite while it is behind the earth and cannot create solar energy. This guarantees that HEDGE will have sufficient power to perform functions as planned during the reentry phase.

The selected EPS is the Clyde Space Starbuck Nano with either a 30W or 40W battery, with the final battery determination depending on weight limitations and battery requirements. This EPS was selected due to its flight legacy, relatively low weight, and multiple available voltage buses which are compatible with selected electronics. To generate power, this satellite will utilize four Clyde Space Photon Side solar panels mounted on each side of the reentry vehicle. These were primarily selected because of their high maximum power generation as well as their compatibility with the Clyde Space EPS. Each of these solar panels have been tested to generate a maximum of 3W of power in LEO orbit.

In terms of how the electronics interface with each other, a circuit diagram is represented by figure 7. As can be seen, the four Photon Side solar

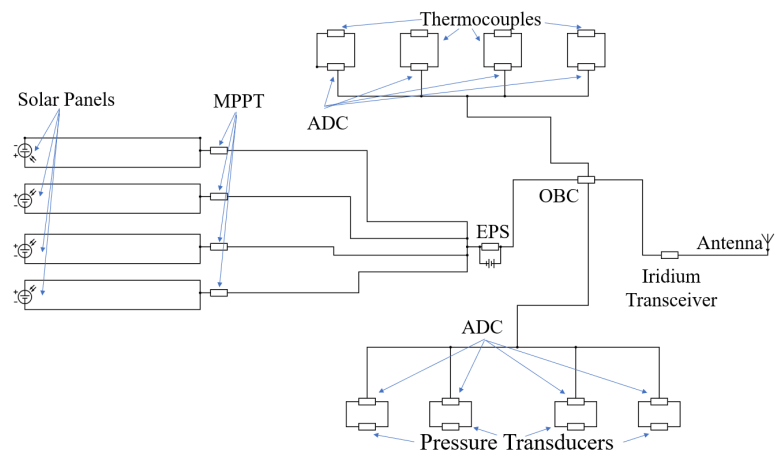

Figure 7: Full circuit diagram

panels each have their own Maximum Power Point Tracking (MPPT) and interface with the Clyde Space EPS. HEDGE also contains four thermocouples and four pressure transducers which each interface with their own analog to digital converter (ADC) located on the on-board computer (OBC). Finally, the Iridium transceiver, which communicates with the patch antenna, also interfaces with the OBC, which itself interfaces with the Clyde Space EPS.

With the current power budget (Appendix I), the predicted MPD is expected to be 1.36 W. This assumes that the EPS, onboard computer, and radio transceiver will be always fully operational during the mission. However, switching the radio transceiver to sleep mode during certain non-critical parts of the mission can reduce this MPD even further. It is predicted that the satellite will produce around 2.43 W of power while on the light side of the earth. This was done by creating an equation for the power generated in terms of axial angle (θ) and tilt angle (ϕ) and finding the average value of this equation for all angles from 0 to 360 degrees. This gives the average power generation of the spacecraft assuming random spinning. The equation is the following, where P_0 is the maximum power generation of one 1U Clyde Space Photon Side solar panel (3W) and P is the true resultant power generation:

$$P = P_0 * |\cos(\phi)| * (|\cos(\theta)| + |\cos(\theta + 90)|)$$
 Assuming an eclipse period of $\frac{1}{3}$ of the orbit, the average power generation throughout an entire orbital period is 1.621W, which is higher than the MPD.

The thermal subsystems elements include a high temperature nose cone material and a general ablative material. The nose cone material maintains the aerodynamic shape and protects the leading edge of the glider. The nose cone of HEDGE will be solid Inconel 718. Inconel has more flight heritage data that can be used when compared to other materials and it has superior thermal and strength characteristics under extreme temperature and mechanical conditions.

The main objective of the general ablative material (PFA Teflon) is to protect the spacecraft from hypersonic temperatures during reentry. This will be placed on the transition piece between the nose cone and the 1U cube, shown in figure 8. This is done to shield the electrical components and sensors placed within the nose cone and within the 1U cube. This will be implemented by panels. These material panels are triangular to match the curvature of the transition piece and to allow for the use of different materials.

For HEDGE, the material will be Perflouroalkoxyethylene (PFA teflon). This was chosen because of its method of ablation, thermal conductivity, maximum service temperature, density, and cost. PFA Teflon sublimates for ablation, meaning that it translates from a solid to a gas state and leaves no protective layer behind. This is optimal because PFA Teflon won't create a protective layer which can lead to more insulation and HEDGE surviving reentry. It has a thermal conductivity of $0.261 \frac{W}{m*K}$. This is considered a low thermal conductivity and will allow for ablation at a slower rate depending on the temperature of reentry. The maximum service temperature is the maximum temperature that the material can withstand before ablation begins. For PFA teflon, this temperature is 261°C. Reentry temperatures can reach upwards of 1,477°C (Federal Aviation Administration), meaning

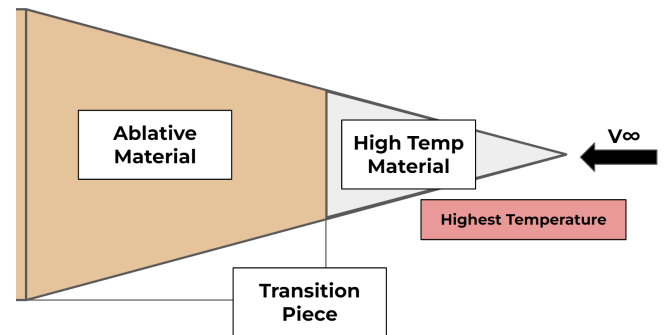

Figure 8: Nose cone transition piece

that HEDGE will burn up before hitting the ground. The density is $2200 \frac{kg}{m^3}$ and the cost is $12.5 \frac{USD}{kg}$ meaning PFA teflon is lightweight and inexpensive. For future work, different materials can be used instead of PFA teflon to test their viability for hypersonic reentry.

Analysis

In addition to the material properties of PFA teflon, mass loss rate and emissivity calculations were done to verify adequate burn up of HEDGE. The mass loss rate (m_t) of teflon was found using Hiester and Clark's report on standard evaluation for ablating materials. Where $m_t = 0.0076(q_{SRI,HW})^{0.55}(P_{T_2})^{0.27} \pm 10\%$, $q_{SRI,HW}$ is the heat transfer rate at the hot wall and P_{T_2} is model stagnation pressure (Hiester & Clark, 1966). Both of these numbers change with altitude. The approximation of 80 km was made as the beginning of reentry. This led to a heating rate of $10 \frac{kW}{m^2}$ on the top of the wall found by using Whites' equation from *Viscous*

Fluid Flow. $q_{SRI,HW} = \frac{k}{2h}(T_1 - T_0) \pm \frac{\mu U^2}{4h}$, where $\pm \frac{\mu U^2}{4h}$ refers to the lower and upper surfaces, respectively, k is the thermal conductivity of the PFA Teflon, h is the length of the material, and $T_1 - T_0$ is the temperature after the shock minus the ambient temperature before the shock. This led to a mass loss rate (m_t) of $0.014 \frac{kg}{m^2 s}$ dividing this number by density and the thickness of the panel (5 mm) gives us a burn up time of 13 min (Appendix J). However, as the altitude decreases the heating rate and mass loss rate increase, causing the burn up time to decrease due to an increase in the density of air. At 60 km the burn up time is 16 seconds. This suggests we will burn up upon reentry. Due to these times and the changes in velocity, temperature, and pressure, HEDGE will be able to complete the mission by sending both pressure and temperature data during re-entry. These calculations are shown in (Appendix J).

Structures and Integration

Subsystem Design Requirements

Functional and operational requirements and mission constraints for the Structures and Integration subsystem are shown in Appendix K, derived from the system level requirements and constraints to meet the primary and secondary mission objectives. In brief, the spacecraft must be able to deploy from its CubeSat configuration in ELEO to a re-entry configuration, which will withstand the hypersonic environment during the data transfer window before burning up in the atmosphere.

Final Design

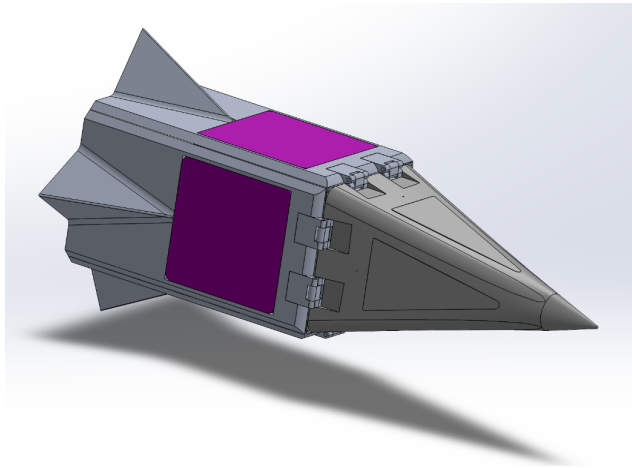

Figure 9: Spacecraft in re-entry configuration.

The spacecraft will consist of a payload section with a CubeSat standard 1U volume which will house most internal components, as well as four fin plates, which have a length of 2U and width of 1U with a fin integrated into each fin plate as pictured in Figure 9.

The fin plates will be attached to the main spacecraft through a set of double pin hinges on each of the four faces. Each face will have a symmetric pair of hinges that will allow the fins to rotate backwards and deploy to the aerodynamic test form. While also being able to fit within the 3U size constraints while stored. After deployment the fins will lie flush with the side of the sides of the 1U payload walls.

Twin double pin hinges were chosen to allow the fins to be flat and fit within the 1U face of the CubeSat deployer. Rather than have an obstruction outside of the 10x10cm square area from the pin of a single hinge design, the twin hinges provide a less aerodynamically obstructive design.

Solar panels will be fastened to the deployed outer surface of each fin plate. Harnessing from the solar panel to the electronics payload will follow a structural umbilical. To accommodate the 1U solar panels, the aerodynamic fins will only occupy the final 1U of each fin plate. Aerodynamic stability of the new design with shorter fins was verified with hypersonic stability calculations outlined below.

Fin Plate Deployment Mechanism

Torsion springs are necessary in order to deploy the fins from the CubeSat configuration to the re-entry configuration, as there are no external forces in space to move the fin plates. The mechanism to deploy the fin plate consists of four total torsion springs located next to each of the dual hinges. While stored in the CubeSat dispenser, the spring is loaded so that the fin plate is applying pressure to the box. As the spacecraft exits the deployment box, the torsion springs will deploy the fin plates which will fold back and get locked into the re-entry position via a weak permanent magnets.

Nose Cone Design

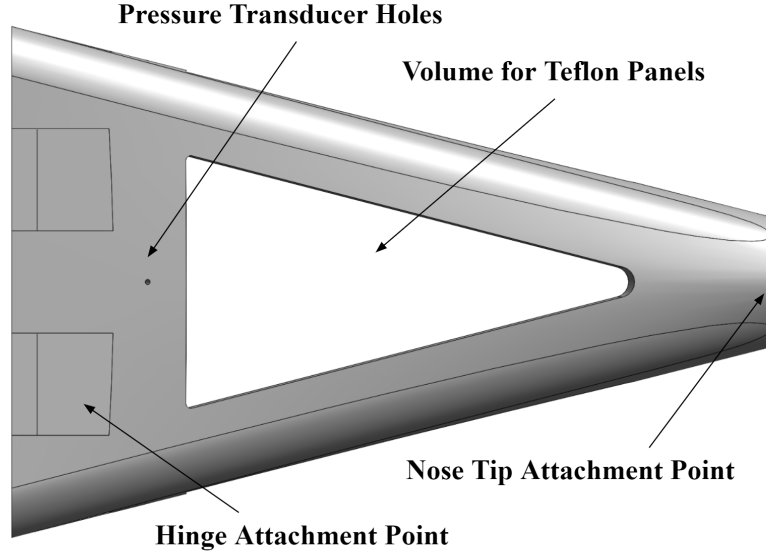

Figure 10: Side view of inconel nose cone transition

The nose cone transition can be seen in figure 10. The general nose cone and nose cone transition are largely unchanged in shape from the Preliminary Design Review, which consisted of a 35.5 mm conical tip and a square-circle transition. The changes that have been made focus on fulfilling the mission requirements of data collection and material testing. The first of which is addressed by the small 1 mm diameter holes drilled in the upper part of the nose cone transition. The second large change to the nose cone transition is the inclusion of Teflon panels on the flat faces of the transition area.

The small holes in the transition region are to allow the ADACS group to install a system of pressure transducers inside the nose cone to collect data. The Teflon panels are added for two main reasons. First, the panels act as shielding for the rest of the craft and are designed to ablate. Secondly, the panels serve as a trial run for other material testing as the panels are replaceable.

Internal layout

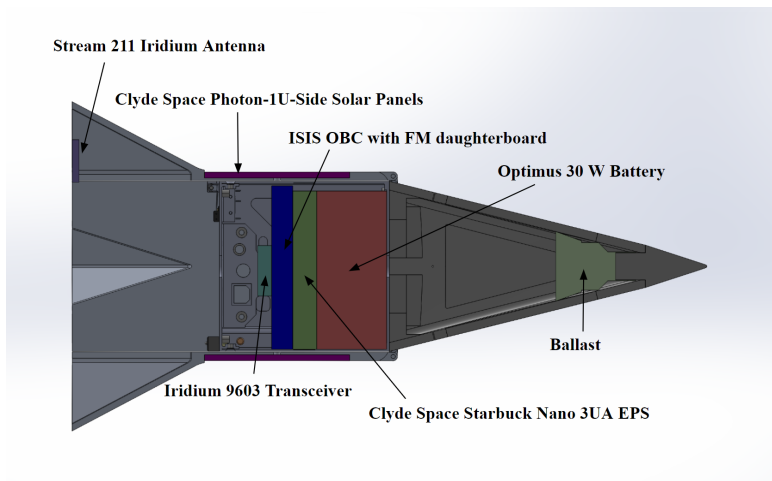

Figure 11: HEDGE Annotated Internal View

The internal layout can be seen in figure 11. The positioning of the internal components was refined from last year’s design. The main goal was to place the heaviest components (specifically the GOM battery and GOM board) as far forward as possible. This was done to move the center of gravity forward. As described below, the further forward the center of gravity, the better the static margin. The final positioning order (from front to back) of major components is as follows: Optimus 30 W Battery, Clyde Space Starbuck Nano 3UA EPS, ISIS OBC with FM daughterboard, and Iridium 9603 Transceiver.

Mounting of the internal components will be done using all thread rods. As designed for each internal component, four rods will be inserted through their corners to allow them to rigidly stack in place longitudinally within the payload section. All thread mounting will also be beneficial in reducing the heating of these components during reentry. Electronic components, such as solar panels, will require wire routes including either surface paths or with internal cavities that can be made using additive manufacturing methods.

Stability

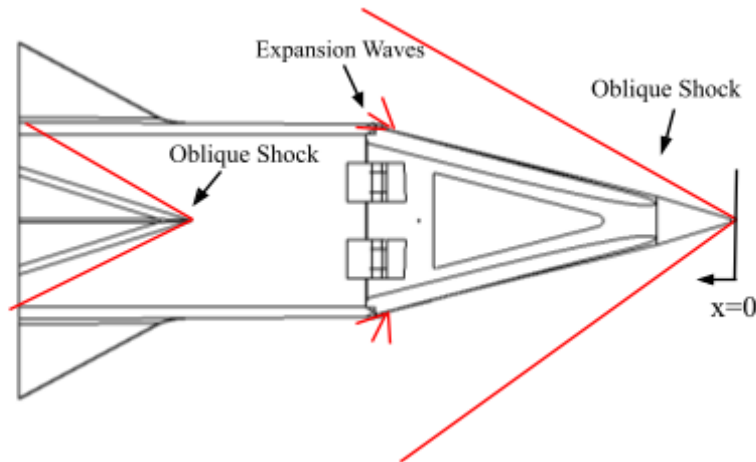

Figure 12: Oblique waves and Expansion waves that act on the craft during reentryD

In order to confirm this design met requirements, aerodynamic stability calculations were conducted. An indication of longitudinal static stability is the static margin, or the distance between the center of gravity (cg) and the center of pressure (cp). When the CG is in front of the CP, the static margin is positive and there is positive static stability. A static margin of one diameter is desired to ensure flight stability. To confirm the design meets requirements, the stability calculations must confirm that the static margin is positive.

The diagram in Figure 12 illustrates the shock waves that act on the craft as it reenters the atmosphere. The nose cone and the fins generate oblique shock waves and the hinge corners redirect the flow through the creation of expansion waves. Equation 3 was used to determine the center of pressure acting on the craft at angles of attack of 5° and 15°.

$$CP = \frac{\int x \cdot p(x) dx}{\int p(x) dx} \quad (3)$$

Equations 4-5 were used to determine the pressure distribution on the craft as a result of the oblique shock waves. Equation 4 describes the relationship between static pressure before and after the shock and Equation 5 describes the relationship between the total pressure before and after the shock. Equation 6 describes the relationship between static pressures before and after the expansion wave and was used to determine the pressure distribution on the craft as a result of the expansion fans.

$$\frac{p_1}{p_0} = \frac{2\gamma M_0^2 \sin^2 s - (\gamma - 1)}{\gamma + 1} \quad (4)$$

$$\frac{p_{t1}}{p_{t0}} = \left[\frac{(\gamma + 1) M_0^2 \sin^2 s}{(\gamma - 1) M_0^2 \sin^2 s + 2} \right]^{\frac{\gamma}{\gamma - 1}} \left[\frac{(\gamma + 1)}{2\gamma M_0^2 \sin^2 s - (\gamma - 1)} \right]^{\frac{1}{\gamma - 1}} \quad (5)$$

$$\frac{p_1}{p_0} = \left(\frac{1 + [(\gamma - 1)/2] M_0^2}{1 + [(\gamma - 1)/2] M_1^2} \right)^{\frac{1}{\gamma - 1}} \quad (6)$$

In these equations, p is the static pressure, pt is the total pressure, γ is the specific heat ratio, s is the shock angle and M is the mach number. Subscript 1 refers to the location after the shock or expansion wave, and subscript 0 refers to the location before the shock or expansion wave.

The CP at angles of attack of 5° and 15° at an altitude of 80 km and a Mach of 20 were found to be 28.93 cm and 29.91 cm, respectively. Using the Solidworks Evaluation tool, the center of gravity of the craft was determined to be 18.5 cm. Therefore, our calculations proved that the craft has a positive static margin, and subsequently, positive longitudinal stability. The static margins at angles of attack of 5° and 15° are 10.43 cm and 11.41 cm, respectively. As these values are both larger than one diameter of the spacecraft, the team is confident in the in-flight stability of this design.

Mass budget

The mass contributions from each subsystem are listed in Appendix L. The theoretical maximum system mass, constrained by the CubeSat dispenser, is 6,000 g. There is a contingency mass of 1,000 g listed to account for errors in manufacturing, approximation or future changes in components or materials. The predicted total vehicle mass is 3,640 g, and including the system contingency, the total system mass is 4,640 g.

Manufacturing

The components of the spacecraft that will be manufactured in-house include the body-nose transition and fins, which will be additively manufactured using direct metal laser sintering, and the threaded nose cone, which will be machined from a billet of Inconel. Direct metal laser sintering was chosen for the body-nose transition because of non-machinable or difficult to machine geometry in the part, such as channels for cables and sensors. The nose cone is a relatively simple part that can be machined on a lathe, although the material hardness may pose a challenge. The fin plates will be CNC machined out of aluminum and the fins will be attached using fasteners on the rear of the spacecraft in re-entry configuration.

Risk - Deployment of Fins

The main failure point that will affect mission success is the deployment of the fins and antenna. This can be broken down into 2 parts, hinges and deployment mechanism. If the deployment method fails to open the fins the spacecraft will not be stable during re-entry as well

as not getting the antenna deployed to allow for data transfer. If the hinges have a failure in either their deployment or structurally once they are deployed it will result in aerodynamic instability and mission failure.

To mitigate these risks the design minimizes moving components and makes use of a simple two pin hinge design to minimize chances of deployment failure at the hinges. The use of axial springs at the hinges that will be under tension while the craft is in the deployment box and require no outside signal to trigger will mitigate any communication or electrical error from causing the system not to deploy. To further mitigate the risks involved with the antenna not deploying it is mounted to the

Management, Team Roles and Responsibilities, Meeting, Collaborations, Reporting and Reviews

To organize this technical project, the class has been split into six functional teams, composed of undergraduate aerospace and mechanical engineering majors. The groups are as follows: 1) Program Management, 2) Structures & Integration, 3) Communications, 4) Software & Avionics, 5) Power, Thermal & Environment; and 6) Attitude Determinations and Control Systems & Orbits (ADACS). Table 4 below shows the functional team assignments for the 2022-2023 Capstone team.

Functional Teams	Members
Program Management	Zach Carroll , <i>Nicholas Haddad</i> , Thomas Yin, Andrew Culbertson
Structures and Integration	Daniel Fisher, Danielle Ashbahian, Joseph Abbe, Kevin Nguyen, Sam Kristy , Spencer Harris
Communications	Lauren Murphy, Kaiya Saunders , Hussain Asaad, Aidan Case
Software and Avionics	Joseph Lee, Mateo Nguyen , Mathew Quiram, Nicholas Storey, Jannik Grabner
Power, Thermal and Environment	Allen Liu, Aaron Liu, Doyle Dick , Jackson Stoner, Corin Myers
ADACS	Avery Goldberg , Grant Duemmel, Joe Beasley, Lucas Talbert, Sean Jones

Table 4: Team Member Roles

Each individual team within the overall Capstone team has a leader associated with them (bolded above). The Program Management team has a Program Manager (PM) and a Deputy Program Manager (DPM, italicized above), but the rest have one singular leader each to connect the Program Management team to the four to five members of each team. Each team leader meets with the PM and DPM once a week to once every two weeks, depending on the current approaching deadline.

The Capstone class meets twice a week in class, on Mondays and Wednesdays from 2 to 3:15. Each week, three of the six teams give a brief update in class to ensure the entire class is up to date on what they have been working on. Outside class, each team is encouraged to meet

regularly to stay on schedule and meet any upcoming deadlines. To ensure each team does so, the program management team utilizes *Trello*, the visual collaboration application. Each team has their goals for the entire year listed out with three columns: To Do, Doing, and Done. The Program Management team is constantly keeping track of what needs to be done by when to stay on schedule.

Schedule

Long Term Schedule

The project team inherited a long term schedule from last year’s project team. The goal of the schedule is to guide what large deliverables should be worked on during each semester. Semesters are divided into quarters, Q1 through Q4. Q1 and Q2 are the Spring Semester, and Q3 and Q4 are the fall semesters. The schedule below starts when the current members of the project joined and goes until the end of the project through its launch.

Schedule	2022		2023				2024				2025	
	Q3	Q4	Q1	Q2	Q3	Q4	Q1	Q2	Q3	Q4	Q1	Q2
Grant Funding and Licensing	[Ongoing]											
Preliminary Design Review	[Active]											
Critical Design Review			[Active]									
CubeSat Assembly					[Active]							
Software Development					[Active]							
Testing							[Active]					
Mission Readiness Review							[Active]					
Delivery to Antares									[Active]			
Launch & CubeSat Deployment									[Active]			
Deorbit & Data Collection									[Active]			
Data Analysis									[Active]		[Active]	
Documentation											[Active]	[Active]
Final Mission Report												[Active]

Table 5: Overall Project Schedule

The project is currently in Q1 2023, entering Q2 2023. According to the schedule (table 5), by the end of the semester we will have completed the Critical Design Review. This will entail each functional team contributing their work from the past two semesters to make a single document that is able to be presented to industry. Working on getting grant funding and licensing is an ongoing goal that will continue throughout the project. Once the Critical Design Review is finished, the project will have a solid plan to work on getting licensure for as well as to present to grant providers.. This would leave next semester’s project team to complete the CubeSat assembly and begin testing of all its systems as well as continuing work on acquiring licensure and getting onto a future rocket launch.

Functional team leaders broke these up into medium term plans and then into shorter tasks. These tasks were then assigned to group members on the project management tool “Trello”. Trello allowed the project management team to track who is doing what and the status of all active tasks. Once a team member completes the task, they mark it as completed in “Trello”.

Medium Term Schedule

Each functional team laid out their plans for the Spring 2023 semester in the Preliminary Design Review at the end of the Fall 2022 semester. This section will go through each functional teams' plans for the Spring 2023 semester.

Communications team's goal for this semester is prototyping the selected communication system that they designed the previous semester (Appendix M1). This is ongoing at the time of writing. This involves buying the selected components, assembly, testing, and review. Software and avionics has a similar prototyping schedule; buying components, assembling the prototype, testing, and review (Appendix M2). At the time of writing, the components are bought and the prototype is being assembled and tested. ADACS planned on designing the pressure sensors and testing in software. This will then allow them to determine the material and length of the pressure tubes. They also plan on selecting an algorithm for determining AoA and side slip (Appendix M3). At the time of writing, the pressure sensors are designed, and the design of pressure tubes is being finalized. Structures and Integration planned on doing software analysis on the PDR spec design. Then finish the design for the hinges and the outer body. Finally, doing software analysis on the final design at the end of the semester and potentially prototype the design (Appendix M4). At the time of writing, the software analysis of the PDR model is complete and the other teams' designs are being added into the final assembly. The design for the outer body and hinges is also complete. Power Thermal and Environment planned to do computer simulations for heat transfer and ablation in the early spring, as well as determining solar panel viability and material verification. In the late spring the team planned to test temperature sensor accuracy, as well as do final ablation simulations and final heat transfer model simulation. At the time of writing, the computer simulations are complete and solar panels have been added to the design. The temperature sensor testing and final ablation simulations are heat transfer simulations will be finished after the time of writing.

Cost

The 2022-2023 HEDGE team was granted \$4,000 by the University of Virginia to cover the costs of developing the Preliminary Design Review and Critical Design Review. While the Preliminary Design Review was mainly conceptual and did not require much funding, the Critical Design Review included a prototype demonstration that required many items to be purchased and 3D printed. This section will cover the expenses of this year as well as an estimated cost breakdown of the overall mission of HEDGE.

2022-2023 Cost Breakdown

A prototype was produced to present the overall shape of the hypersonic vehicle and to demonstrate the ability for the spacecraft to collect and transmit data via the Iridium satellite constellation. Specifically, the 3D-printed exterior of the vehicle hinged back and forth to visualize the transition from a 3U cubesat to a hypersonic vehicle and the interior was displayed separately to show the data collection from the pressure tubes and the transmission of the data to a base computer. The cost of the prototype demonstration is broken down into all purchased parts and materials 3D-printed in Appendix N. The total cost of the prototype was \$669.31. The team spent much less than the allowable budget of \$4,000 given from the University of Virginia. The budget may be able to be rolled over for next year's team to increase their funding, especially for more expensive expenses such as launch providers, the 1U CubeSat frame, metallic materials, and machining services.

Overall Mission Cost Breakdown

After the Critical Design Review, the team in the following academic year will be responsible for the most expensive parts of the mission, such as assembling the CubeSat and purchasing the onboard battery and Electric Power System. An estimated cost breakdown is outlined in Appendix O totalling approximately \$55,800.

Accounting for operational costs, software costs, facility costs, instrument costs, and other unforeseen expenses, the total cost of the mission is expected to increase substantially as it progresses through its development timeline (Wertz et al., 2011). However, the cost breakdown shows a rough understanding of the estimated cost and shows that the proposed mission would be no more expensive than most of the current CubeSat missions taking place today which can cost around \$200,000 dollars for a 3U (Park, 2022). Therefore, the cost breakdown of the overall mission of HEDGE is a sufficient indicator that the mission is financially feasible and that the next stage of the mission is appropriate.

Conclusion

HEDGE is a proof of concept mission to demonstrate the feasibility of using CubeSats as a means of low cost hypersonic flight testing. Hypersonic conditions are extremely challenging and expensive to test. By using low cost CubeSats, HEDGE offers the ability to test hypersonic flight conditions at an extremely low cost relative to traditional programs. Planned hypersonic technological advancement aligns with the DOD and with NASA's short and long term goals.

This program utilizes undergraduate students divided into six different functional teams. This emphasizes real world systems engineering skills and requires collaboration between all students in the class. Each functional team has a specific role in the mission and has accomplished many different tasks throughout the semester. The program management team has ensured timely progress on deliverables and ensured teams are up to date throughout the year. The communication team finalized component selection and organized the data collection through the iridium satellite constellation. The software and avionics team has set up data communication between the payload and the communications equipment including how to transfer data between different subsystems. The ADACS and orbits team has designed the pressure tap system to determine mach number and angle of attack as well as determine the orbit length. The power, thermal, and environment team determined burn up time, power usage including solar panel usage, and materials needed to stay hypersonic for long enough to collect data but still burn up. Finally the structures and integration team designed the outer section of the cubesat and is currently working on integrating all subsystems together.

Currently HEDGE is undergoing its critical design review to determine if the design is mature enough to begin fabrication and testing. We expect that the design components and systems will be finalized although more work will be needed regarding integration of system components. After completion of the critical design review next year's capstone class will begin fabrication and testing.

References

- Ailts, G. W. (2019, April 6). Simple_Mars_Reentry. *Github*.
https://github.com/gailtsufc46/Simple_Mars_Reentry
- Clark, S. (2022, February 9) *Antares Launch Timeline on the NG-13 Mission*. Spaceflight Now.
<https://spaceflightnow.com/2020/02/09/antares-launch-timeline-on-the-ng-13-mission/>
- Cooper, N. (2011, November 9). *DOD Eyes Improved Hypersonic Testing Capability with MACH-TB Project*. *ExecutiveGov*.
<https://executivegov.com/2022/11/dod-eyes-improved-hypersonic-testing-capability-with-mach-tb-project/>
- Dryer, J. (2017, November). *Nasa hypersonics overview*. In NASA Advisory Council's Aeronautics Committee Meeting (No. HQ-E-DAA-TN48981).
- Hiester, N. K., & Clark, C. F. (1966). Feasibility Of Standard Evaluation Procedures For Ablating Materials. NASA Contractor Report.
<https://collab.its.virginia.edu/access/content/group/c41659f4-7b61-470c-a4d4-d5870249b76b/Papers/FEASIBILITY%20OF%20STANDARD%20EVALUATION%20PROCEDURES%20FOR%20ABLATING%20MATERIALS.pdf>
- Office of Aerospace Medicine. Federal Aviation Administration. (n.d.).
https://www.faa.gov/about/office_org/headquarters_offices/avs/offices/aam/cami
- Park, P. (2022). *The Economics of CubeSats*. Alabrava.
<https://alabrava.net/the-economics-of-cubesats/>
- Wertz J. R., Everett D. F., & Puschell J. J (2011). *Space Mission Engineering: The New SMAD*. Microcosm Press
- White, F. M., & Majdalani, J. (2022). *Viscous Fluid Flow*. McGraw Hill. ISBN: 978-1-260-59780-6

Appendices

Appendix A

Definitions of the eight space mission architecture elements as defined in the Space Mission Engineering textbook (Wertz et al., 2011)

Subject	What the spacecraft observes (passive subject) or interacts with (active subject).
Payload	Spacecraft hardware and software that observe or interact with the subject/
Spacecraft Bus	The other spacecraft systems needed to support the payload.
Ground Segment	Communications equipment and facilities that communicate with and control the spacecraft.
Mission Operations	The people and software that run the mission on a day to day basis.
Command, Control, and Communications Architecture	How all the parts of the space mission communicate with each other
Orbit	The path of the spacecraft during its operational mission.
Launch Segment	How the spacecraft gets into orbit.

Table 6: Description of eight space mission architecture elements (Wertz et al., 2011)

Appendix B

Mission Concept graphic depicting a hypothetical deployment on the Antares launch. The current mission will attempt to utilize the new antares 330 second stage or another similar launch to achieve an initial ELEO orbit.

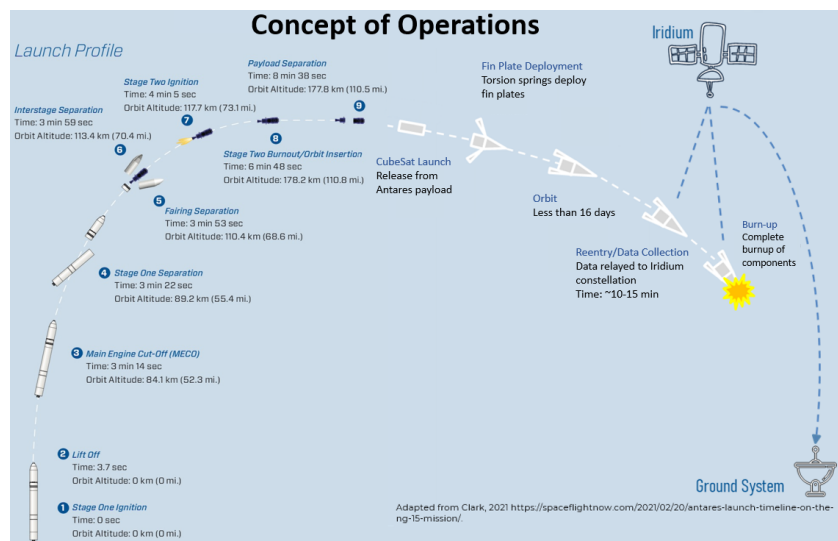

Figure 13: Mission concept on hypothetical Antares 200 second stage deployment

Appendix C

Functional Requirements, Operational Requirements, and Constraints

System Level Functional Requirements	
F1 (O1)	Hypersonic vehicle fins must autonomously be in deployed position during reentry
F2 (O1, O2)	Aerodynamic stability with correct orientation required during reentry
F3 (O1, O3)	Withstand launch and orbit conditions and environment
F4 (O1, O2, O3)	Sustain hypersonic flight during data transmission
F5 (O1, O4)	Conform to launch provider requirements (compatible with canisterized satellite dispenser)
F6 (O1, O2)	Ability to accommodate different material test panels on the Outer Mold Line

Table 7: System Level Functional Requirements

System Level Operational Requirements	
OP1 (O1)	Less than 16 day orbital lifetime
OP2 (O1, O2)	Automated, powered system control data collection and telemetry (including temperature and pressure measurements)
OP3 (O1, O2)	Test article must survive data collection but demise prior to impact

Table 8: System Level Operational Requirements

System Level Constraints		
C1 (O4)	Comply with CubeSat Standards	<ol style="list-style-type: none"> 1. 3U maximum size 2. Total mass < 6 kg
C2 (O1, O3)	Launch to Extreme Low Earth Orbit (ELEO)	~200 km Altitude
C3	Cost within amount granted from sponsor	~\$100,000

(O2, O3, O4)		
C4 (O1, O2)	Material durability and structural integrity during sustained flight	<ol style="list-style-type: none"> 1. Survive hypersonic flight during test window 2. No full reentry of any components
C5 (O4)	Comply with FCC regulations for space communications	

Table 9: System Level Constraints

Appendix D

Communications Design Requirements

Communication Design Requirements	
CM1[OP3,F3, C4]	Be able to transmit data to a satellite constellation and to a ground station
CM2[OP2]	Automated data transmission
CM3[OP2]	During re-entry transmit data every 10 seconds, and transmit data every hour in orbit
CM4[C3]	Select cost-effective components (<\$1000)
CM5[C1,F5]	Select lightweight components (<22g)
CM6[OP3,F3]	Transceiver and antenna compatible with satellite modem and re-entry environment
CM7[C5]	Compliant with FCC and federal regulations (added to constellation's registration)

Table 10: Communication Design Requirements

Appendix E

Communications component data

Radio: Iridium 9603 Transceiver
--

Price	\$199
Mass	11.4g
Volume	7.5 cm ³
Operating Temperature	-40 C to 85 C
Frequency Range	1.616 to 1.627 GHz
Data Transmission Rate	19 kbps
Power	Idle: 0.17 W Transmit: 0.725 W Receive: 0.195 W

Table 11: Iridium Transceiver Data

Antenna: Taoglas IP.1621.25.4.A.02	
Price	\$8.63
Mass	10g
Volume	2.5 cm ³
Bandwidth	10 MHz
Gain	2 dBi
Frequency range, polarization, and operating temperature coincide with transceiver	

Table 12: Patch Antenna Data

Communication Network: Iridium Satellite Constellation	
Price	\$34 per month
Frequency Band	L

Data Rate	17-22 Bytes/Second
Constant Transmission with complete satellite coverage	

Table 13: Iridium Data

Appendix F
Software and Avionics Design Requirements

Software and Avionics Design Requirements	
SA1[OP3, F3, F4, C4]	Radiation hardened/tolerant electronics with flight heritage (operate in ELEO)
SA2[OP3, F3, C4]	Must be able to operate in a reentry environment (under load, high vibration)
SA3[OP2, C1, C3]	Single flight computer to control data processing and tasking
SA4[OP2, C1]	Ram speed and SSD must be fast enough to process collected data (have the processing power to read/store collected data)
SA5[OP2, C1]	Be able to process 1000 bytes of data in a minute

Table 14: Software and Avionics Design Requirements

Appendix G
ADACS and Orbits Design Requirements

ADACS and Orbits Design Requirements	
A1[F2]	Ensure highly stable flight inside and outside the atmosphere fitting within the mass and layout constraints defined by Structures and Integration subsystems to have an adequate static margin
A2[OP2,F3]	Determine and relay attitude measurements continually through flight, with data transmission once every hour, and reentry, with data transmission once every 10 seconds
A3[F5,C1]	Optimize mass and system volume to meet requirements by limiting mass contribution to 100 grams and volume contribution to 40 cubed centimeters
A4[OP1]	Minimize power consumption of ADACS with a maximum of 1 Watt

Table 15: ADACS and Orbits Design Requirements

Appendix H
Power, Thermal, and Environment Design Requirements

Power, Thermal, and Environment Subsystem Design Requirements	
P1[OP1]	Sufficient voltage/current to supply all electronic subsystems according to a power schedule: peak power during atmospheric reentry data transmission, minimal power pre-glider deployment periodic data transmission
P2[OP1]	Battery has enough energy to power each subsystem and last the duration of mission
P3[F3,OP2,OP3, C4]	Ensure no material outgasses/deteriorates under space conditions
P4[F4,OP3,C4]	Do not exceed thermal tolerances of electronics, materials, and structures during reentry temperature phases
P5[F4,OP2, C5, C6]	Ensure no large debris or thermal shielding survives reentry and is instead broken up by aerodynamic and thermal stresses after hypersonic phase
P6[F5,C1]	Ensure that equipment (power source, shielding, wiring) conforms to cubesat standards
P7[C3]	Ensure that subsystem equipment does not exceed budget limitations

Table 16: Power, Thermal, and Environment Design Requirements

Appendix I power budget

Subsystem	Component	W			Duty Cycle (%)			Power Required (W)	% Power Used	Bus Requirements	Notes
		Sleep	Low	High	Sleep	Low	High				
Communications	Iridium 9603 Transceiver	0	0.8	1.6	0	100	0	0.8	0.04	4.5 V to 5.5 V	
Communications	Taoaglas Patch Passive Antenna	0	0	0	0	0	0	0	0	N/A	
Software/Avionics	Raspberry Pi 2 Model B	0	0	6	0	0	0	0	0	5.1 V	Only for Prototyping
Software/Avionics	Kulite XCE-80 Pressure Transducer (x5)	0	0	0.1	0	0	0	0	0	10 V to 15 V (preferably 10 V)	
Software/Avionics	Omega High Temperature Inconel Thermocouple (x5)	0	0	0	0	0	0	0	0	0 V	
Software/Avionics	ISISpace OBC w/ FM Daughter Board	0	0	0.4	0	0	100	0.4	0.02	3.3 V	
Power, Thermal, Environment	Clyde Space Starbuck Nano	0	0	0.16	0	0	100	0.16	0.008	N/A	
ADACS	N/A	0	0	0	0	0	0	0	0		
Structure/Integration	N/A	0	0	0	0	0	0	0	0		
Margin								0.26	0.16		
Total								1.4	0.84		

Figure 14: Description Includes how much power each part requires to function

Appendix J

Burn up calculations for PFA Teflon panel based on Hiester & Clark and Whites' equations

Key:		Unit Conversion:		From Paper	
Human Inputs		(W/m ²) to (BTU/ft ² *s):	8.80E-05	pT2 = atm	
Numbers from Table:		(Pa) to (atm):	9.87167E-06	Heat transfer rate: BTU/ft ² *s	
Compressible Flow Calculator Numbers:		(kg/m ² *s) to (lb/ft ² /s):	4.88243		
Textbook Appendix:					
SolidWorks Value:		T2 (K):	3768	Ambient Stagnation Pressure (Pa):	4.6E+08
		P2 (pa):	97	P02/P2 for M2:	2.1E+01
Gamma:	1.4	Density2 (kg/m ³):	8.9E-05	Stagnation Pressure (Pa):	2038
Gas Constant:	8.314	U2 (m/s):	841		
		Mu2 (N*s/m ²):	8.7E-05	Heat Transfer at Top Wall (W/m ²):	5314
Material:	PFA Teflon	Length to Material (m):	0.0906	Heat Transfer at Bottom Wall (W/m ²):	4974
Thermal Conductivity (W/m*K):	0.261	Reynold's Number:	7.8E+01		
Density (kg/m ³):	2.179			Heat Transfer at Top Wall (BTU/ft ² *s):	4.7E-01
				Heat Transfer at Bottom Wall (BTU/ft ² *s):	4.4E-01
Altitude (km):	80			Mass Loss Rate (lb/ft ² /s):	0.0017
Ambient Temperature (K):	196.65	Based on fillet:	0.0906	Mass Loss Rate (kg/m ² *s):	0.0085
Ambient Pressure (Pa):	8.86E-01			Mass Loss/Density (m/s):	3.9E-06
Ambient Density (kg/m ³):	1.57E-05			Thickness of Material (m):	0.005
Ambient Viscosity (N*s/m ²):	1.32E-05			Burnup Time (s):	1.275
Velocity (m/s):	8000			Burnup Time (min):	21
Mach Number:	20				
Half Angle of Nose:	18.4				
Angle of Attack:	5				
Oblique Shock Angle (top):	23.4				
Oblique Shock Angle (bottom):	13.4				
Speed of Sound (m/s):	48				
M2:	4.0				
T2/Ta:	19				
P2/Pa:	109				
rho1/rhoa:	5.7				

Figure 15: Burn up calculations

Appendix K Structures and Integration Design Requirements

Structures and Integration Design Requirements	
S1[F3,O P3,OP1]	CubeSat must withstand aerodynamic and launch forces
S2[OP3, C4]	Hypersonic test vehicle must withstand hypersonic environment/flight during data transfer window
S3[OP3, F1]	Frame must deploy fins and burnup in atmosphere, hypersonic vehicle must burnup in atmosphere after conclusion of flight
S4[C1]	House all communication and computing equipment inside test vehicle
S5[C1]	House all deployment mechanisms within max 3U CubeSat (10x10x30 cm)
S6[C1]	Entire system weighing less than 6 kg
S7[O3]	CubeSat and test vehicle system must be easily assembled in house without specialized tools
S8[F2]	CubeSat center of pressure must be behind center of gravity, ensuring an adequate static margin for aerodynamic stability
S9[F5]	CubeSat must be compatible with launch provider dispenser device
S10[O2, F6]	Frame must support modular material test panels and sensors

Table 17: Structures & Integration Subsystem Level Requirements and Constraints

Appendix L HEDGE Mass Budget

Part	Mass (g)	% of Total Mass
------	----------	-----------------

Teflon (Panel)	1.8	0.04%
Optimus 30W Battery	268.0	5.78%
Clyde Space EPS	86.0	1.85%
Inconel Nose Cone	99.7	2.15%
Inconel Rectangular Pyramid	1150.9	24.81%
Tungsten Ballast	615.0	13.26%
1U Frame	92.0	1.98%
4x Aluminium fin+plate	942.5	20.31%
Iridium 9603 Transceiver	11.4	0.25%
U.fl/IPEX Cable Mini PCI to SMA Female Low Loss Coaxial Cable	18.0	0.39%
Connection Parts Estimate	25.0	0.54%
Taoglas Patch Antenna	10.0	0.22%
ISIS OBC w/ FM daughterboard	100.0	2.16%
Kulite XCE-80 Pressure Transducers	1.6	0.03%
Omega K-type Thermocouples	15.0	0.32%
MAX 6675 Thermocouple ADC chips	5.0	0.11%
MAX 11254 ADC chips	5.0	0.11%
316 Stainless Steel Tubing	9.5	0.21%
IDEX Chromatography Tubing, Natural ETFE	0.6	0.01%
Compression Spring	2.5	0.05%
4x Clyde Space Photon Side Solar Panels	180.0	3.88%
Total Allocated Vehicle Mass	3639.6	78.45%
System Contingency Mass	1000.0	21.55%
Total System Mass	4639.6	100.00%
Theoretical Maximum System Mass	6000.0	129.32%

Table 18: Total System Mass Budget

Appendix M
Medium Term Team Schedules

Communications schedule

Jan 2023	Feb 2023	March 2023	April 2023	May 2023
Buy components				
	Purchase Iridium subscription			
	Testing our radio and antenna connection to Iridium			
	Test components with other subsystems			
			Make any adjustments as we see necessary	
				Critical Design Review

Figure 16: Communications Schedule

Software and Avionics

January	February	March	April	May
Purchase components				
Conceptual Design for Prototype (include IMU to system)	* IMU data to be added, need to review options			
	Assemble & Connect components together	* use CubeSAT simulator to ensure components fit, spaced correctly		
	Interface with other subsystem prototypes			
		Perform tests on hardware, software		
* depending on testing, next year's team can continue to follow a recommended testing plan based on our results, or progress to manufacturing if design passes tests			Compile test results & future recommendations for CDR	

Figure 17: Software and Avionics Schedule

ADACS

January 2023	February 2023	March 2023	April 2023	May 2023
Design pressure sensor taps on CubeSat model				
	Test positioning of pressure sensor inlets for optimal placement using CFD			
	Determine the material and length of pressure tubes			
	Design an orbit with variable launch point parameters from ELEO			
			Select algorithms used for determining AoA and Sideslip angles	
		Prototyping FADS for testing, equipment testing, airflow loss testing in tubes		

Figure 18: ADACS Schedule

Structures and Integration

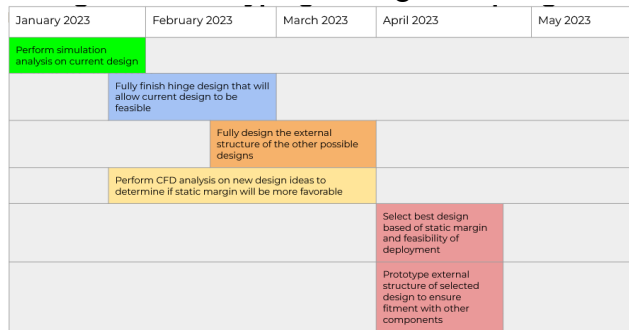

Figure 19: Structures and Integration Schedule

Appendix N

Fall 2022 to Spring 2023 prototyping cost breakdown

Part	Team	# of Units	Cost/Unit (\$)	Notes	Total Cost (\$)
Iridium 9603 Transceiver	Comms	1	140.00	\$40 for shipping	180.00
Iridium Subscription	Comms	3 (months)	32.50	\$40 for first month	105.00
Stream 211 Iridium Antenna (Prototype Antenna)	Comms	1	42.91	\$40 for shipping	82.91
U.fl/IPEX Cable Mini PCI to SMA Female Low Loss Coaxial Cable	Comms	2	3.14	N/A	6.29
Taoglas Patch Antenna	Comms	1	16.62	N/A	16.62
Connection Parts	Comms	1	15.84	\$6.99 for shipping \$0.84 for tax	23.67
RockBLOCK 9603	Comms	1	299.95	\$40.38 for shipping \$16.16 for tax	356.49

10 Pin Accessory Cable	Comms	1	4.95	N/A	4.95
Raspberry Pi 2 Model B	Software & Avionics	1	35.00	N/A	35.00
Pressure Transducer	Software & Avionics	4	84.26	N/A	337.04
Thermocouple	Software & Avionics	2	6.39	N/A	12.78
3D printed material	Structures & Integration	1	N/A	\$5/in ³	50.00
					Total: \$1210.75

Table 19: Cost breakdown of prototype demonstration for the Critical Design Review

Appendix O

Final design cost estimation breakdown.

*These parts are approximations based on Professor Goyne's estimates and online research and are subject to change

Part	Team	# of Units	Cost/Unit (\$)	Notes	Cost (\$)
Teflon (panel)	PTE	1	79.72	N/A	79.72
Optimus 30 W Battery	PTE	1	6200.00	N/A	6200.00
Clyde Space Starbuck Nano 3UA EPS	PTE	1	6600.00	\$250 for shipping	6850.00
Clyde Space Photon-1U-Si de Solar Panels x4	PTE	4	4000.00	\$250 for shipping	16250.00
Custom PCB for antenna attachment	Comms	1	100.00	N/A	100.00
Custom PCB	Comms	1	200.00	N/A	200.00

for transceiver					
Iridium 9603 Transceiver	Comms	1	140.00	\$40 for shipping; must reorder for future	180.00
Taoglas Patch Antenna	Comms	1	16.62	Must reorder for future	16.62
Connection Parts	Comms	1	15.84	\$6.99 for shipping \$0.84 for tax	23.67
Iridium Subscription	Comms	9 (months)	32.50	\$40 for first month	300.00
Solid Inconel Cone	Structures & Integration	1	3000.00	N/A	3000.00*
Inconel rectangular pyramid (main body)	Structures & Integration	1	4000.00	N/A	4000.00*
1U CubeSat frame	Structures & Integration	1	1700.00	N/A	1700.00*
Aluminum fin plates	Structures & Integration	4	125.00	N/A	500.00*
Inconel fins	Structures & Integration	4	1250.00	N/A	4000.00*
ISIS OBC with FM daughterboard	Software & Avionics	1	6860.00	N/A	6860.00
Kulite XCE-80 Pressure Transducers	Software & Avionics	4	1440.00	N/A	5760.00
Omega K-type Thermocoupl	Software & Avionics	4	111.00	N/A	440.00

es					
MAX 6675 Thermocouple ADC chips	Software & Avionics	4	12.00	N/A	48.00
MAX 11254 ADC chips	Software & Avionics	1	12.00	N/A	12.00
316 Stainless Steel Tubing (3 ft)	Attitude Determination and Controls Systems	1	47.70	N/A	47.70
Idex Chromatography Tubing, Natural ETFE (5ft)	Attitude Determination and Controls Systems	1	39.70	N/A	39.70
Compression Spring (Pack of 12)	Attitude Determination and Controls Systems	1	8.27	N/A	8.27
FCC experimental license application	Program Management	1	35.00	N/A	35.00
					Total: \$55,830.39

Table 20: Estimated cost breakdown of overall HEDGE mission