

# **Quantitative ACL Tibial Guide: Improving Clinical Outcomes of ACL Reconstruction Surgery**

A Technical Report submitted to the Department of Biomedical Engineering

Presented to the Faculty of the School of Engineering and Applied Science

University of Virginia • Charlottesville, Virginia

In Partial Fulfillment of the Requirements for the Degree

Bachelor of Science, School of Engineering

**Tzuyu Cheng**

Spring, 2023

Technical Project Team Members

Na Hyun Bae

Jasmine Cao

Aaron Lin

On my honor as a University Student, I have neither given nor received unauthorized aid on this assignment as defined by the Honor Guidelines for Thesis-Related Assignments

Mark Miller, MD, Department of Orthopedic Surgery

Ian Backlund, MD, Department of Orthopedic Surgery

## **Quantitative ACL Tibial Guide: Improving Clinical Outcomes of ACL Reconstruction Surgery**

**Na Hyun Bae<sup>1</sup>, Jasmine N. Cao<sup>1</sup>, Tzuyu Cheng<sup>1</sup>, Aaron Lin<sup>1</sup>, Ian Backlund<sup>2</sup>, Mark Miller<sup>3</sup>**

<sup>1</sup> Department of Biomedical Engineering, University of Virginia

<sup>2</sup> Department of Orthopaedic Surgery, University of Virginia Health

<sup>3</sup> Division of Sports Medicine, Department of Orthopaedic Surgery, University of Virginia Health

### **Abstract**

Anterior cruciate ligament injuries are among the most prevalent knee injuries; however surgical treatment has a high rate of failure due to inconsistencies. The goal of our capstone design project is to redesign the tibial guide for ACL reconstruction surgery in order to reduce variability in the location of the drilled bone tunnels and improve postoperative knee stability. The current guides on the market utilize anatomical landmarks identified through arthroscopy to locate the tunnel placement, which can cause inconsistent tunnel locations. Our advisor Dr. Mark Miller has patented a design that utilizes measuring components to identify the anteroposterior distance to bring a quantitative element to the surgical procedure. We identified mechanisms to incorporate these features while maintaining the clinical usability of the device by comparison to current models, namely the Arthrex AR-1510.

We created three main prototypes that incorporated measurement features that provide increased accuracy in the measurement of tibial plateau length, and indentations that rest on the shin for increased stability of the guide during the surgical procedure. We added two retractable shin stoppers, one on the vertical handle of the tibial guide and one on the bottom of the curved target arm of the guide, that are able to adjust in length according to the relative distance from the guide to the tibia. An offset drilling point was also added on the sides of the target arm which allows the endpoint of bone tunnel drilling to be consistent with standard reconstruction procedures while changing the measuring point. Adjustments were made in each prototype to create a tibial guide with the most holistic functions in the most simplistic form which provides orthopedic surgeons with maximum efficiency during an ACL reconstruction surgery. The resulting design has improved accuracy given a desired target with only ~0.2 mm error.

**Keywords:** Anterior Cruciate Ligament, Orthopedic, Medical Devices, Surgical Tools, Tibial Guide, Reconstruction Surgery, Anteroposterior Distance

## **Introduction**

The anterior cruciate ligament (ACL) is one of the four major ligaments in the knee that helps stabilize the knee joint. It runs diagonally in the middle of the knee, connecting the thigh bone (femur) to the shin bone (tibia). This helps to prevent excessive forward movements of the tibia and provides rotational stability to the knee. The injury is often caused by sudden stops and changes in direction. Thus, athletes in sports, such as basketball, football, and soccer, are more prone to ACL tears. The biomechanics of female bodies also tends to put them at a higher risk for ACL injuries<sup>1</sup>. Furthermore, the ACL is the most commonly injured ligament in the knee with 100,000 to 200,000 annual reports of sprains and tears, just in the United States<sup>2</sup>. Although there is such a high incidence rate of injury, surgical treatment still has issues with high failure rates. About 10-15% of patients who undergo ACL reconstruction report unsatisfactory outcomes and need subsequent surgeries<sup>3</sup>.

There are two main approaches to treating an injured ACL: nonsurgical treatment and surgical reconstruction<sup>1</sup>. Nonsurgical treatment, such as a brace and physical therapy, can strengthen the

surrounding ligaments to provide stability; however, surgical reconstruction is necessary to restore the internal structures and enable maximum stability. This might not be necessary for older patients but those that want to return to their sport or other activities will require surgical treatment. Moreover, recurrent instability of the knee, due to the torn ACL, can cause degenerative damage to other parts of the knee, such as the cartilage. Surgical treatment is also typically required when the ACL is completely ruptured.

To perform ACL reconstruction surgery, the surgeon must first make a new ACL from a graft of replacement tissues, which will be chosen on a case-by-case basis<sup>4</sup>. A common source is a portion of the patellar tendon, which connects the kneecap (patella) to the tibia. Then, arthroscopic techniques are utilized to locate the torn ACL to keep this a minimally invasive surgery. The injured ACL is removed. Afterward, drills are used to create bone tunnels in the tibia and femur to allow the new ACL graft to be placed and secured<sup>5</sup> (Figure 1). Surgeons use a tool, called a tibial guide, to locate the target position along the tibial plateau so that the drill will reach the desired location.

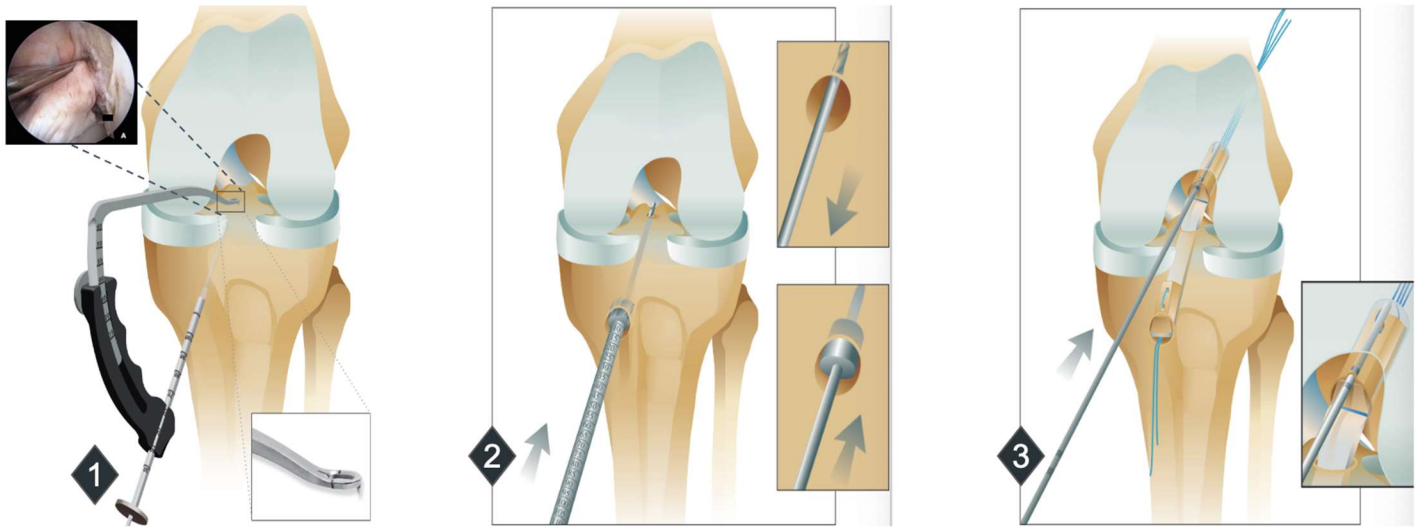

**Figure 1: Diagram of bone tunnel placement and securing of a graft<sup>6</sup>.** With the help of arthroscopic cameras, the tibial guide is placed on the location for the replacement ACL. A drill goes through the pin guide to create a bone tunnel. The ACL graft is pulled through the bone tunnels and secured.

The issue with the procedure that causes the high failure rates is the reliance on arthroscopic cameras to determine the proper placement of the bone tunnels. Surgeons often use an anatomical landmark to help with locating the optimal location, such as the use of the posterior horn of the lateral meniscus, the c-shaped cartilage in the knee. However, this is not an exact location and can often be difficult to identify through the use of arthroscopy. This leads to inconsistencies and inaccuracies with tunnel placement. Thus, subsequent surgeries are needed to address the failures.

### ***Hypothesis and Aims***

Studies have shown that the use of the anteroposterior (AP) distance to place the tibial bone tunnel can help with consistent and ideal placement, where maximum favorable results were seen when tunnels were placed at 35-46% of the total AP distance<sup>7</sup>. AP distance is defined as the distance between the front of the knee joint to the back, which can be measured along the medial position of the tibial plateau. From these results, we hypothesize that the adoption of AP distance into the reconstruction procedure will help with consistent bone tunnels, decrease failure rates, and improve clinical outcomes. We propose that the

AP measurement can be added as a feature to the tibial guide to provide a quantitative element to the surgical procedure and reduce the reliance on visual landmarks for proper tunnel placement. Thus, we will redesign the tool, with three main aims, to implement these improvements and ensure the success of this project.

The first aim was to design a measuring component for the tibial guide to measuring the desired AP distance along the tibial plateau. After determining the best AP distance to maximize the biomechanics of the patient, the surgeon will need to be able to set that distance on the tibial guide so that location can be located within the patient's knee. This spot on the tibial plateau will be the endpoint of the drill and mark the location of the graft within the knee space. The mechanisms to perform this action will be incorporated into the upper arm of the tibial guide.

The second aim was to design a targeting component to aim at the endpoint. This will be used to allow the surgeon to set a desired length and angle for drilling the bone tunnel. Current tibial guides have a stable

upper arm that does not move, which means the pin guide will always direct the drill to the tibial hook (Figure 2). However, the addition of an upper arm that measures AP distance will mean that the upper arm is no longer a stable entity and will require an adjustable, targeting lower arm to make sure the drill is still directed at the tibial hook. This mechanism is necessary to make sure the drill goes to the desired spot after the measurement is made.

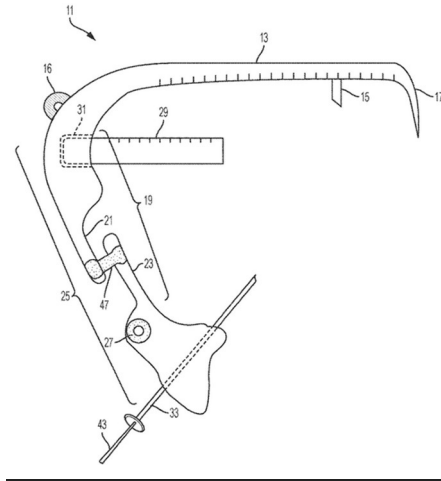

**Figure 2: Arthrex AR-1510 tibial guide.** This model contains similar features to ones widely used in reconstruction surgery. A tibial hook that sits on the desired location on the tibial plateau. The pin guide always points at the tibial hook, no matter the chosen angle/distance needed for the patient.

The third aim was to perform iterative testing on knee models to measure the accuracy of the AP distance and bone tunnel placement. The design of the two mechanisms described in aims one and two require testing to make sure they function as expected. We want to determine the margin of error when creating bone tunnels with our devices. Additionally, we need to make sure the dimensions of each part are suited for use in various-sized patients. Moreover, this means that we need feedback from surgeons to ensure the usability of the device in the operating room. Data collected from each prototype will support the development of the next.

### ***Design Constraints***

The design constraints on this project include the need to maintain similar dimensional aspects to existing designs as well as to follow requirements outlined by our advisor, Dr. Mark Miller, patent<sup>8</sup>. We want to maintain similar dimensions to make sure the device still fits comfortably within the surgeon's hands and the limited space available in the knee space. Moreover, this allows us to incorporate the quantitative features, without altering the procedure by much. The dimensions must also allow a range of motion that captures patients of varying sizes. Lastly, since the original idea comes from a patent created by our advisor, we have to make sure that our designs stay within the purview of the patent.



**Figure 3: Engineering Drawing from Patent.** This drawing outlines the constraints surrounding the mechanisms required in our device. The most important features are the measuring and targeting components.

### **Results**

#### ***Device Iterations***

The design process resulted in three main prototypes, with smaller iterations between each of these designs. Each step increased the complexity of the mechanisms but simplified the use of the device. There were also additional changes that supported the overall

functionality of the device in a surgical setting due to valuable feedback from our surgical advisors. Moreover, there was a change in idea from our first prototype to the second. We initially wanted to be able to use the tibial guide to measure the entire AP distance of the tibial plateau. However, that would require removing the tibial guide after first marking the total AP distance, determining the optimal AP distance for the patient, resetting that distance on the device, and then continuing with the surgery. This involved the need for too many moving parts in the tibial guide and was not efficient. We received guidance from our advisor about the possibility of utilizing MRI scans to first calculate the optimal AP distance for the biomechanics of the patient and use that AP distance with our device. This was the approach we followed for the second prototype and the remainder of the project.

The first prototype utilized a two-part measuring component with the shin stopper and the measuring arm. Both of these components slide to fit nicely against the shin of the patient and to allow maneuverability along the tibial plateau. The distance between the end of the shin stopper and the tibial hook marks the AP distance, which could be used to measure the total distance and also be set at a specific distance to enable drilling. These two moving parts utilize a screw to secure the distances once set. The targeting portion has a rotational hinge, which allows the pin guide to swing closer or farther to the tibial hook, depending on the necessary AP distance. This complements the sliding measuring arm.

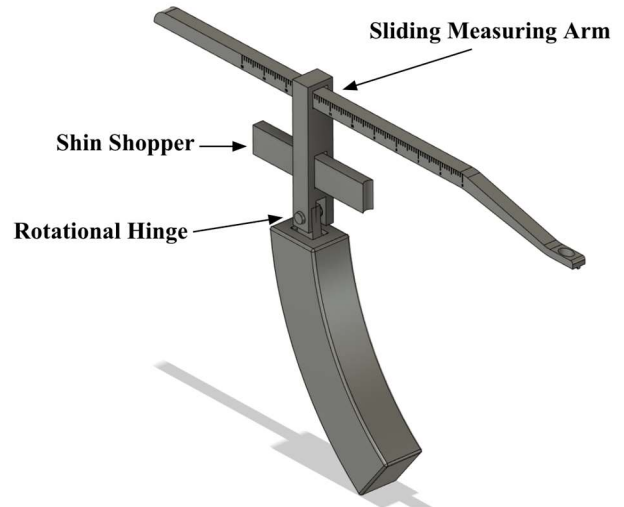

**Figure 4: Prototype One.** Includes components that allow measuring of total AP distance and setting a desired distance. A rotating targeting component allows the pin guide to be directed at a moving tibial hook.

The second prototype still can measure the entire AP distance, but that mechanism is no longer necessary due to the use of MRI scans. The measuring component is simplified to only require one moving part, just the upper shin stopper. Therefore, the measuring arm is now a static component, where the AP distance is still measured from the end of the upper shin stopper to the tibial hook. The upper shin stopper is also altered to have a more ergonomic design. The targeting component now has a lower shin stopper to help with the stability of the tool once inserted into the knee. The rotational hinge has been changed to an extendable arm to still create an adjustable targeting mechanism but eliminate the need to calculate an angle along two different axes. The targeting arm already slides along an angled piece, which allows the surgeon to determine the angle of the bone tunnel, so utilizing an extendable feature simplifies the need to deal with two angles. The offset pin guide was added due to the change in procedure to incorporate the use of the AP distance. The AP distance is measured from a medial position along the tibial plateau, but the bone tunnel will need to be

drilled along a diagonal due to the diagonal nature of the ACL. Therefore, the pin guide needs to direct the drill at an angle, as opposed to a straight-on as before.

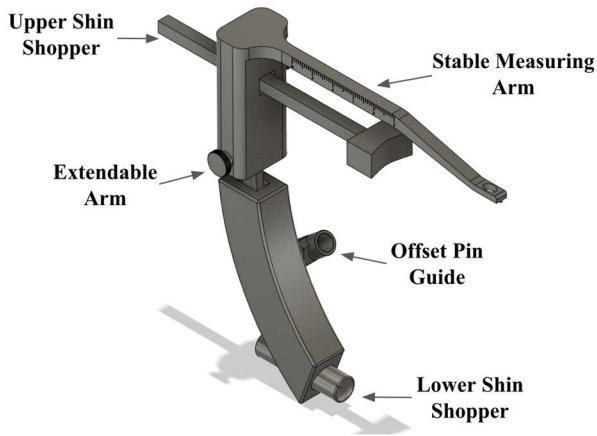
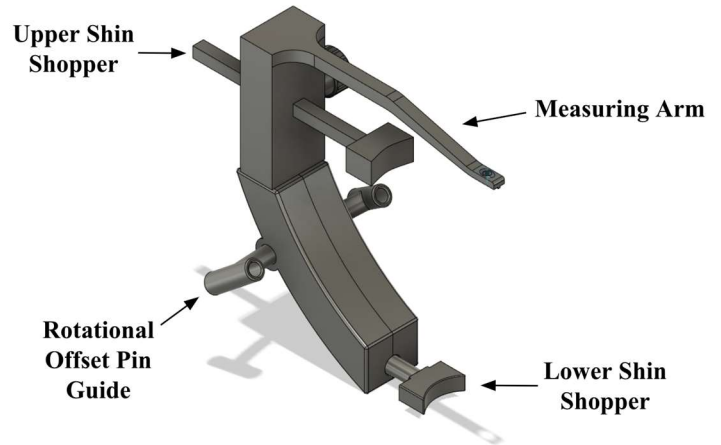

**Figure 5: Prototype Two.** Removes excess moving parts. Offset pin guide to allow the bone tunnels to be drilled at an angle. Improved stability with a lower shin stopper.

### *Final Prototype*

The final prototype has a few smaller changes with the biggest redesign being the offset pin guide. It can be seen in Figure 6. For the tibial guide to be used for either the left or right knee, the pin guide will be offset on a rotational plane. Depending on which knee the surgery is being done, the pin guide will offset to the corresponding direction, and the guide will always aim towards the target location indicated by the measuring arm. Most components are functionally the same with some design changes such as the lower shin stopper. The lower shin stopper was redesigned to be similar to the upper shin stopper, and the upper shin stopper length was reduced. These dimensional changes create a better fit around the shin and improve efficiency in clinical use. Lastly, the extendable arm was removed as it was deemed unnecessary. Due to the static measuring arm, which is similar to current models, the targeting arm no longer needs to be redirected to the tibial hook for each measurement. The upper shin stopper will be the main focal point that allows the ability to measure. Therefore, the

targeting arm will be at a constant distance from the tibial hook and only needs to pivot along a radial distance to the hook.

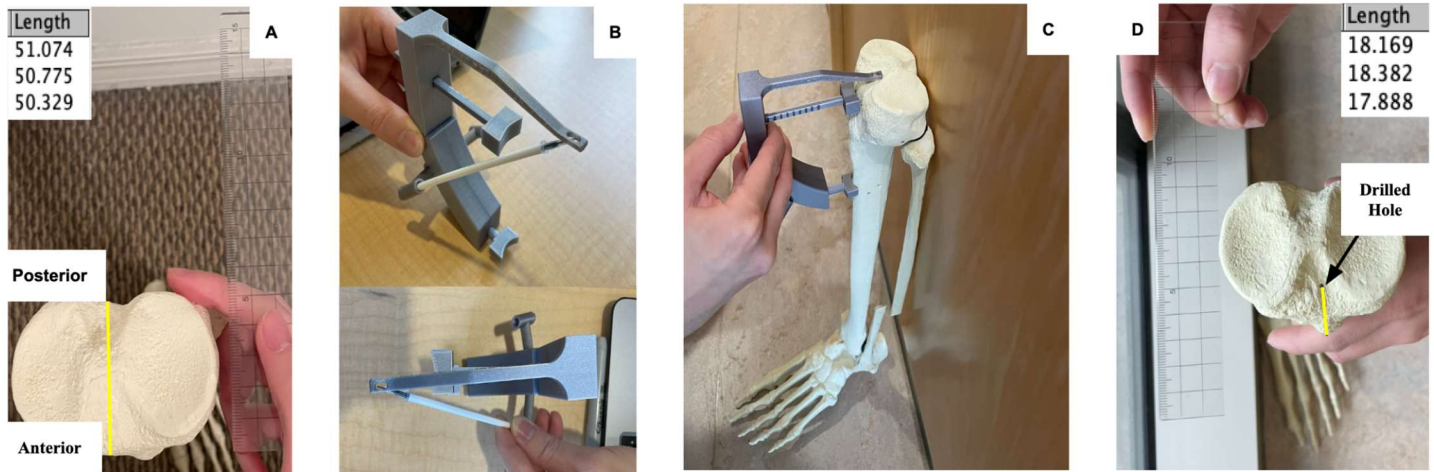

**Figure 6: Prototype Three.** The offset pin guide follows a rotational plane to accommodate left or right knee surgery. The lower shin stopper was redesigned to a more ergonomic design similar to the upper counterpart.

### *Simulation*

To test the accuracy of the new design, we simulated the bone drilling procedure according to how the new tibial guide would be used and then measured the drilled distance to check if it marked the desired location (Figure 7). An MRI scan would first be performed to calculate the total AP distance of the tibial plateau (Figure 7A). Then, the surgeons would use this distance along with other measurements of the patient to determine the most biomechanically optimized location for the bone tunnels. In this simulation, we chose an optimal location to be 35% of the AP distance. The tibial guide would then be set to this AP distance, utilizing the markings along the upper shin stopper, which denotes the distance between the concave part of the shin stopper to the tip of the tibial hook (Figure 7C). A drill will follow along the pin guides to the tibial hook and create a bone tunnel. We measured the AP distance of the drilled location to compare it to the desired distance originally calculated. The results are summarized in

Table 1. Although the drilled distance was not exactly at the target distance, it was very close with only an error of about 0.2 mm.



**Figure 7: Simulated Bone Tunnels.** (A) Simulated MRI to find the total AP distance of the tibial plateau. (B) Simulated pin guides and targeting mechanism of drills. (C) Positioning the tibial guide with the desired AP distance calculated from the measured total AP distance. (D) Measuring the drill distance.

Total AP Distance	50.726 ± 0.306 mm
Target AP Distance (35% of Total)	17.75 mm
Drilled Distance	18.146 ± 0.202 mm

**Table 1: Summarized Results from Simulated Bone Tunnels.**

## Discussion

### **Conclusion**

The results of the simulated bone tunnel drilling showed that our design is capable of producing bone tunnels that reach a desired distance. With further adjustments, this shows promise for a tibial guide that can create accurate and consistent tunnel placement that utilizes quantitative elements. Although the results of our simulation did not create a drill distance that was exactly on the target, it was only off by a small margin. Moreover, this simulation utilized

measurement markings on the upper shin stopper at every 5 mm and was still able to provide our close result. Further adjustments with more defined and frequent measurement markings will allow for more accurate drill distances.

The final design was able to meet the requirements outlined by aims one and two. The device was able to utilize an optimal AP distance as a measurement to set a desired distance for bone tunnel placement. Additionally, the device has a targeting component that always faces the tibial hook, no matter the distance set. We were able to add additional features that complemented these changes to the tibial guide, namely the offset pin guide, which allows us to still perform the reconstruction feature as usual but incorporates how an AP distance is measured.

The project failed in the amount of testing that we had originally planned in Aim 3. Although we were



unable to do direct testing with each iteration, we received surgical feedback from our advisor for each prototype. Moreover, we were able to simulate the use of the device to provide a proof of concept. We also utilized existing models as a basis for dimensional adjustments to the device. To further improve on the current state of the design, further testing is required, some of which are described in the methods and future works.

### ***Impact***

The quantitative tibial guide designed in this project will help to reduce the failure rates of ACL reconstruction surgery. Furthermore, it will help in postoperative stability in patients, which will improve clinical outcomes. This will be especially important for athletes who need to return to their sports and other people who require maneuverability in their knees in their daily life. This device will remove the need for surgeons to find an anatomical landmark when determining bone tunnel placements, which can be difficult due to the quality of vision from arthroscopic cameras. Surgeons can now also utilize an AP distance to find the best, biomechanically optimized location for the replacement ACL. Moreover, this change still allows the surgery to stay a minimally invasive procedure. Although arthroscopy is no longer necessary with this device, it should still be used to give surgeons some visibility of the operating area.

### ***Limitations***

The timeframe of the project was a limiting factor, as we were unable to perform as many tests as we wanted. It took longer than expected to produce each prototype after planning time to receive feedback from our advisor. Moreover, it was difficult to find the right opportunity to receive access to the 3D printer at the UVA Orthopedic Center. However, later in the project, we were able to get access to a 3D printer from Professor Christopher Highley, which

was more accessible to the team and increased the production of the prototypes. This delay also prevented us from doing clinical testing, such as utilizing the device in cadavers and allowing other surgeons, in addition to our advisors, to test the efficiency of the device. The use of 3D-printed plastic might also cause issues when testing with drills and other surgical tools.

The tolerance level of the 3D printers changed the way we had to develop our prototypes. Since the device is relatively small, the specific mechanisms of how each component fits and works together have only about a 0.5 mm margin. We had to run a few tests before understanding how much room we had. Additionally, the printers were unable to print small details such as our engraved measurements, which we had to manually add after the prints. This affects the simulations as it introduces another form of error when determining the accuracy. Lastly, the tolerance levels in the printers also prevent us from printing proper screws and screw holes, which means we need to find other sources to make these holes to secure our sliding components.

### ***Future Work***

Because we were unable to perform extensive testing, future work should include more in-depth testing of the prototype such as testing on various knee models for the simulation, testing the drilling on foam knee models, or cadaver testing. Cadaver testing will allow more coverage over differing patient populations such as older, younger, previously injured patients, etc. The collected data then can be compared to the patient's MRI data to test the device's accuracy. With these test results, iterations can be done to the prototype based on the results from the testing. From the next iteration, more testing can continue. To improve comfort for the user such as doctors and patients, dimensional adjustments to the components should also be done. Continuously iterating the

prototype is important but once the prototype reaches a more usable design, research needs to be done to find an optimal material for the guide. Weight, material stability, grip, biocompatibility, etc. must be considered when choosing the material for the tibial guide. Previous substantially equivalent devices can also be used to guide and determine the material.

## **Materials and Methods**

### ***Design and Printing of Prototypes***

The design of each prototype first started as sketches on paper and was then developed using computer-aided design software, Autodesk Fusion 360. The prototypes were then printed utilizing polylactic acid (PLA) on the 3D printer in the UVA Orthopedic Center and later in Dr. Highley's lab. We printed each component separately and fitted it together afterward. This involved the need to give each joint component slightly smaller or larger to account for the printer's tolerance. Moreover, components with curved hollow spaces needed to be printed in half, due to the need for support when printing. It was difficult to remove the supports from these areas when printed together. Drills and screws were later necessary to secure moving parts together.

### ***Simulated Testing***

The lower knee model was obtained from the UVA Orthopedic Center. We simulated an MRI scan by taking a photo of the tibial plateau with a ruler placed at the same depth as the plateau. We utilized ImageJ to take measurements of the total AP distance and averaged the distances. Then, we calculated 35% of this total distance to simulate the calculation of a target distance for the bone tunnels. In an actual procedure, other components of the patient would be necessary to determine an optimal distance. This distance was set on our device, utilizing the marking on the upper shin stopper. We marked where the tibial hook was to simulate the endpoint of the drill. This marking was then measured again in ImageJ, from a

picture of the tibial plateau and ruler, to determine if the location is within range of the target. A simulated pin guide was also inserted through the offset pin guide holes to see if it would reach the tibial hook.

### ***Proposed Clinical Testing***

After finalizing the design of the mechanisms and dimensions, we would like to print the device using stainless steel, similar to the materials used for current models. Then, use it on cadavers and actual drills to see how it would work in a real-world setting. Similar to the simulated testing, we would gather MRI scans and determine a target AP distance before drilling and then measure again after to see how accurate the drill tunnel was. Moreover, these measurements of the bone tunnel and replaced ACL can then be put into biomechanic software, such as OpenSim, to determine if this will improve the stability of the patient compared to measurements of a tunnel made from standard arthroscopy approaches. This could further show the benefits of utilizing a quantitative measurement in ACL reconstruction.

## **End Matter**

### ***Author Contributions and Notes***

Bae, N., Cao, J., Cheng, T., and Lin, A. created CAD designs, constructed prototypes, performed a simulation, and wrote the final report. Backlund, I., and Miller, M. advised on device designs. The authors declare no conflict of interest.

### ***Acknowledgements***

We would like to give special thanks to our capstone advisors Dr. Mark Miller and chief orthopedic resident Dr. Ian Backlund for providing the project idea and guidance. Additionally, we would like to thank orthopedic resident Dr. Pradip Ramamurti for assisting in the developmental steps. We would also like to thank the capstone instructors Dr. Timothy Allen, Noah Perry, and Dr. Shannon Barker. Lastly,

we also want to thank Dr. Christopher Highley for allowing us to utilize his lab for our project.

## **References**

1. ACL Injury and Treatments. *Yale Medicine*  
<https://www.yalemedicine.org/conditions/acl-injury-treatments>.
2. Evans, J. & Nielson, J. I. Anterior Cruciate Ligament Knee Injuries. in *StatPearls* (StatPearls Publishing, 2022).
3. Costa, G. G. *et al.* Minimizing the risk of graft failure after anterior cruciate ligament reconstruction in athletes. A narrative review of the current evidence. *J. Exp. Orthop.* **9**, 26 (2022).
4. ACL Reconstruction Surgery: Procedure and Recovery | HSS. *Hospital for Special Surgery*  
[https://www.hss.edu/condition-list\\_acl-surgery.asp](https://www.hss.edu/condition-list_acl-surgery.asp).
5. Anterior Cruciate Ligament (ACL) Injuries - OrthoInfo - AAOS.  
<https://www.orthoinfo.org/en/diseases--conditions/anterior-cruciate-ligament-acl-injuries/>.
6. Transtibial ACL Reconstruction for BTB Grafts. 6.
7. Rayan, F. *et al.* Review of evolution of tunnel position in anterior cruciate ligament reconstruction. *World J. Orthop.* **6**, 252–262 (2015).
8. Miller, M. D. (73) Assignee: University of Virginia Patent.