

DEVELOPING AN ADAPTOR FOR THE NASAL CANNULA FOR FACIAL PLASTIC SURGERY

A Technical Paper submitted to the Department of Biomedical Engineering
Presented to the Faculty of the School of Engineering and Applied Science
University of Virginia • Charlottesville, Virginia
In Partial Fulfillment of the Requirements for the Degree
Bachelor of Science, School of Engineering

By
Michael Epps
May 7, 2023

On my honor as a University student, I have neither given nor received unauthorized aid on this assignment as defined by the Honor Guidelines for Thesis-Related Assignments.

ADVISOR
Samuel Oyer, M.D., Department of Otolaryngology

Developing an Adaptor for the Nasal Cannula for Facial Plastic Surgery

By:

Michael Epps, Undergraduate Department of Biomedical Engineering
Kareem Hassan, Undergraduate Department of Biomedical Engineering
William Sande, Undergraduate Department of Biomedical Engineering

Advisors:

Samuel Oyer, M.D., Department of Otolaryngology
Claudia Gutierrez, M.D., M.S., Resident, Department of Otolaryngology
Rachel Jonas, M.D., Resident, Department of Otolaryngology

Word Count: 3465
Number of Figures: 7
Number of Tables: 1
Number of Equations: 3
Number of Supplements: 0
Number of References: 14

Developing an Adaptor for the Nasal Cannula for Facial Plastic Surgery

Abstract

In facial plastic surgery the administration of anesthesia via monitored anesthesia care (MAC), a form of anesthesia where the patient is partially sedated, rather than general anesthesia which carries a greater risk of morbidity. For cases involving MAC a nasal cannula is placed over the nose of a patient to supply oxygen as well as measure CO₂ levels. The nasal cannula, however, is obstructive to much of the face, especially the nose, upper lip, and upper cheeks, and as such surgeons at the UVA department of otolaryngology often resort to placing the nasal cannula within the mouth of a the patient. While this solution is operable, the design of the nasal cannula is not fit for the human mouth so the patient will often remove it in their sedated state, forcing the operating surgeon to break sterility and adjust the cannula within the mouth. This decreases surgical efficiency and increases the time needed for the procedure. Currently the alternative to using the nasal cannula is the use of an oropharyngeal airway (OPA), an invasive device placed within the mouth. This project attempts to redesign the nasal cannula so that it is minimally obstructive and less invasive for a patient undergoing MAC. The device itself was based upon the existing design of an OPA and designed to ergonomically fit within the mouth while minimizing any distortion to facial tissue. After undergoing multiple iterations of design in Autodesk Fusion360, which were then 3D-printed, a final design was fabricated using thermoplastic polyurethane (TPU) filament. Multiple prototypes were compressed on an instron to determine the bulk modulus of the device. Finally a novel procedure for measuring air flow was devised to determine the device's ability to maintain air flow under pressure.

Keywords: anesthesia, 3D printing, nasal cannula, facial plastic surgery, medical device, operating room procedure, air flow testing, mechanical testing, compression testing, ergonomics

Introduction

Significance

Facial plastic surgery reconstructs or reshapes structures of the face such as the nose, lips, and cheeks after an injury (e.g. dog bite, skin cancer resection), or to change existing features present. In 2021, a total of 22.4 million plastic surgery procedures were performed.¹ Monitored anesthetic care (MAC) is the first choice for surgical anesthesia in 10-30% of all surgical procedures, meaning that potentially 2.2 to 6.6 million plastic surgery procedures a year could utilize MAC.² Facial plastic surgeries are often performed under MAC, which is also known as conscious sedation, rather than general anesthesia.^{3,4} MAC allows for the patient to be sedated, making them unaware of their surroundings, but still breathing independently . This prevents having to perform an endotracheal

intubation, or placement of a breathing tube, to perform the surgery. Using MAC avoids the risks associated with general anesthesia and endotracheal intubation such as injury to teeth, lips and gums, bleeding, and aspiration of gastric contents leading to pneumonia.³⁻⁵ MAC is especially preferable to general anesthesia when possible in younger patients and patients with significant comorbidities.^{3,4,6} However, under MAC oxygen supply and end-tidal carbon dioxide monitoring is still required via a nasal cannula.^{3,4}

Currently, MAC is performed with a nasal cannula containing two channels: one which delivers oxygen to the sedated patient and another which returns carbon dioxide for monitoring of ventilation by an anesthesiologist. A cannula being used on a patient can be seen

pictured below in Figure 1. In the trauma setting, some patients have significant disruption of their nasal anatomy preventing the use of the standard nasal cannula to deliver oxygen. Additionally, usage of a nasal cannula may also dry the nasal mucosa, leading to epistaxis (nosebleed).^{7,8} During facial plastic surgery specifically, the use of a nasal cannula as it is designed obstructs the surgical field. The current solution used by the UVA Department of Otolaryngology – Head & Neck Surgery (OHNS) during cases under MAC is to place the nasal cannula in the mouth to maintain surgical access to the face. However, since patients are partially awake they will frequently bite on the nasal cannula, thus compressing the tubing, or spit it out. Frequent repositioning of the cannula is often required during the operation to optimize oxygen flow and carbon dioxide detection. This interferes with surgical efficiency, prolonging length of sedation, increasing the cost of the surgery (mean cost of operating room time is about \$35 per minute), and risks contaminating the sterile surgical field.⁹ Thus, there is a need for a non-obstructive oral device to provide oxygen and monitor end-tidal carbon dioxide levels during facial plastic surgery operations.



Fig. 1 Woman with nasal cannula. This demonstrates the standard usage of the nasal cannula.

Previously patented designs for transoral administration of oxygen and monitoring of carbon dioxide through the mouth include designs similar to an oropharyngeal airway (OPA). However, OPAs displace the resting local anatomy of the jawline and lips thus complicating the surgery.¹⁰ Other designs are seated over the lips, again obstructing access to the surgical field. Alternate device designs that left the entire face exposed were composed of small parts with choking hazards for patients under any form of anesthesia.¹¹

Thus it can be concluded that in the current clinical environment, practices surrounding MAC are unacceptable for a surgery that affects millions every year. These practices not only make the surgery incredibly uncomfortable for the patient but also add time and complexity for the surgeon; this in turn increases the cost of surgery. If there was a way to save even one minute of surgery time during MAC cases, this could potentially save \$77 to \$221 million per year. This project attempts to redesign the nasal cannula so that it is minimally obstructive for the surgeon and less invasive for a patient undergoing MAC.

Innovation

There have been adaptations for the nasal cannula designed before, but none are viable for our needs or are still being pursued. Previously patented designs for transoral administration of oxygen and monitoring of carbon dioxide through the mouth include designs similar to an OPA. However, OPAs displace the resting local anatomy thus complicating the surgery.¹² Figure 2 below shows one of these previous designs. This design is seated over the lips, which obstructs access to the surgical field, and is only designed to fit a single nasal cannula, whereas the UVA Hospital uses a dual nasal cannula.

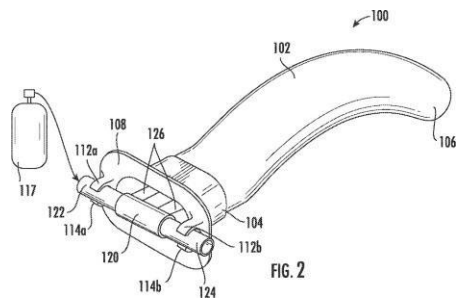

Fig. 2 Prior art for nasal cannula adapters. This device demonstrates flaws in existing work to solve this issue as the above device cannot work with dual-channel nasal cannulas and would obstruct access to the lips when in use.

Some existing designs for nasal cannula-adapting oral airways utilize small connecting pieces within the design. This is problematic as these small connecting pieces represent a choking hazard. These devices are only compatible with single-channel nasal cannulas, so that prevents the anesthesia team from monitoring end-tidal carbon dioxide levels while also providing supplemental oxygen to the anesthetized patient. Another issue with this design is that the dental plate rests outside the lips. This represents a significant hindrance as the lips and the surrounding soft tissue may be tissues of interest to an operating surgeon and the dental plate would be largely obstructive.

Project Aims

This project intends to design and produce an oral device that can connect and stabilize a dual-channel nasal cannula to enable easier usage during facial plastic surgery. The device is to be comfortable for a patient to use for an extended period of time while also minimizing obstruction and distortion of the soft tissues of the face. This device must also not obstruct the functions of the nasal cannula.

The created device is to be validated via mechanical testing with an Instron machine. Testing on the bridge of the device will determine the bulk modulus of the device and differences in the mechanical properties between a cleaned and uncleaned bridge.

The final aim is to establish and utilize a protocol to determine the rate of air flow through the device when placed under different masses as compared to the naked cannula line. This was to determine if there were any significant losses in air flow by using the device and to determine how resistant to change the air flowing through the cannula line was when different forces were being placed on the bridge of the device.

Results

Design Constraints

Primary constraints and goals for the construction of the device included creating a device which could fit in the mouth, was safe to use in the mouth, was stable in the mouth, did not obstruct or distend the soft tissues of the face during surgery, and did not obstruct the function of the nasal cannula.

The ability of the device to fit into the mouth was critical, as oxygen delivery and CO₂ monitoring can only occur through the nose or mouth. Utilizing the nostrils would unnecessarily obstruct access to potential surgical areas, therefore the device must be placed in the mouth. From there, safety in the mouth was a necessary requirement of the device.

Mouth stability was also a necessary constraint. The primary motivating reason for this project was risk of obstruction in the cannula line while a patient is semi-conscious. The device must provide additional stability to prevent obstruction of the cannula line. By focusing on stability, the patient would be less likely to find the nasal cannula uncomfortable in the mouth or spit it out.

Minimizing obstruction and tissue distortion was necessary in order to provide optimal surgical conditions. Failure to meet this constraint would mean that the operating surgeon would be operating on altered anatomy which can impair outcomes. The major areas of focus to minimize obstruction were the lips and the cheeks.

Minimizing the obstruction to the function of the nasal cannula was a necessary constraint, as the adaptor created needed to protect the nasal cannula line without impeding function.

Oxygen delivery to the patient during surgery is critical and the device must be able to protect the cannula line without reducing oxygen flow rate.

Along with the constraints specific to the problem the adaptor would be confronting, there were outside constraints such as cost and timing that needed to be addressed. There was no budget given for this project, so the prototyping development needed to be done in an inexpensive way with the equipment that was available at UVA. As the project needed to be completed in less than a year, iterations of the prototype needed to be completed as quickly as possible to allow for the best solution to be reached. These constraints were partially fulfilled by the decision to use 3D printing as a fabrication method.

Another constraint is that a non-hazardous material must be used to be placed in the mouth. TPU allowed the device to be biosafe when used in the mouth and cleaned.¹³ The device also needed to be smooth and flexible to prevent risk of injury to the mouth. This also allowed the device to be flexible in a way that other materials, such as polylactic acid (PLA), were not.

Device Iterations



Fig 3: Diagram of Device Iterations. The following diagram chronologically displays iterations of the device (from top to bottom) culminating in the final design and prototype.

The first prototype of the device most closely resembles an OPA. This iteration slightly lessened the length of the arch on the OPA which was meant to gather the tongue so that it would not approach the epiglottis and cause a gag reflex. Additionally, the design placed a heavy emphasis on maintaining the structure of the mouth with a large arch that conceals two tubes running the length of the device. The tubes would be attached to a nasal cannula.

The second iteration of the device demonstrates the novel design philosophy selected for the device going forward. From this iteration onwards, all concepts/prototypes feature channels running along the sides of the arch where the oxygen and CO2 tubing is guided to the back of the mouth. Furthermore in order to minimize chances of a gag reflex, a slight angle was applied to the arch's termination.

The third iteration of the device takes dramatic steps to ensure a discreet profile to minimize invasiveness and facial distortion. This is done through shrinking the arch of the device as well as changing the size and shape of the dental plate (see Figure 6 in Materials & Methods).

The final iteration of the device maintains the same general shape of the iteration three but is shrunken.

All iterations of the device were 3D-printed at the UVA Robertson Media Center (RMC) using a Lulzbot Taz-6 Flexistruder running TPU filament.

Mechanical Testing

In order to test the efficacy of our final prototype, a mechanical test was conducted to ensure the device could withstand the forces of the mouth while in the surgical environment. Six prototypes were split into two groups and these samples were then placed under a compression instron. Their strain vs stress data is plotted below in Figure 4. Differences in the bulk modulus between each prototype were found to be non-significant after a one-way ANOVA test ($p = 0.2310$).

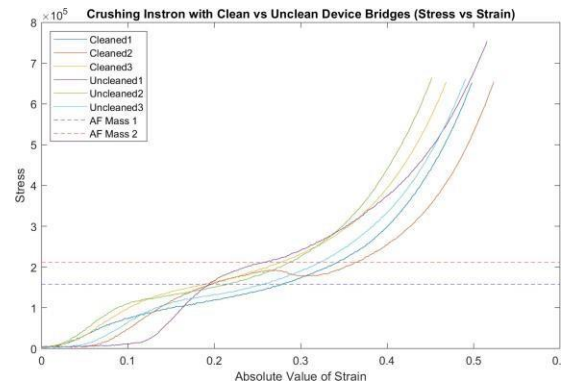

Fig. 4: Mechanical Testing Results. Stress-strain curves used to determine the compressive modulus of each individual device bridge. Dotted lines represent the different masses used in airflow testing.

Air flow Testing

Air flow testing was performed via the schematic shown in Figure 7 in the Materials & Methods section. The graph below in Figure 5 shows the results of that testing:

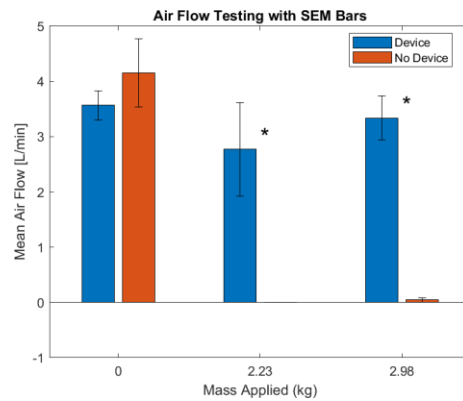

Fig. 5: Air flow testing results. Asterisks demonstrate significant differences in the results between pairs of device (blue) and no device (orange) trials grouped by tested mass. There was no significant difference in the air flow between mass groups for device trials. This demonstrates that the device was able to maintain air flow comparable to a naked cannula line with up to 3 kg of mass placed upon it and maintained air flow where a standard cannula line could not.

These results demonstrate the ability of the novel device to maintain air flow comparable to

a naked cannula line in mass conditions that would completely arrest air flow when placed upon an unsupported cannula line. The mean flow rates for each trial were tested for statistical significance via a Student's *t-test*. P-values are listed in Table 1 below:

Trial #	1	2	3
Device vs No Device	0.4349	0.0105	0.0010
Device vs Trial 1	x	0.5497	0.6801
Device vs Trial 3	0.6801	0.7519	x

Table 1: Air flow testing p-values. This table lists the p-values for various combinations of air flow means as derived from a Student's *t-test*. The "Device vs No Device" row lists p-values derived from a *t-test* of the mean air flow rate values of each device-no device mass condition pair. The "Device vs Trial 1" row lists the p-values derived from comparing mean air flow rates from the listed trial against Trial 1, both with devices. The "Device vs Trial 3" row is as the previous row but each Trial compared against Trial 3 with device, which is the first value of this row is the same as the final value of the previous row.

Discussion

Interpretations of Results

The device was able to satisfy the aforementioned constraints, as verified by the expert opinion of listed advisors.

The mechanical testing via crushing Instron was able to demonstrate that the method of cleaning the device for oral safety did not significantly alter the bulk modulus of the device. This shows that this method maintains the strength of the primary loading section of the device which is necessary to maintain air flow. Additionally, via visual inspection, each bridge (as seen in Figure 6) was able to return to its original form regardless of the total strain that bridge underwent.

Determining if the device lost strength due to cleaning was paramount. The cleaning method of warm water and dish soap was necessary to clean the device to maintain patient safety. It was not necessary for the cleaning method to sterilize the device, as the mouth is not a sterile environment and traditional OPAs used by the anesthesia team are not sterile. As the purpose of the device is to provide a shell for the nasal cannula line in the mouth to prevent obstruction, if the required cleaning method caused a significant loss in strength, this could have disqualified TPU as a usable material. The cleaning method did not alter the bulk modulus of the device and thus TPU was able to be used as the construction material.

From the visual inspection done after the mechanical testing, it was found that the bridges would revert back to their original shape even after experiencing high force levels. While the nasal cannula is typically a single-use medical device, the ability of the adaptor to retain its shape after being exposed to high forces means the adaptor can experience multiple forces throughout a surgery (e.g. biting by the patient multiple times) without deformation. As there was no statistical difference in the mechanical properties between a clean vs unclean adaptor, this means that the adaptor can be used in a surgical setting for multiple procedures.

Air flow testing demonstrated that the device did not significantly reduce air flow relative to a naked cannula line. Furthermore, it was able to maintain this air flow rate under massed conditions where a naked cannula line would completely arrest air flow due to an applied mass. This was necessary to demonstrate the purpose of the device to protect the cannula line potentially under massed conditions. If the device significantly reduced air flow relative to the naked cannula line or did not sufficiently maintain air flow under massed conditions, the design would have been disqualified.

The nasal cannula target oxygen flow rate is usually set between two and four L/min, as if a patient requires more oxygen, a more advanced oxygen assistance device is required.¹⁴ The airflow testing showed how using the device allowed the cannula to stay in this range, only slightly dipping in comparison to a cannula only flow rate when there was no weight. The two additional weights chosen were 2.23 kg and 2.98 kg. These weights correspond to forces near the beginning and end of the bulk modulus found in the mechanical testing, and are visualized as the dotted lines on the strain vs stress plot in Figure 4.

Given these results, the device met the intended goals as it was able to protect air flow under conditions where it would be arrested under current practices. Device strength is maintained when cleaned. Air flow is not worsened by using the device and protected when placed under mass, as compared to current practices.

Limitations

The avoidance of facial obstruction and distortion was verified by the expertise of the advising surgeons. A quantifiable survey of a larger number of surgeons regarding this matter was not conducted.

Air flow testing was only performed under two mass conditions, up to 3 kgs of mass, which is below the human maximum.¹⁴ This constraint comes from the materials available to the researchers when designing the air flow testing procedure. The maximum does not necessarily need to be tested as a patient undergoing MAC would not likely bite with full force upon the device in practice.

Possible Experimental Improvements

A survey of a wider body of surgeons to gauge expert opinion as to the avoidance of obstruction and tissue distortion could be conducted. This would provide more substantial evidence as to the device's ability to meet this qualification.

Performing air flow testing with a larger range of masses until air flow is significantly reduced or completely suspended could be performed to determine the limitations of the device. Measuring up to human bite force may not be necessary, but would provide useful information as it would represent the bounds of force this device would experience in practice.

Due to the lack of budget much of the prototyping and testing of the devices was highly limited, causing slightly lower quality data and resource limitations. Given a larger budget in the future more accurate equipment could be used to gather data on the device. Additionally the devices could be fabricated more uniformly and to a higher standard with better machinery than was available at the RMC.

Next Steps

Given the final goal of pushing the device to market, the next steps of this project are aimed at filing a patent application. This will protect the device's design as it begins the final steps of testing. Additionally, while the device is theoretically functional, it lacks any rigorous testing from the OR. As such an Institutional Review Board (IRB)-approved study will be completed to verify the device is effective in practice.

Materials & Methods

Creation of the Prototype design

Given the experience of both the undergraduate engineers and the physicians involved in this project with both iterative design using AutoDesk Fusion360 and additive manufacturing in the form of 3D printing, these tools were utilized for the design and manufacturing portion of the project. Prototypes of the various iterations and the final design were printed using TPU and a Lulzbot Taz-6 3D printer at the UVA Robertson Media Center. Figure 6 shows a final prototype of the adaptor.

TPU was chosen as the fabrication material because it's safety once cleaned, flexibility, and comfort in the mouth. Once washed, TPU is a safe material to be used with the body. TPU is uniquely flexible among accessible fused deposition modeling (FDM) materials which is

beneficial as it allows for a variety of tooth curves to be accommodated by the wings and dental plate. The comfort of TPU comes from its relative softness as compared to PLA, another common FDM material which is stiffer with harder edges. As such, TPU is the preferred material for this device.

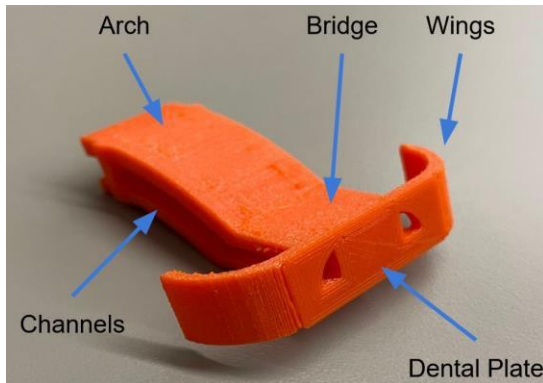

Fig. 6: Picture of final prototype with labels of individual sections. This image shows the individual parts of the device including the arch, bridge, channels, dental plate, and wings.

Mechanical Testing Setup

In order to determine whether or not the mechanical properties of the device would withstand forces generated within the mouth, as well as whether or not those properties would be changed by cleaning, a test was devised using an instron machine. Six prototype devices were fabricated and had the bridge section isolated. Three of the bridges were cleaned thoroughly using dawn dish detergent while the other three were left untreated.. Afterwards the bridges were all crushed to failure under an instron one at a time. The stress-strain data was then uploaded from the instron and graphed via matlab as seen in Figure 5.

Airflow Testing Setup

In order to compare the functionality of the device under forces experienced in the mouth to the current practice,, a novel air flow testing procedure was created for this project. The *Bunch O Balloons Portable Party Balloon Electric Air Pump Starter Pack*, which

includes a balloon pump and balloons, was acquired from Walmart. One two-gallon bucket, two one-and-a-half liter buckets, one $\frac{3}{8}$ inch dowel rod, and 3M Black Rubberized Duct Tape were bought from Lowes. Weights, a ruler, and a scale were already found in the lab.

The balloon pump was connected to the nasal cannula line, passed through the device, and attached to the balloon. The balloon was then attached to the bottom of the 2 gallon bucket and the bucket was then filled with water. By activating the pump, the balloon was inflated and the resulting change in water height was used to calculate the change in volume of the balloon during inflation. The balloon's inflation time was recorded in order to calculate the rate of airflow through the nasal cannula tubes. Three different masses were chosen to test the airflow under: 0 kg, 2.23 kg, and 2.98 kg. To add the force, the dowel was placed on the bridge of the device, with a 1.5 liter bucket hanging on each side. The buckets were then filled with weights until the required force was reached. The experiment was carried out at all three force levels twice, once when the device was used and once without the device being used. Figure 7 shows a drawing for the setup for the airflow testing.

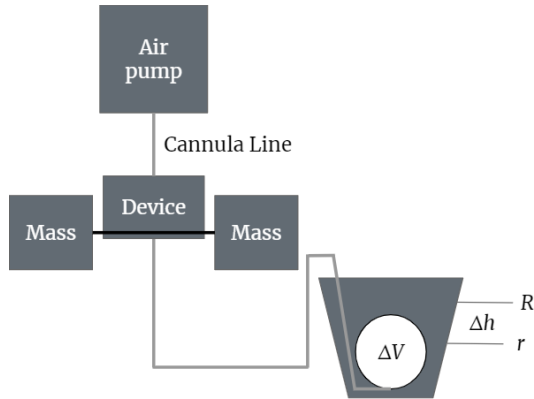

Fig. 7: Schematic of Airflow Testing Setup. This image shows a schematic of the novel air flow testing method. The device is weighed down by the masses to simulate the biting force. The air flows to the balloon secured to the bottom of a partially filled water bucket. As the balloon expands, the water level rises allowing for the measurement of the change in volume and, when timed, air flow rate.

The equations used to calculate the airflow based on the water volume are shown below. As the bucket was a section of a conical cylinder, Equation 2 was used to calculate the volume at the beginning and end points, where R represents the bucket radius at the final water height and r the bucket radius at the initial water height.

Equation 1:

$$\Delta V_{\text{balloon}} = \Delta V_{\text{through device}}$$

Equation 2:

$$\Delta V = \frac{1}{3} \pi \Delta h (R^2 + Rr + r^2)$$

Equation 3:

$$Q_{\text{flow rate}} = \frac{\Delta V}{t_{\text{test duration}}}$$

End Matter

Author Contributions and Notes

Epps, M., Hassan, K., Sande, W. created CAD designs, constructed prototypes, designed testing procedures, collected data and wrote the final report.

The authors declare no conflict of interest.

Acknowledgements

The capstone team would like to thank Dr. Samuel Oyer, MD, Dr. Claudia Gutierrez, MD, Dr. Rachel Jonas, MD and Andrew Zaininovich from the UVA Facial Plastic & Reconstructive Surgery Department of Otolaryngology for advising the team throughout the development of the device. The team would also like to thank Noah Perry and Dr. Shannon Barker from the UVA Department of Biomedical Engineering for advising throughout the project.

References

1. Kugler, T. & Reconstructiv, A. A. of F. P. & American Academy of Facial Plastic and Reconstructive Surgery. *American Academy of Facial Plastic and Reconstructive Surgery* <https://www.aafprs.org/>.
2. Ghisi, D., Fanelli, A., Tosi, M., Nuzzi, M. & Fanelli, G. Monitored anesthesia care. *Minerva Anesthesiol* **71**, 533–538 (2005).
3. Bitar, G. *et al.* Safety and efficacy of office-based surgery with monitored anesthesia care/sedation in 4778 consecutive plastic surgery procedures. *Plast Reconstr Surg* **111**, 150–156; discussion 157-158 (2003).
4. Taub, P. J., Bashey, S. & Hausman, L. M. Anesthesia for Cosmetic Surgery. *Plastic and Reconstructive Surgery* **125**, 1e (2010).

5. Jaisani, M. R., Pradhan, L., Bhattarai, B. & Sagtani, A. Intubation Techniques: Preferences of Maxillofacial Trauma Surgeons. *J Maxillofac Oral Surg* **14**, 501–505 (2015).
6. Prathigudupu, S. *et al.* Mortality in Maxillofacial Trauma-A Review. (2018) doi:10.21276/sjodr.2018.3.7.3.
7. Diamond, L. Managing epistaxis. *JAAPA* **27**, 35–39 (2014).
8. Tabassom, A. & Cho, J. J. Epistaxis. (2022).
9. Childers, C. P. & Maggard-Gibbons, M. Understanding Costs of Care in the Operating Room. *JAMA Surgery* **153**, e176233 (2018).
10. Shantha, T. R. & Wieden, R. Lower jaw thrusting, mandibular protracting, tongue holding, universal oropharyngeal airway device. (2021).
11. Diorio, M. P. Oral cannula. (2008).
12. Thomas, N. Oropharyngeal airway device. (2022).
13. Vogels, R. R. M. *et al.* Biocompatibility and biomechanical analysis of elastic TPU threads as new suture material. *J Biomed Mater Res B Appl Biomater* **105**, 99–106 (2017).
14. Wiersema, U. F. Chapter 28 - Noninvasive Respiratory Support. in *Cardiothoracic Critical Care* (eds. Sidebotham, D., Mckee, A., Gillham, M. & Levy, J. H.) 410–418 (Butterworth-Heinemann, 2007). doi:10.1016/B978-075067572-7.50031-X.