

# Hydroponic Crop Cultivation (HCC) for Food Security in Small Island Developing States

Shayne Cassidy, Matthew Coulter, Thomas Finkelston, Klara Hoherchak,  
Antonio Vaz Raposo Mendes de Almeida, Griffin Ott, Colin Patton, Kaila Stein  
University of Virginia, sc5za, mwc9ed, tjf3aj, klh7mp, arm4uc, gno2by, cp5sb, ks5wt@virginia.edu  
Faculty Advisors: Bevin Etienne, Manuel Lerdau, Garrick Louis

**Abstract** - The Atlantic hurricane season brings devastation to Small Island Developing States (SIDS) each year. SIDS, as designated by the United Nations, are developing countries with specific vulnerabilities due to their small size and susceptibility to environmental disasters [1]. These disasters have led to episodic food insecurity and disruption of agricultural livelihoods. In order to address this problem, a 3-Cavaliers research group at the University of Virginia partnered with Babylon Micro-Farms (BMF), a company in Charlottesville, VA, to develop a hydroponic crop cultivation (HCC) system for use in the Caribbean as a test case for SIDS. Hydroponics refers to the cultivation of plants through a nutrient rich solution without the need for soil. The research team worked with previous Capstone teams to develop and test a low-cost HCC system in the island of Dominica after Hurricane Maria. The current Capstone project aims to enhance this design by strengthening its resilience to storms and hurricanes.

The resulting hydroponics system design for SIDS has four main parts: the plant growth unit, the nutrient water system, the solar power unit, and the structure. The plant growth unit is made up of PVC pipes that are on a top base and covered by an agricultural fabric to protect from insects. This base is angled to initiate the gravitational flow of the nutrient enriched water that is pumped in by the system. The solar power unit provides power to the system of pumps that move the water and nutrients throughout the system. The plant growth unit is supported by a collapsible wooden frame to reduce wind loading on the structure. Once the structure is collapsed, a durable plastic cover can be pulled over the unit to further protect the plants from wind. Both the plant growth unit and the base of the structure are designed to be easily transportable so users can safely store the unit inside during intense storms.

Ultimately, we will create blueprints of the structure and design plans for a prototype that will be used and monitored in Abaco, Bahamas. We will also deliver a conditional recommendation on which crops to grow with respect to five specific criteria: harvest period, yield, seed price, market price, and nutritional value. This will allow the farmer to determine his

**particular crop species based on his own unique goals for hydroponic farming.**

*Index Terms* – process improvement, environmental systems (e.g. water, energy, LCA, etc.), decision analysis, disaster relief, hydroponic crop cultivation

## MOTIVATION

Hurricane Dorian was one of the most devastating natural disasters to ever come out of the Atlantic Ocean. The Category 5 storm touched down in the Bahamas on September 1<sup>st</sup>, 2019 and ravaged the island for two days. While the shocking death toll and damage estimate numbers were heavily publicized, a much less touted fact was that 60,000 people on the island were in need of immediate food relief [2]. Organizations like the World Food Programme attempted to help by airdropping 14,700 individual meals-ready-to-eat (MREs), but this was merely a temporary solution to the serious problem- that both food stores and agricultural fields had been largely wiped out [3]. Food security is one of the most difficult and pressing issues to solve within a community attempting to recover from a natural disaster. SIDS– characterized by small size, isolation, and susceptibility to natural disasters – face a unique, periodic food security challenge following traumatic events like Hurricane Dorian. Many SIDS are highly dependent on food imports, with some countries importing almost 95% of their food and beverages [4]. This exacerbates the food security challenge during hurricanes and increases the need for a resilient food supply in SIDS.

A potential solution to this problem could be found in hydroponic crop cultivation (HCC), which is a method of growing plants without soil by instead using a nutrient-rich solution. HCC is one method to decrease the risk that SIDS face from hurricanes, as it produces crops using 90% less water and 75% less land space than conventional crop cultivation (CCC) in soil [5]. HCC gives the farmer more control over growing conditions such as light, water, nutrients, and temperature. This means crops can be grown in areas with low soil fertility, limited farmland, or even on floating farms. This method of agriculture has proven effective on both small and large scales.

HCC can provide livelihood for farmers and supplement food supplies in SIDS, especially in the aftermath of hurricanes and other natural disasters, which

would strengthen food security and add resilience to the food supply in SIDS.

### **KEY STAKEHOLDERS AND THEIR ROLES**

There are multiple key stakeholders in this Hydroponic Crop Cultivation project. These include Babylon Microfarms (BMF), the Bahamas Ministry of Agriculture (BMA), The Bahamas Agriculture and Marine Science Institute (BAMSI), Firehouse Spice Company (FSC), local farmers, and residents in emergency shelters in Abaco.

BMF is a Charlottesville based startup that creates hydroponic units for commercial use. Individuals, restaurants, or hotels can purchase a 15-ft<sup>2</sup> micro-farm that is advertised to equate to approximately 2000 square feet of farmland. With the micro-farm, BMF reports that consumers can grow 5800 plants per year, with 95% less water and food waste, 94% less fertilizers, 99.9% less transportation, and 71% less carbon emissions. Consumers enjoy the product because it represents a greener alternative to growing crops. BMF's role in the project is to supply us with the nutrients, pre-seeded trays, and their feedback-control nutrient concentration system for our unit. This system will allow for the optimization of crop yields within the HCC unit by continuously measuring the nutrient concentration to ensure that the crops receive the optimal quantity of each nutrient, as each crop needs a specific concentration of various essential nutrients. BMF is committed to the project as they believe that their experience and product can complement our project to accomplish the goal of aiding disaster relief as well as contributing towards the growth of small farming communities.

Through the implementation of our HCC system, the Bahamas will improve resilience of their food supply methods, which will provide for a faster response time when a disaster strikes. The Bahamas Ministry of Agriculture (BMA) will help facilitate the integration of HCC into agricultural practice in the Bahamas as well as supplementing food supplies to emergency shelters. Our project will aid the BMA by increasing the presence of modern technologies and farming methods to their agricultural industry, ultimately helping to restore agricultural production in Abaco.

Local farmers and the inhabitants of Abaco will benefit from our HCC system and its year-round safe food supply that has the ability to resist most expected disasters. This reliable harvest will stabilize farmer incomes and allow them to enter into supply contracts because of their predictable crop production. We expect annual financial gains from growing crops in our unit to offset the opportunity cost of using the area it occupies for CCC. The role of the farmers is to adopt our system and provide feedback on the unit.

Additionally, to gain a better understanding of the marketplace and the harvests from hydroponic farmers, we consulted the Bahamas Agriculture and Marine Science

Institute (BAMSI). While they operate in North Andros, Bahamas, their operations have seen success and they relayed a good template to bolster our comprehension. We also consulted Firehouse Spice Company (FSC), an agricultural services company that produces value-added agricultural products in the Bahamas. FSC also promotes entrepreneurship by women in the Bahamas agricultural sector.

### **GOALS AND OBJECTIVES**

The main goal of the project is to design a prototype for a fold-out, microgrid-supported hydroponic unit, which will help introduce hydroponic technology to SIDS as well as provide a consistent food supply for local inhabitants, especially in the aftermath of a natural disaster.

We have several objectives that guide our research and support our main goal. The first is to ensure that the hydroponic system can be feasibly built and maintained by a group of farmers in the Bahamas. To achieve this objective we have worked to locate local materials that can be used for construction. Because the cost of shipping materials internationally is extremely high, we decided it would be optimal to use as many locally sourced materials as possible. Additionally, we created helpful user diagrams so that farmers can have a visual point of reference.

Another objective for our project is fostering the ability to observe and collect data on how the system performs once it is up and running. To achieve this goal, we have developed relationships with helpful personnel, who will aid us in collecting user and performance data. Areas of focus will include crop yield, financial returns for farmers, and documentation of issues with the design. We also hope to discern what market opportunities exist for these hydroponic goods.

Additionally, a major objective of the project is to gauge interest of local farmers in SIDS in adopting and spreading hydroponic technology. To achieve this task, we researched methods to educate and excite traditional farmers on hydroponics, which will ultimately promote longevity of our project.

## METHODOLOGY

The next step was to design a HCC system that integrates the commercial and dietary needs of the local Abaco farmers with a storm-resistant design necessary to ensure food security. The design was based on many important attributes, including a versatile design, abundant water supply, solar power, and optimal crop selection.

### *Versatile Design*

The structure is designed with storm-resistance as the top priority. After speaking to contacts in the Bahamas, it became clear that the best way to protect plants would be to design a structure that would allow the user to bring the plants indoors during a storm. Therefore, the design focuses on collapsibility and transportability.

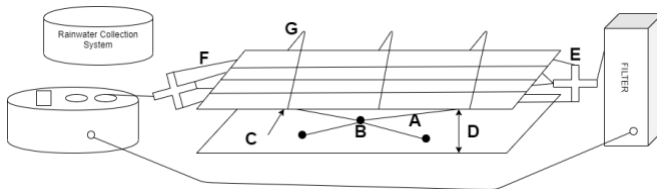

Fig. 1. Side View of Hydroponic System

The standing structure is 3-feet tall, 4-feet wide, and 5-feet long. There are two separable components in the design that are held together by four clamps: the plant growth unit and the support structure. The user is able to quickly remove these clamps (Fig. 1.C) and carry the plant growth unit inside to a safe location. Moreover, when the clamps are removed, the x-shaped legs (Fig 1.A) collapse at the connector point (Fig 1.B). This allows the legs to be fully removed and the top board to be laid flat on the bottom board (Fig. 1.D). The unit is thus lowered to create a compact base that can be easily brought inside. The junction pieces that distribute and collect water (Fig. 1.E, 1.F) are disconnected as well. Once the storm is over, the user can bring the unit back outside and easily reassemble it to immediately continue farming.

In order to address other farming problems, including strong winds and pest intrusion, an agricultural fabric will be installed as a shelter for the plants. Three metal hoops (Fig. 1.G) will be secured around the PVC pipes and plants, providing a protected area for the plants to grow. The pest control fabric will be tightly wrapped around the metal rings, acting similarly to a greenhouse. The fabric will still allow air to flow throughout the system but will partially protect the plants from pests. The fabric will also reduce the amount of rain water entering the system. This is an important aspect as hydroponic farming is focused on providing plants with the optimal quantity of specific nutrients and water.

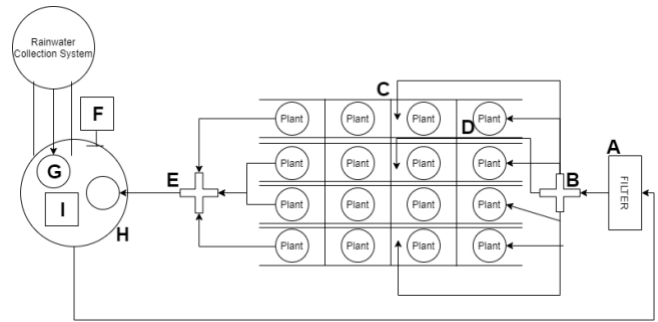

Fig. 2. Top View of Hydroponic System

The unit is also designed to maximize crop yield. By creating four channels (Fig. 2.B) from filtered water (Fig 2.A), the nutrients are spread out more evenly among the plants, thus improving on the previous design. Once the water flows through the filter and into the PVC pipe channels, the nutrient enriched water will flow through each plant's roots (Fig. 2.C, 2.D) to the end of the base unit. Similarly to the junction connected to the filter, the excess nutrient water will be collected at the bottom of the pipes (Fig. 2.E) and dispersed back into the barrel. If there is insufficient water supply, the "Rainwater Collection System" can also be used to fill up the tank (Fig. 2.G).

Finally, water is pumped back to the filter utilizing a solar-powered pump (Fig. 2.H) that lies inside the system. The power for the system comes from the auxiliary solar panel that can input the energy into the system at top of the barrel (Fig. 2.I). Using the controller (Fig. 2.F), the hydroponic user can decide how to distribute the solar energy collected. With the water pumped back into the filter, the process repeats itself.

### *Abundant Water Supply*

The water supply for the unit can come from a variety of sources. In normal conditions, the user can fill the nutrient barrel with water from their house connection, a well, or another water source. If there is a disruption to the site, such as a pollutant or pathogen in the water supply, or saltwater intrusion, the user can connect the nutrient barrel to a rainwater collection system and use rainwater to water their plants. It is important that the water supply is clean in order to produce safe, healthy crops. In addition, there is a slow sediment filter that can filter out harmful particles in order to make the water potable in an emergency situation. This enhances the quality of the water not only for the plants, but also for humans if they need an emergency water supply.

### *Utilizing Solar Power*

During the hurricane season in SIDS, the grid power system can be unreliable and is susceptible to frequent power outages. After large storms, the typical grid

power system on these islands can be out for months at a time, leaving the locals to resort to alternative energy sources. For our unit we looked into solar, wind, and gas as potential power sources. Using a multi-criteria selection methodology, we ruled out wind due to scalability and gas due to cost and dependency issues, leading us to solar power. With many SIDS farmers already making the switch to solar, it was clear that this type of renewable energy would work well in this environment and allow for the unit to be removed from the unstable island power grid.

Moving forward with solar energy, we determined the output our solar energy system would need to produce in order to power the essential items within the system. As part of our goal to make the unit serve as emergency relief, beyond that of a supplemental food source, we identified the items that would require power as the following: water pump, phone charger, miniature refrigeration system for medicine, and emergency lights. With these items identified, we were able to identify the power usage of the unit in emergency scenarios and begin planning out a solar energy system capable of supporting it. The preliminary design for the solar system architecture to support this includes a 0.8 kW PV array, 4 Trojan L16P battery, 1.5 kW inverter, and a 1.5 kW rectifier. Figure 3 shows the expected kW production of this system on a monthly basis based on the weather patterns in the Caribbean region.

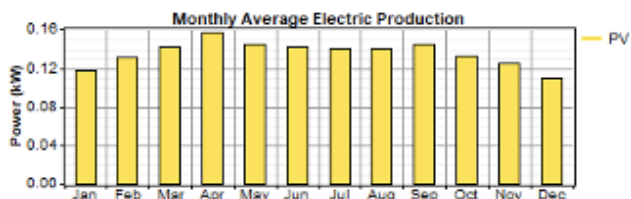

Fig. 3. Monthly Average Electric Production

### Optimal Crops

We also performed analyses of different types of crops in order to ascertain which would be optimal to grow in the hydroponic farm. The ideal, or “golden,” crop is both highly nutritious and commercially valuable, thus making it suitable in emergency relief efforts as well as standard market dealings. Other specific criteria noted for a valuable hydroponic crop include harvest period, yield per square foot, market price, seed price, and nutritional value. Both leafy green vegetables and solanaceous crops present specific advantages and disadvantages when considering their viability both in this project specifically and in hydroponic crop cultivation in general.

The team constructed an excel spreadsheet to provide a conditional recommendation on which crops to grow. The spreadsheet reflects the scoring and ranking of different crop alternatives, in which both the raw data and corresponding normalized values for each criteria are included, as well as attribute weights, final score, and rank.

Two different weighting methods were used to compute each crop’s final score value: one utilizing weights based on each user’s personal preference, and a second weighting method employing additive weighting. The primary difference between the two is that the differing ranges of the criteria are accounted for in the latter method in order to prevent the wide discrepancy in ranges from excessively affecting the final scoring outcome. No alteration of the weights is required in the second weighing method; however, the user may change the raw data for either of the weighing methods if he or she discovers new information, and the scores and ranks will automatically update within the excel spreadsheet. The final scoring table for additive weighting is shown below in Table 1.

	Harvest Period	Yield	Seed Price	Market Price	Nutrition	Score	Rank
Bell Pepper	49	9	0	1	92	55.62	2
Tomato	0	100	0	9	100	59.51	1
Basil	100	0	98	100	0	40.88	3
Romaine Lettuce	28	17	100	0	40	33.47	4

Table 1. Golden Crops

After normalizing attributes and using additive weighting, the score attributes were calculated. It is important to note that the physical number of the score has no underlying meaning aside from representing the results of the analyses. These results concluded tomatoes as the best overall crop, bell peppers second, followed by basil, then romaine lettuce. However, the final recommendation may differ depending on the weights assigned to each attribute, and thus will ultimately reflect the needs of each specific farmer.

### CONCLUSION AND FUTURE WORK

Our design for a microgrid-supported and storm-resistant hydroponic unit will greatly increase the capacity of SIDS to adequately respond to natural disasters. Some limitation of our work is that the device is still in the design stage. While we have a comprehensive plan for building the prototype, the actual construction of the hydroponic unit has yet to be completed. This will likely be the focus of future work, as building the hydroponic system will allow for issues to be resolved as they develop and thus bring the unit closer to in-field deployment.

The development of hydroponic agriculture within SIDS will allow those communities to reclaim food independence while insulating themselves from the disastrous effects of hurricanes on the food sector. Our proposed design is particularly effective due to its storm-resistance, as it can be counted on as a source of emergency food supply in the immediate aftermath of a disaster. While there is still work to be done, our team’s efforts represent a significant step in the right direction toward a self-sustaining future for the farmers in SIDS.

## ACKNOWLEDGMENT

**Babylon Micro-Farms**, Charlottesville, VA.

**Bahamas Agriculture and Marine Science Institute**,  
North Andros, Bahamas.

**Firehouse Spice Company**, North Andros, Bahamas.

**Leonard Githinji**, Professor, Virginia State University.

**Murphy International Development**, Georgetown, CT.

**Funding for this project was provided by a University of Virginia 3 Cavaliers grant.**

## REFERENCES

- [1] "The Future we want: Rio 20: United Nations Conference on Sustainable Development, 20-22 June 2012, Rio de Janeiro, Brazil," in *The Future we want: Rio 20: United Nations Conference on Sustainable Development, 20-22 June 2012, Rio de Janeiro, Brazil*, 2013.
- [2] P. Beaumont, "Hurricane Dorian destruction set to cost Bahamas 'up to billions'," *The Guardian*, 04-Sep-2019. [Online]. Available: <https://www.theguardian.com/world/2019/sep/04/bahamas-reels-hurricane-dorian-damage-cost-hundreds-millions>. [Accessed: 09-Apr-2020].
- [3] "Hurricane Dorian: WFP Support to the NEMA/CDEMA-led humanitarian response in the Bahamas Situation Report #02, 06 September 2019 - Bahamas," *ReliefWeb*, 06-Sep-2019. [Online]. Available: <https://reliefweb.int/report/bahamas/hurricane-dorian-wfp-support-nemacdema-led-humanitarian-response-bahamas-situation>. [Accessed: 09-Apr-2020].
- [4] Food and Agriculture Organization of the United Nations, "Excessive food imports threaten SIDS economies," *FAO Site*, 2008. [Online]. Available:

[http://www.fao.org/newsroom/en/focus/2005/1000142/article\\_1000149en.html](http://www.fao.org/newsroom/en/focus/2005/1000142/article_1000149en.html). [Accessed: 09-Apr-2020].

- [5] Savvas, D. (2003, January 24). *Hydroponics: A modern technology supporting the application of integrated crop management in greenhouse*. Retrieved April 9, 2020, from <https://pdfs.semanticscholar.org/b334/0b0d3ac38b219eac05e3390dc680f0d47741.pdf>

## AUTHOR INFORMATION

**Shayne Cassidy**, Student, Department of Engineering Systems and Environment, University of Virginia.

**Matthew Coulter**, Student, Department of Engineering Systems and Environment, University of Virginia.

**Thomas Finkelston**, Student, Department of Engineering Systems and Environment, University of Virginia.

**Klara Hoherchak**, Student, Department of Engineering Systems and Environment, University of Virginia.

**Antonio Mendes de Almeida**, Student, Department of Engineering Systems and Environment, University of Virginia.

**Griffin Ott**, Student, Department of Engineering Systems and Environment, University of Virginia.

**Colin Patton**, Student, Department of Engineering Systems and Environment, University of Virginia.

**Kaila Stein**, Student, Department of Engineering Systems and Environment, University of Virginia.