

**SurePace Walker: A powered walker for children with cerebral palsy**

A Technical Report submitted to the Department of Biomedical Engineering

Presented to the Faculty of the School of Engineering and Applied Science  
University of Virginia • Charlottesville, Virginia

In Partial Fulfillment of the Requirements for the Degree  
Bachelor of Science, School of Engineering

**Albert Keynes Mendoza Roldan**

Spring, 2022

Technical Project Team Members

Gabrielle Fuller

On my honor as a University Student, I have neither given nor received unauthorized aid on this assignment as defined by the Honor Guidelines for Thesis-Related Assignments

Gene Parker, PhD, Merrick Furman, Barron Associates Inc.

# SurePace Walker: A powered walker for children with cerebral palsy

Gabrielle M. Fuller<sup>a1</sup>. Albert M. Roldan<sup>a</sup>

<sup>a</sup> University of Virginia

<sup>1</sup> Correspondence: gmf6cc@virginia.edu

## Abstract

The SurePace Walker is an intelligent powered walker designed to assist children with cerebral palsy. Using data acquired from an array of motion sensors, an onboard computer with a predetermined algorithm determines optimum power output to the rear wheels via attached motors to move the walker forward to decrease energy expenditure by the user. The end result is providing the user with a greater range and ease of mobility while still maintaining their proper posture. This allows for the user to participate in daily activities more proactively without the burden of pulling a walker around. The goal of this project is to take the functional prototype walker and redesign it into a cohesive device ready for manufacturing, while compiling the necessary documentation to apply for Food and Drug Administration (FDA) Premarket Notification (PMN). The redesign had a few focuses: 1) create a new walker body that integrates all necessary components of the prototype, 2) prepare the design for large scale manufacturing, and 3) improve the aesthetics of the overall product.

Keywords: medical devices, cerebral palsy

---

## Introduction

Cerebral palsy (CP) is a broad term for a number of disorders that affect someone's ability to maintain balance and posture and move around. CP is caused by abnormal brain development or damage to the developing brain. It is the most common motor disability seen in children.<sup>1</sup> Because of the difficulty with movement that results from CP, children with CP often use a walker or a wheelchair. Walkers come in a variety of shapes and sizes, but the one of interest here is the posterior walker. This type of walker follows behind the user and provides support while helping the user maintain balance and an upright posture, rather than bending over an anterior walker, like one commonly used by the elderly. The posterior walker is used commonly by children with CP, both as an alternative to the wheelchair and as a method of physiotherapy. However, as the child already has poor muscle tone, they can tire quickly and easily dragging around this walker. Barron Associates has previously developed an intelligent powered posterior walker for children with CP.

The powered walker has motorized rear wheels and mounted cameras, located at the waist and ankle level. The cameras monitor the user's torso and foot movement pattern to provide information to an onboard computer. The

computer then applies an algorithm which supplies an appropriate amount of power to the wheels to assist the user with walking, allowing them to move as "normally" as possible. While this solution is functional and marketable, there is still room for improvement. The current prototype is very squared off and not aesthetically pleasing. Further, the current prototype is a collection of additions to a commercially available passive walker. If Barron Associates were to proceed to market as is, the walker could go out of production at any time, reverting the project back to square one, as the modifications are walker specific. Further, after some discussion and development, the camera has been switched out for an array of sensors embedded in the back arch of the walker. This choice was made to increase the number of viewpoints from which the algorithm could take data. Rather than just the single view point directly behind the user, looking dead on, the sensor array allows for a variety of angles.

The original prototype was an amalgamation of purchased materials and 3D printed parts. The most important aim of the project was to convert the prototype into a cohesive device ready for manufacturing. For this, SolidWorks was used to develop a CAD model of the walker body while integrating the relevant parts from the prototype.

## **Materials and Methods**

To complete these goals, SolidWorks was used for the walker redesign. SolidWorks is the industry standard CAD software and has built in Finite Element Analysis capabilities in order to test the mechanical properties of the design. Any prototyping of plastic parts would be completed with 3D printing. 3D printing allows for rapid prototyping, which is important due to the time constraints of the project.

The overall design process for the walker redesign involved researching commercially available walkers, identifying key dimensions and materials, and mimicking the overall structure in the design. There is a well-established form of walkers that fits the purpose of the powered walker, so there was no need to stray from the current forms. By mimicking the form and design of commercially available walkers, it was more likely that the final design would lend itself to large scale manufacturing. The most important aspect of the redesign centered around incorporating each additional part into the walker itself, rather than adding it on after the fact, as was done with the original prototype.

## **Results**

The initial prototype of the walker can be seen in Figure 1. The base of the prototype is a purchased rollator, onto which an Intel RealSense depth camera, brushless DC motors, and a Windows based CPU were mounted. The motion sensing camera is back set from the walker in order to center the user in the focal length of the camera. Simple stepper motors were used and attached to the wheels of the walker using a gearbox and a motor mount. The CPU was housed in a 3D printed, water resistant case. The CPU runs on

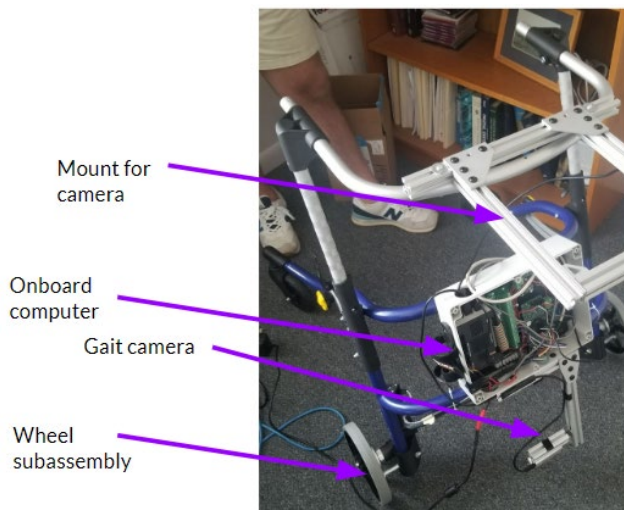
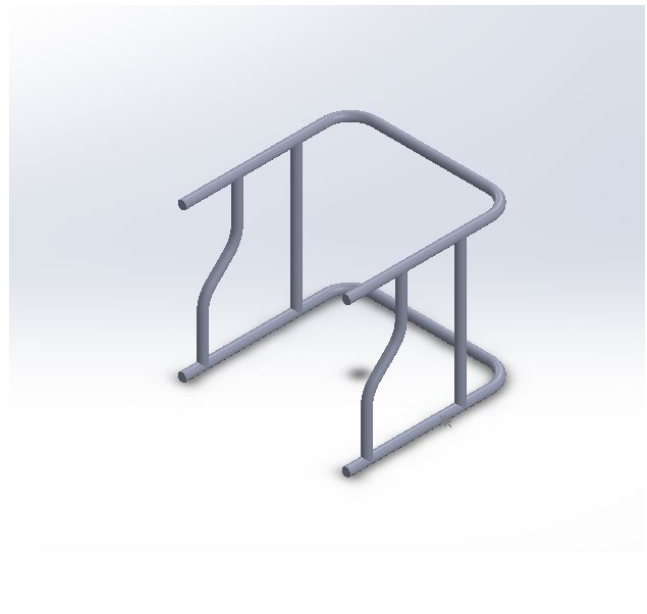

**Fig. 1. Labeled Prototype of SurePace Walker.** The prototype of the SurePace Walker consists of four major added parts labelled here.

Windows and runs the algorithm, which delivers instructions to motors based on the data collected from the motion sensing camera.

The redesign focused on designing a new walker to be made solely for the SurePace walker. Should the device rely on the ability of the manufacturer to obtain the walker base from another company, it makes the entire device dependent on the availability of that walker. If that company were to suddenly stop production of the walker base, the specially designed parts would not be useless. Additionally, by producing a walker solely for SurePace walker cuts production costs as it costs less to manufacture a walker than it does to buy one. Further, the back set motion sensing camera added considerably to the footprint of the walker, making the walker unsuitable for use in smaller spaces, or densely packed spaces (like a school hallway). Eliminating the need to backset the sensors was also a priority. Two aspects of the original prototype that remained unchanged were the motors used and the computer housing. The simple stepper motor was retained, though the housing and mount will need to be modified to fit the new walker design. There were no necessary or desired changes to be made to the computer or computer housing, so those too remained unchanged.

The model for the final design for the new walker can be seen in Figure 2. The overall shape and form of the walker is modeled off of the original base walker, as well as the shapes of other commercially available walkers. The



**Fig. 2. CAD Model of new walker design for SurePace Walker.**

backset camera was abandoned in favor of an embedded sensor array in the back arch. These sensors have a shorter minimum distance that does not require them to be back set, but they are embedded to be flush with the surface of the back arch. Additionally, the body is made of hollow aluminum piping to allow for the necessary wires that connect each component to the computer to be housed internally.

As this is an improvement on an existing technology and an obvious solution, there is no need to pursue the *de novo* pathway through the FDA. Instead, a premarket notification on the 510(k) path will be prepared and submitted, while proving substantial equivalence to a predicate device.

### **Discussion**

Design changes were only made after careful consideration. In regards to the change from a single motion sensing camera to a sensor array, the sensor array allows for multiple angles of data acquisition and makes for a more complete analysis of torso movement. Additionally, as mentioned in Results, it decreases the overall spatial footprint of the walker. In the original prototype, the motors are simply attached to the frame of the walker. This leaves the motors vulnerable to damage, both from water and weather conditions, as well as impacts. Thus, the motors should be encased in a housing that will function to not only protect the motors, but also dampen the noise the motors make while in use. The housing for the motors would not need to be waterproof, just water resistant. The walker is not meant to be used in extreme conditions, nor to be submerged in water, especially regarding the onboard computer. Electronic components only need to be protected from incidental water contact, like that caused by precipitation or splashes.

Overall, the walker should incorporate all wires and sensors to achieve a sleek and clean appearance, the design should be simple such that the manufacturing process is streamlined, and should be no wider than 36 inches. The width restraint corresponds with the standard width of doorways. The sleek and clean design serves a few purposes. First, it improves the overall look and aesthetics of the prototype. Second, it minimizes the risk of disconnection between any and all wired components. Streamlined manufacturing decreases costs. The walker should increase the ability of the user to remain mobile and moving for longer periods of time and reduce fatigue, while increasing walking speed. This will allow for users to have a more normal lifestyle and increase their independence.

The 510(k) premarket notification submission consists of up to twenty different sections, depending on the nature of the device(s) being submitted. In the case of this Capstone project, the main focus was on the four major parts relative to the discussion of the device: the Cover Letter, the Indications for Use Statement, the Executive Summary and Predicate Comparison, and the Substantial Equivalence Discussion.

The purpose of the Cover Letter is to simply introduce the device, the type of 510(k) submission that the submitter is doing, and under what classification, classification regulation, and panel the device should be under. In the case of the SurePace Walker, it falls under the classification regulation of a mechanical walker, which is defined in Title 21 Section 890.3825 of the Code of Federal Regulations (21 CFR 890.3825). Being defined as a mechanical walker means that it holds the product code “ITJ” and falls under the Physical Medicine panel. Due to its powered nature, however, the SurePace Walker would fall under a Class II device, which is why a 510(k) submission is necessary. Additionally, a table that discusses the design and use of the device was also required and is shown in Table 1.

**Table 1. Intended Design and Use of Device**

| <b>Question</b>  | <b>YES</b> | <b>NO</b> |
|--|------------|-----------|
| Is the device intended for prescription use (21 CFR 801 subpart D)?                | X          |           |
| Is the device intended for over-the-counter use (21 CFR 807 subpart C)?            |            | X         |
| Does the device contain components derived from a tissue or other biologic source? |            | X         |
| Is the device provided sterile?  |            | X         |
| Is the device intended for single use?   |            | X         |
| Is the device a reprocessed single use device?                                     |            | X         |
| If yes, does this device type require reprocessed validation data?                 |            |           |
| Does the device contain a drug?  |            | X         |
| Does the device contain a biologic?  |            | X         |
| Does the device use software?  | X          |           |
| Does the submission include clinical information?                                  |            | X         |
| Is the device implanted?   |            | X         |

The Indications for Use statement is a document that outlines the specific conditions that the device will cure, treat, or aid in. The SurePace Walker at the moment is specifically indicated for use for children with cerebral

palsy; however, other possible indications for use were listed as well that covered general mobility impediments that a normal mechanical walker would also assist in.

The Executive Summary and Predicate Comparison gives a more extensive description of the device and restates the indications for use that were listed in the preceding statement. Additionally, this section also begins the discussion of proving substantial equivalence between the SurePace Walker and a “predicate device” that is legally already on the market. This discussion of substantial equivalence is the most essential part of the 510(k) submission, as it shows that a device is similar enough to one already on the market and allows it to bypass premarket approval that would be needed of a *de novo* device. The predicate device chosen for the SurePace Walker was the Child’s Walker created by Kaye Products, Inc. (K833869). The comparison was done in tabular format, which is shown below in Table 2.

**Table 2. Substantial Equivalence Comparison**

| Description              | SurePace Walker  | Child’s Walker (K833869)                                    |
|--------------------------|--|---|
| Indications for use      | - listed above and in Indications for Use Statement                                | - for general use in aiding mobility, regardless of disease |
| Prescription/OTC use     | - prescription   | - OTC and prescription                                      |
| Size(s)                  | - uniform size with adjustable height  | - comes in variety of sizes depending on target population  |
| Target population        | - children with cerebral palsy, other populations mentioned in Indications for Use | - any patient afflicted with impeded movement               |
| Battery or mains powered | - Mains powered with rechargeable battery  | - N/A   |
| Technology/Software      | - onboard computer along with array sensors<br>- software used for gait analysis   | - N/A   |
| Use of Wheels            | - wheels are a primary feature of the walker                                       | - can be used with wheels (rollator) or without             |
| Sterility                | - not sterile, designed for everyday use   | - not sterile, designed for everyday use                    |
| EM Compatibility         | - EM compatible  | - N/A   |

Finally, the Substantial Equivalence Discussion further supplements the tabular comparison between the predicate device and the SurePace Walker. The purpose of this section is to briefly state how the tabular comparison proves substantial equivalence, along with any other bench testing provided with the application, is sufficient to prove substantial equivalence.

**End Matter**

***Author Contributions and Notes***

G.M.F. and A.M.R. contributed to design and modeling. A.M.R. collected FDA requirements, and G.M.F. and A.M.R. wrote the paper.

The authors declare no conflict of interest.

This article contains supporting information online.

***Acknowledgments***

We would like to acknowledge Merrick Furman and Dr. Eugene Parker, as well as the entire Walker team at Barron Associates for their guidance through this project. Further, we would like to thank Dr. Timothy Allen and Dr. Shannon Barker, for their mentorship and counsel in the creation of this report.

**References**

1. Cerebral palsy - Symptoms and causes - Mayo Clinic.

<https://www.mayoclinic.org/diseases-conditions/cerebral-palsy/symptoms-causes/syc-20353999>.

