

3D Printed Stroke Rehabilitation Exoskeleton Design

A Capstone Report
presented to the faculty of the
School of Engineering and Applied Science
University of Virginia

by

Samantha Nicholson

with

Madison DePierro
Keyrim Jung
Abigail Kong
Alex Parson
Carly Thurman
Joel Valentin

May 11, 2023

On my honor as a University student, I have neither given nor received unauthorized aid on this assignment as defined by the Honor Guidelines for Thesis-Related Assignments.

Samantha Nicholson

Capstone advisor: Dr. Sarah Sun, Department of Mechanical Engineering

3D Printed Stroke Rehabilitation Exoskeleton Design

Madison DePierro

*Department of Mechanical and
Aerospace Engineering
University of Virginia
Charlottesville, United States
mrd5ncg@virginia.edu*

Samantha Nicholson

*Department of Mechanical and
Aerospace Engineering
University of Virginia
Charlottesville, United States
srn4pbv@virginia.edu*

Keyrim Jung

*Department of Mechanical and
Aerospace Engineering
University of Virginia
Charlottesville, United States
xvj9dp@virginia.edu*

Alex Parson

*Department of Mechanical and
Aerospace Engineering
University of Virginia
Charlottesville, United States
agp3nc@virginia.edu*

Abigail Kong

*Department of Mechanical and
Aerospace Engineering
University of Virginia
Charlottesville, United States
awk8eup@virginia.edu*

Carly Thurman

*Department of Mechanical and
Aerospace Engineering
University of Virginia
Charlottesville, United States
cmt6xv@virginia.edu*

Joel Valentin

*Department of Mechanical and Aerospace Engineering
University of Virginia
Charlottesville, United States
jzv8qgj@virginia.edu*

Abstract—This document outlines the design, methodology, and evaluation of a 3D printed robotic upper-limb exoskeleton to assist in stroke rehabilitation. This paper provides a general background of strokes and current approaches that helped guide the design of the exoskeleton. It also gives reasoning for the types of sensors, actuators, and motors and their location on the exoskeleton design. Includes designs and test results of a first exoskeleton prototype (V1), testing and improvements made in the second exoskeleton prototype (V2), and the complete two degree-of-freedom shoulder assembly for the third exoskeleton prototype (V3) with test results. The remaining improvements will be outlined for the final exoskeleton prototype (V3) below. *(Abstract)*

Keywords—*stroke, rehabilitation, exoskeleton, DOF, inertial measurement unit (IMU), McKibben pneumatic artificial muscles (PAMs), abduction, adduction, flexion, extension (key words)*

I. INTRODUCTION

A. Motivation and Background

According to the American Heart Association, a stroke occurs in the US every 40 seconds [11]. Patients experience stroke when oxygen and nutrients are blocked from reaching the brain [8]. There are two main types of stroke, ischemic and hemorrhagic. Ischemic strokes have various subclassifications however they stem from a blood clot or plaque blocking or reducing artery flow [8]. Hemorrhagic strokes stem occur when ruptured blood vessels expel excess blood, pooling and pressing up against the brain causing a pressure [8]. As seen in Figure 1, MRI and other imaging studies can detect the occurrence and the severity of a stroke [16].

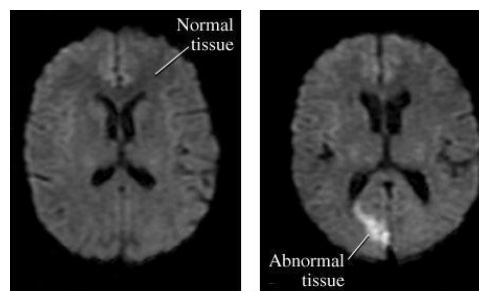

Figure 1

Figure 2

Figure 1: Stroke MRI indicating Normal and Abnormal Brain Tissue [16]

Stroke side effects vary depending on the severity of the stroke and the individual themselves. The NIH stroke scale is one commonly used scale to evaluate the effects of a patient's stroke [27]. Our project focuses on the rehabilitation of a patient's physical abilities. Most patients however experience several common after effects. The two main physical side effects we are concerned with are spasticity and decrease in fine motor skills. Spasticity is involuntary electrical signals sent from the brain to a muscle causing contractions[7]. Contractures can be a more long lasting side effect as it's a form of advanced spasticity that causes muscles to often remain in clenched positions. Figure 2 below demonstrates this in a patient's arm [14]. Patients also experience a loss in fine motor skills [18]. Loss of hand eye coordination and difficulty of controlling their extremities makes it difficult to move cohesively and accomplish tasks.

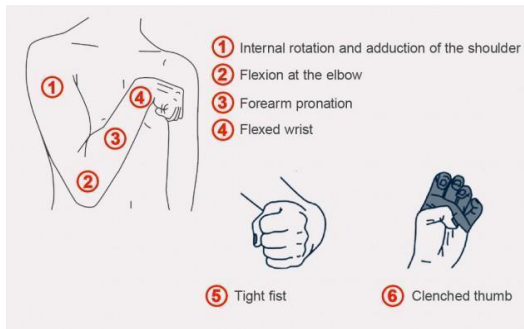
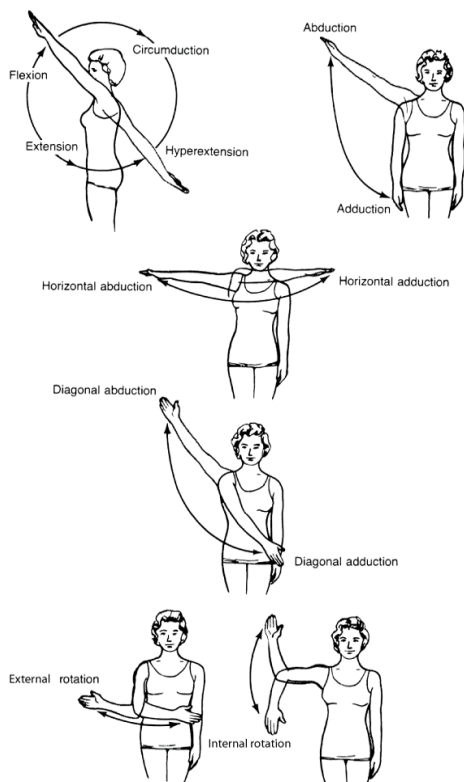

Figure 2: Possible Contractures after Stroke [14]

Focusing on the physical side effects post stroke, Oujamaa's research concluded that in order to recover motor function, a minimum of 25 hours of rehabilitation must be done shortly post stroke [20]. One way of receiving post stroke rehabilitation may be visiting a physical or occupational therapist [25]. Physical therapists use an arsenal of stretches to help reduce muscle stiffness due to spasticity post stroke. Figure 3 below shows several common stretches [12]. Additionally they may assign a patient an active or passive therapeutic exercise program. Patients may also receive mirror therapy. Mirror therapy uses a mirror to reflect a patient's movement of a non affected limb to seem like the treated limb was moving [15].



Source: Hamilton N, Weimar W, Lutgens K: *Kinesiology: Scientific Basis of Human Motion*, 12th Edition: <http://www.accessphysiotherapy.com>
Copyright © The McGraw-Hill Companies, Inc. All rights reserved.

Figure 3: Common Arm Rehabilitative Stretches [12]

B. Literature Review

1) *An Assistive Upper-limb Exoskeleton Controlled by Multi-Modal Interfaces for Severely Impaired Patients: Development and Experimental Assessment [21]*

The goal of this paper was to promote and explain the Bridge Exoskeleton. The purpose of this exoskeleton was to detect movement intention and drive a user's arm in the world space coordinates without performing any muscular forces. In summary, this exoskeleton was created mainly for daily assistance of those with muscular dystrophy with an intended four degrees of freedom for the arm. Specifically, the paper went into detail about many of the specifications including stepper motors, motor drivers, a control unit, a screen, two different human-machine interfaces for motion control, and sensors, such as a joystick and a voice control system [21]. It also went into detail about their anti-gravity system which aided the stepper motors in the process.

2) *Design and Implementation of a Rehabilitation Upper-limb Exoskeleton Robot Controlled by Cognitive and Physical Interfaces [2]*

This paper was more closely related to our design, as well as a good summary of the type of exoskeleton that is envisioned. The purpose of this paper is to explore a rehabilitation exoskeleton that allows flexion/extension of the elbow, flexion/extension of the wrist, and medial/lateral deviation of the wrist. In summary, the paper emphasizes the use of passive therapy control, which is used to strengthen muscles or perform neuromuscular relearning [2]. It also explains how the exoskeleton has a predefined trajectory and is only used for the elbow, wrist, and forearm.

3) *Design and Characterization of a 3D Printed Soft Robotic Wrist Sleeve with 2 DoF for Stroke Rehabilitation [9]*

The goal of this paper was to create a soft robotic exoskeleton for the wrist for stroke patients. This exoskeleton has two degrees of freedom allowing for both rotation and bending of the wrist. Estimated, this exoskeleton allows for approximately 70% of normal range of motion [9]. Instead of a traditional artificial muscle, they used a 3D printed folding actuation muscle. Two muscles are printed and sewed onto opposite sides of a glove then pressurized via air like a traditional artificial muscle. By pressurizing the muscles at different pressures, various angles can be achieved.

4) *Low-Cost 3D Printed Exoskeleton for Post-Stroke Hand Rehabilitation [1]*

This paper designs a 3D printed exoskeleton for finger rehabilitation post stroke. It moves each finger individually by having small actuators attached to steel cables that were attached to rings worn at the end of a patient's fingers [1]. The exoskeleton was driven via an arduino and completely wearable with all electric parts fitting into a housing worn further up the arm. Three main motions were programmed for the exoskeleton including grabbing, pinching, and waving.

The most expensive cost of their exoskeleton ended up being their actuators which accounted for over 90% of their costs.

5) *Design and Kinematic Analysis of a Novel Upper Limb Exoskeleton for Rehabilitation of Stroke Patients, CLEVERarm [5]*

Texas A&M researchers developed a compact, low-weight, ergonomic, virtual reality enhanced rehabilitation arm also known as CLEVERarm. The goal of the CLEVERarm is to provide assistance in the rehabilitation of stroke patients. This exoskeleton has eight degrees of freedom, six are active, however only one is used for flexion/extension of the elbow while the other 5 improve the ergonomics of the arm [4]. In order to keep the weight of the arm minimal, they used 3D printed carbon fiber reinforced plastic and aluminum. The CLEVERarm uses a virtual reality game environment for the patient to visualize limb motion with a variety of tasks [5].

C. Goal and Contribution

From the Bride exoskeleton, it is only used for daily assistance [21]. It cannot be used for rehabilitation. Its sensors are either voice controlled, or the use of a joystick. Our plan is to build a rehabilitation robot designed with a predetermined trajectory that utilizes data from an IMU sensor to regulate its path. The second paper encompasses our vision, but was created for the elbow, wrist, and forearm [2]. We plan to expand upon that by including motion of the shoulder. The low-cost 3D printed hand exoskeleton is also similar to the direction we plan to move in. Their focus is on the fingers themselves while we plan to focus more on the shoulder and elbow. It was interesting, however, to see their 3D printed design and how it was fully wearable with no exterior rack or device needed. Moreover, we will design an exoskeleton that is a combination of these exoskeleton projects. Unlike the third paper, we will opt for more traditional air muscles in our design. Their unique muscle design, while helpful in their scenario, would not work for our large exoskeleton design. The CLEVERarm in the fifth paper also has issues we would like to address with our exoskeleton. The CLEVERarm is slightly bulky and is not fully wearable. It also relies on virtual reality to visualize patient movement, which we will not be using. Our exoskeleton will be a rehabilitation exoskeleton that utilizes an IMU sensor. We will plan to have three degrees of freedom and expand the exoskeleton to include the shoulder. In creating this, we will build an inexpensive rehabilitation exoskeleton for patients who have suffered from ailments that affected their muscular mobility of their upper limbs.

The exoskeleton will be a stroke rehabilitation exoskeleton that utilizes an IMU sensor and has three degrees of freedom, including two degrees of freedom at the shoulder. Ultimately creating a novel, inexpensive rehabilitation exoskeleton for patients who have suffered from ailments that affected their muscular mobility.

D. Research Questions to Guide our Study

To further guide the research we will be carrying out for the study, we have developed research questions to investigate. First we will need to investigate what materials can be used in order to minimize cost of the exoskeleton while maximizing reliability, portability, manufacturability, and comfort. Then, we will need to determine the design specifications, based on the chosen low-cost materials, that can be used to accommodate the majority of users. In relation to the quality of rehabilitation motions, we will need to further research what repetitive upper-limb exercises are effective for stroke rehabilitation. Based on our findings, we will need to determine how to use our sensors and data-processing code to monitor a patient's progress, how to report this progress to the patient or therapist, and how to adjust rehabilitation motions as the patient's mobility improves, specifically how to correlate the force of the actuator to the measurements taken by the sensors.

II. METHODS AND MATERIALS

A. Exoskeleton Design

The exoskeleton design will consist of three DOF: the flexion and extension of the shoulder and the elbow, as well as the abduction and adduction of the shoulder (Figure 4). [26] Actuators and a sensor will be incorporated into the design to initiate and monitor movement of the exoskeleton and upper limb. An inertial measurement unit (IMU) sensor will read in the current position of the arm and provide feedback for the motion of the arm, ensuring safety of the user. The Arduino will read the sensor inputs, throughout the predetermined, cyclic trajectory of the arm, and make sure the exoskeleton is not overextending the arm.

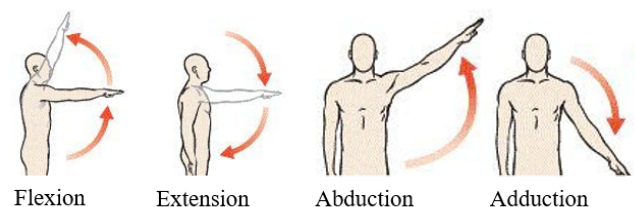

Figure 4: Visual of Motion for Exoskeleton Design [26]

The range of motion will be preset in the Arduino code, and the IMU sensor will ensure the exoskeleton is moving as intended. The range of motion that is desired for each degree of freedom can be seen in Figure 5, where Figure 5.a shows abduction and adduction of the shoulder, Figure 5.b shows the flexion and extension of the shoulder, and Figure 5.c shows flexion and extension of the elbow. The desired range of motion for our final design has been modified from the original goal; the original range of motion goal for the two DOF at the shoulder was 0-90° and the DOF at the elbow was 0-120°. However, due to limitations of the design components selected, these specifications were no longer feasible.

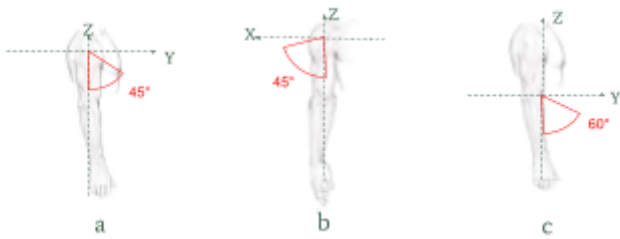

Figure 5: Range of Motion for each Degree of Freedom [10]

Before designing any components of the exoskeleton, the arm, left or right, to which the device was designed needed to be decided. Because left-sided strokes, affecting the right side of the body, are found to be more prevalent, we chose to design the exoskeleton for a patient requiring rehabilitation of the right arm [17]. However, the design of the exoskeleton can be easily reversed for the left arm if needed.

The 3D printed exoskeleton design will consist of two main components: a rigid, 3D printed shoulder housing, and a soft arm/elbow housing. The implementation of a standard brace allows the shoulder housing to be placed in the proper position and allows for the best performance of the exoskeleton. Advantages of custom designing and 3D printing the shoulder component are that weight and cost can be kept low by using cheap and lightweight materials such as ABS, PLA, or PTEG plastics, which will be evaluated and the best candidate selected as part of the design process, and a custom design will allow for precise fitting of specific stepper motor models that will drive the 2 DOF's on the shoulder (flexion/extension and abduction/adduction). The design of the shoulder housing will also be open-source, meaning the CAD model will be freely distributed online in order to increase general accessibility to our designs and potentially ease the difficulty in manufacturing of the design. The shoulder housing will be attached to the user via a soft back brace. The back brace properly aligns the users shoulders and helps ensure proper placement of the shoulder device.

The soft arm and elbow housing will be flexible and adjustable which will allow for people with arms of different sizes to easily use the design without the need for a custom designed part for each individual, and will also increase the comfortability of the design during use. A pneumatic actuator will attach to the elbow component in order to provide flexion/extension of the elbow, and an IMU sensor will be attached in order to track the movement of the arm and provide feedback control for the exoskeleton during use. Our design is outlined visually in the block diagram Figure 6.

The goals of the first prototype design included key aspects of our overall goal. The 3D printed shoulder housing was intended to house stepper motors for one DOF shoulder movement, be printed using low-cost material (PLA Plastic), be an open source design, and attach to the back brace, aligning the shoulder mount and easily attaching to the body. The goal of the design associated with the soft arm and elbow housing for the first prototype was to attach the pneumatic actuator in order to achieve the one DOF of elbow flexion/extension and to ensure the soft, adjustable elbow housing would allow use by users with different sized arms to

wear. These goals for the first prototype were achieved; however, issues in the design arose as we were assembling and testing. Our first prototype did not incorporate the second DOF, adduction and abduction, at the shoulder. Thus our goals for the second prototype design included further development and improvement of the design. Issues from V1 included tolerancing inconsistencies, improper shoulder fit, and issues with the size of the motor housing that we were able to address in V2. V1 only incorporated one DOF at the shoulder so the goal for V2 was to incorporate the second DOF, abduction/adduction of the shoulder, into the shoulder design by editing the fulcrum of the 3D printed motor housing and shoulder design, which we were able to achieve. For our final prototype (V3), our goal was to improve and finalize the design to achieve abduction/adduction at the shoulder, finalize the controls of the pneumatic artificial muscles, create IMU sensor mounting holes, and assemble the overall design.

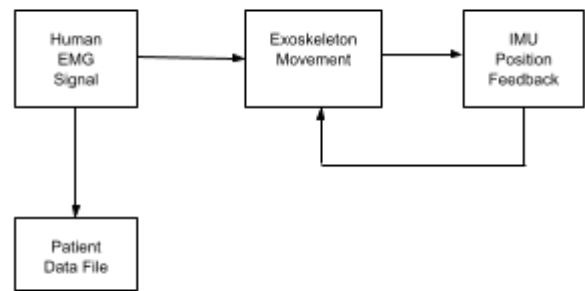

Figure 6: Movement Block Diagram

B. Actuators and Motors

Through the use of stepper motors and pneumatic artificial muscles, we will generate three degrees of freedom. These devices need to be economical and small in order to fulfill the overall design goals of a low-cost and lightweight exoskeleton. They should also be durable to withstand long rehabilitation programs and exhibit slow controlled movement. The ideal range of motion demonstrated by the devices are 0-45° for abduction in the shoulder, 0-45° for flexion in the shoulder, and 0-60° for flexion in the elbow, with a maximum of 90° allowed by the elbow brace. Two stepper motors will allow the movement of abduction/adduction and extension/flexion in the shoulder. A pneumatic actuator will enable the extension/flexion of the elbow.

Stepper motors are DC electric motors that rotate in steps. While smaller stepper motors allow the exoskeleton to be lightweight and portable, they pose the challenge of providing smaller magnitudes of holding torque. The NEMA 17HS15-0404S has a holding torque of 40 Ncm. [30] It has a low-cost of \$13 and is lightweight at 230 g. It also has a relatively small size, as depicted in Figure 7. In testing, the

NEMA 17HS15 motor was found to not work on its own. Recent calculations in V1 show that by itself, this motor can only support a 12 degree maximum movement of the arm. In V2, our solution to this problem was to add a gearbox that will increase holding torque, which in turn will increase the degree of movement and the power of the motor. An EG17-G50 gearbox, as shown in Figure 8, was utilized in V2 and V3 to address this issue. [29] It generates a maximum permissible torque of 10 Nm and moment permissible torque of 20 Nm, which will increase the torque available to drive the load. Additionally, it has a cost of \$52 and weight of 391 g. A second motor with an attached gearbox was ordered for our second degree of freedom. This motor is 17HS15-1584S-MG50 as seen in Figure 9. It has a maximum permissible torque of 10 Nm while being lighter than the motor and gearbox ordered for the first degree of freedom. [28]

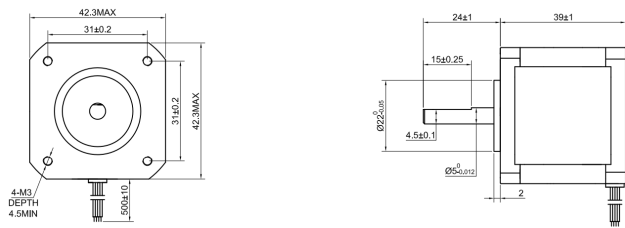

Figure 7: 17HS15-0404S Stepper Motor Dimensions [30]

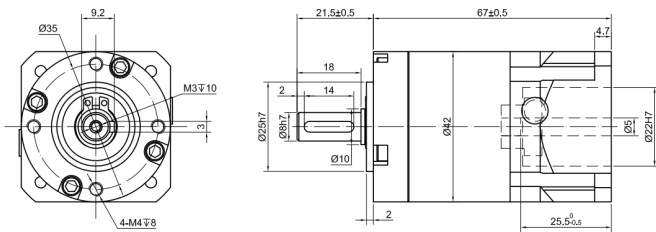

Figure 8: EG Series Planetary Gearbox Gear Ratio 50:1 Dimensions [29]

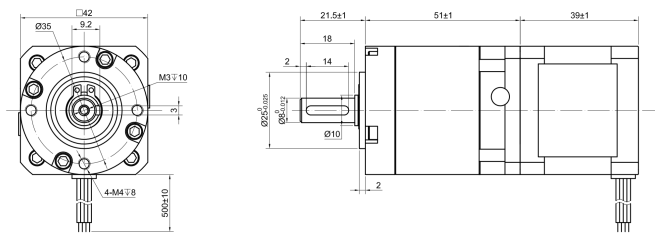

Figure 9: 17HS15-1584S-MG50 Stepper Motor Dimensions [28]

Artificial muscles simulate the shortening and lengthening behavior of natural muscles. Each muscle consists of an inner rubber bladder that is wrapped in a mesh shell. The density of the mesh surrounding the muscle and the direction of stress in the mesh differs with the designs. We will focus on the McKibben muscle that has a braided shell. As the volume of the bladder expands when pressurized, the muscle actuator shortens and produces tension. One difficulty with the McKibben muscle is that it does not completely return to its

initial position when air is released. However, this issue does not pose concern to our exoskeleton goal of providing simple repeated motion.

The first prototype revealed that a single pneumatic actuator did not produce enough force to create the desired range of motion; it produced a maximum angle of about 45°. To combat this issue, the second prototype implements four pneumatic actuators, two shorter actuators with the initial length of 6.5 inches, and two longer actuators with the initial length of 9.5 inches. The mesh diameter and bladder diameter is 3/8 inch and 1/4 inch respectively. They are fixed to the medical arm brace using 3D printed clasps looped through the arm bands, with the brace shown in Figure 10 and the pneumatics set up shown in Figure 11 below. The brace has a cost of \$70.



Figure 10: Side Profile of Arm Brace Figure 11: Pneumatics Set Up

These pneumatic actuators facilitate the flexion and extension of the elbow joint by contracting and lifting the forearm up about 60 degrees from the initial position when supplied with 15 psi from an air pump. The diameter was chosen for the design because it allows the actuator to reach a force necessary to counteract the weight of the forearm, assuming the user is temporarily paralyzed.

The pneumatic motion is controlled by a five way, two-position solenoid valve. The solenoid allows for the flexion/extension of the elbow by allowing flow into the pneumatics for a specified period of time. After the allotted time, the solenoid redirected the flow to allow the pneumatic actuators to release air and lower the forearm. The motion would continue in a cycle until the air compressor was turned off, cutting off the air to the pneumatics.

C. Sensors

The sensor utilized in the exoskeleton is the Adafruit BNO055 IMU sensor. The IMU sensor detects a change in position and angle using accelerometers and gyroscopes for each DOF [3] [19].

Our original plan was to use IMU sensors in combination with EMG sensors, however, due to scheduling constraints we

were unable to incorporate both sensors. EMG sensors are able to detect electrical signals in muscles [22]. A muscle is activated due to concentric or eccentric contractions, meaning that electrical signals will be sent through the muscle in either direction of resulting motion [24]. Therefore, the bicep is activated during the flexion and extension of the elbow, the anterior deltoid is activated during flexion and extension of the shoulder, and the medial deltoid is activated during abduction and adduction of the shoulder [6].



Figure 12: Sensor Placements on (a) IMU sensor on upper humerus [10]

The upper arm and forearm will be treated as a rigid body segment so that the IMU sensor will be able to define the location of the upper arm and forearm in space. The angle of movement will be measured by tracking one input of the sensor. The range of motion will be defined within Arduino and the feedback from the IMU sensors will ensure that the angle is not exceeded. The sensor will be mounted on the outside of the 3D printed brace near the shoulder joint to track the motion. The IMU sensor will help us achieve the goal of repeatable motion via our exoskeleton. This is important to a patient's recovery as the repetitive motion of the stretch is what aids in recovery.

During V1, code was developed and tested to work with IMU, EMG, and our motors. One program uses a set trigger value to read off an EMG sensor, to change an LED status. Another code focused on changing the position of a stepper motor based on a single EMG channel. Finally, segments were combined in V2. Ideally, a patient's EMG signal will trigger the stepper motor function utilizing PID controls through feedback from the IMU.

In V2, we achieved IMU controlled movement for our one degree of freedom arm design. Using an externally mounted IMU sensor on the base of the telescoping arm, we set a target value for the motor to achieve. Using feedback control, the motor was able to loop between its home position and our desired target range of motion value, indefinitely. A problem arose when the IMU readings attempted to transition from 360 degrees to 0 degrees, causing a jitter. This will be addressed in our V3 design. A circuit diagram was also worked on for V2 however needs improvements for V3 due to the implementation of a second degree of freedom.

In V3, we were able to achieve IMU controlled motion for two degrees of motion that were actuated via stepper motors. Similar to V2, an externally mounted IMU sensor was attached near the top of the telescoping arm, and target values for each degree of freedom were set for the motors to achieve. In accordance with the instructions coded using Arduino, the first motor (controlling shoulder flexion/extension) would assist in movement of the arm until the specified range was achieved, then the motor would reverse until the arm had returned to its original position. Next, the second motor (controlling shoulder abduction/adduction) would assist in arm movement until the specified range for that degree of freedom was achieved, and then the motor moved the opposite direction. These movements could then be repeated for as long as desired. The issue with jitter that was present in V2 was resolved by altering the code for reading in the positional data from the IMU. The complete circuit diagram for control of the two stepper motors is shown in Figure 13 below.

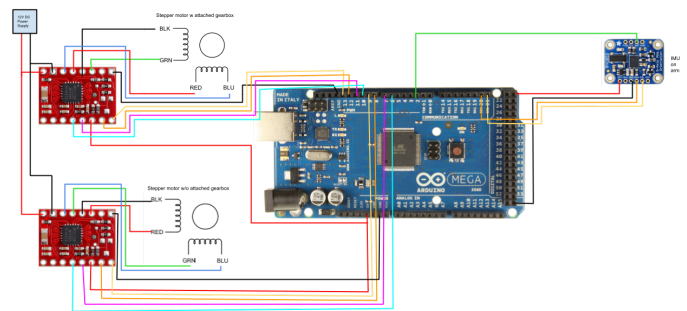

Figure 13: Circuit Diagram of Stepper Motors

D. CAD Design

The CAD prototype designs are displayed in this section. The assembly drawings depict the section that will be located on the shoulder. Through measurements, the human male shoulder to elbow length was assumed to be 10 inches. The measurements of the motor and gear housing was based on the NEMA 17HS15-0404S motor. Using its measurements, a prototype of the 3D printed shoulder piece was created for 2 degrees of freedom. Here the progression of prototypes will be displayed. First will be the progression of 3D printed designs from SolidWorks Software.

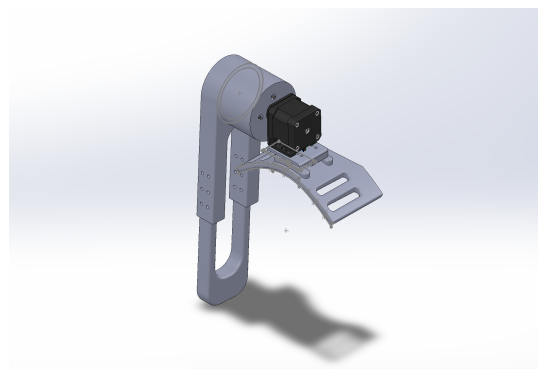

Figure 14: 3D V1 Assembly One DOF

Figure 14 shows the first iterative design. The idea is to have the motor move the arm in one DOF. Problems like motor torque and shoulder comfortability were taken into account. The shoulder housing was inspired from a previous shoulder piece created by Nazirah Farach Rojo and her previous capstone group [23]. In our version, we added structures to hold the motors, as well as structures to hold in place the second DOF shaft using placement of motors, as well as a bearing that will allow the shaft to have sturdy housing as well as free rotation. We also took out their print around the neck. Our plan was to connect the shoulder housing to the body by the back brace, therefore the neck portion of the original design was not needed. We also erased the screw holes and developed our own slots in order to fit the back brace more effectively.



Figure 15: Neck Brace V1 Incorrectly seated on the shoulder due to strap

Upon printing and testing the shoulder piece and motor, several errors were found leading to a strategy for V2's design seen in Figure 15. The bracket fits flat against the shoulder when the back brace is not inserted. When the back brace is threaded through, the thick strap is unable to seat properly above or below the shoulder piece. Additionally, the angle at which the back brace sits twists the piece, as seen in Figure 15. These issues led to design changes in the beginning of V2.

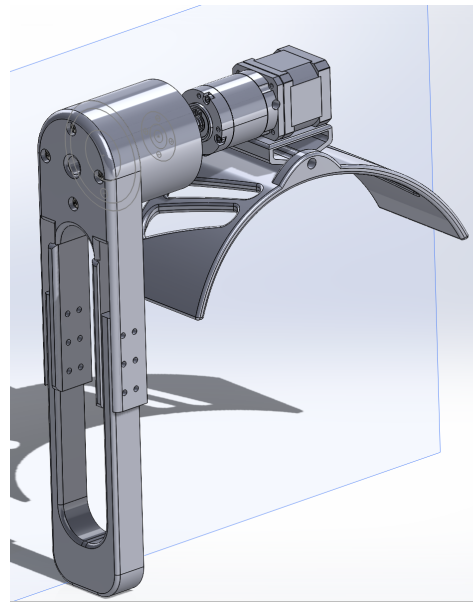

Figure 16: 3D V2 Assembly 1 DOF

Here in V2, the focus was on shoulder comfortability and changing the arm piece to telescoping arms. V2's shoulder piece sits further down the shoulder on both sides. There is also an incorporated plate on the back of the piece to mount components to. V2 also includes a more well rounded housing for the motor as well as a fulcrum piece as the 2 DOF began to take prominence. V2 also includes edits to the motor, as a gearbox was added to help the holding torque. These edits are seen in Figure 16. Screw holes were added to the telescoping arm to give more variance. The fulcrum was placed underneath the telescope for testing of the 2nd DOF. This led to the next design and additions in the 2nd DOF.

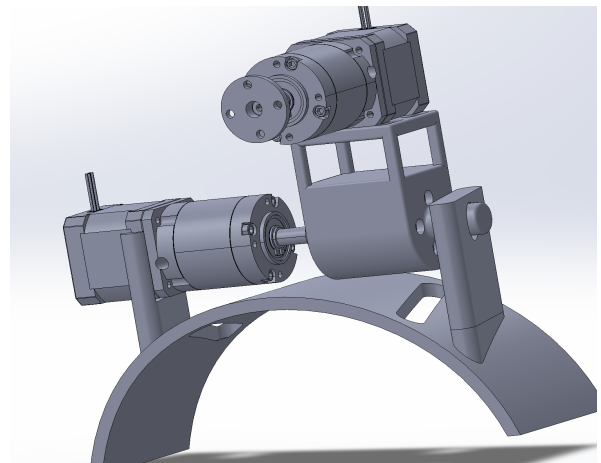

Figure 17: 2 DOF 3D Assembly V2.5 Second DOF

In this time period, V2.5 strategies included the creation of the second DOF shaft. In V2.5, the focus was creating the second degree of freedom while only allowing one telescoping arm and making sure stresses on the shoulder and motor housings were adequate. This fueled the design of new

additions to the shoulder piece, as well as the second degree of freedom shaft. These can be seen in Figure 17. The second degree-of-freedom shaft is located underneath the upper motor, as well as beside the second motor. In this way, the two motors are able to switch which direction the telescoping arm is moving, allowing for two degrees of freedom.

The V2 and V2.5 design corrects previous problems found in V1 including tolerancing issues between parts and screws, the fit of the shoulder brace, and the mounting of the motor. Even though V2 fixed many issues, there were more iterations needed to make the assembly work, including editing the shoulder mount, the telescoping arms, and the second degree of freedom shaft. This led to different iterations in V3.

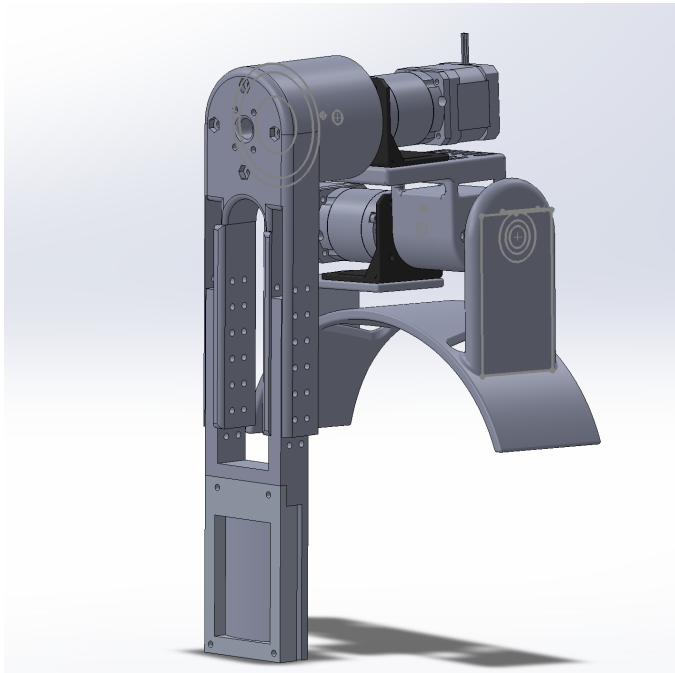

Figure 18: 3D Full Assembly of V3, final submission

Above in Figure 18 is the final iteration of this project, allowing for one telescoping arm to move the shoulder in two degrees of freedom while also allowing for pneumatics to be fit on the arm. Here, edits to the shoulder piece are notable. These edits are adding circular structure to one side, while adding a bearing for smooth rotation. As well as adding better housing for both motors to sit comfortably and tightly on the assembly. The second degree of freedom shaft is edited to be smaller, and for better housing and rotation. The motor torque extender has also been elongated, in order for better position on the shoulder. The outer telescoping arm now has more inserts for screws and screw holes for the IMU placement. More screw holes on the side have been added for more accessibility for different arm lengths. The inner telescoping arm has added a place for the arm to be connected to the pneumatic arm brace, allowing for easier assembly on a patient.

In the next section, drawings of the newest parts added to the assembly will be displayed. These were the main

differences between the previous versions and the latest proposed version. This is the final submitted design.

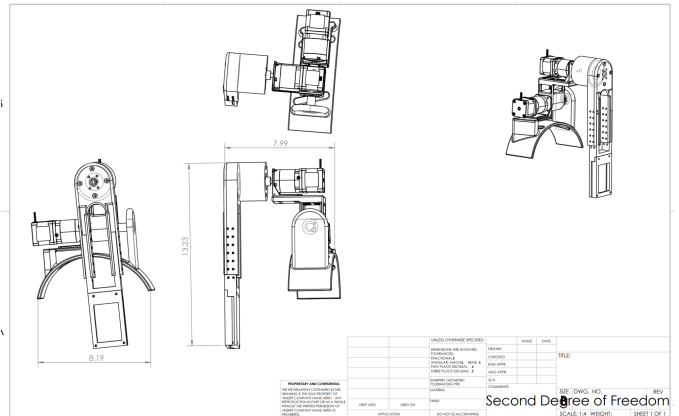

Figure 19: Drawing of Full Assembly in V3

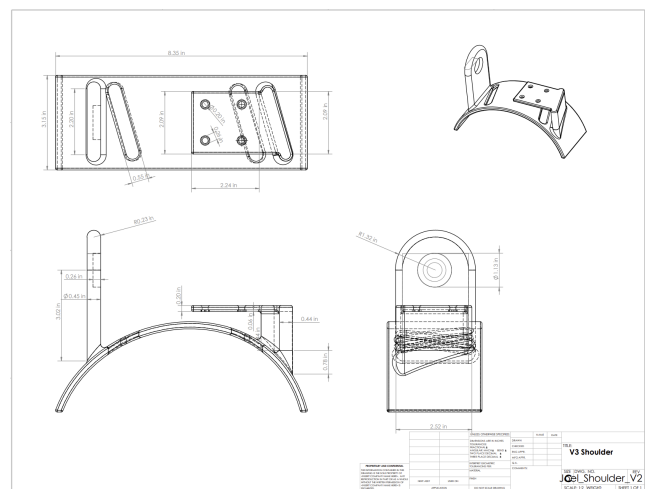

Figure 20: Drawing of Shoulder Housing in V3

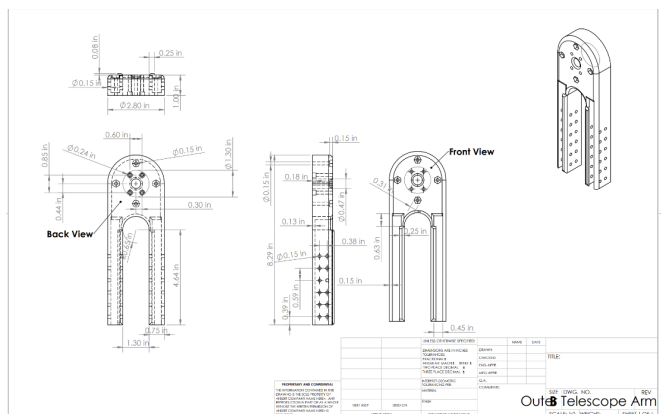

Figure 21: Drawing of Outer Telescope Arm in V3

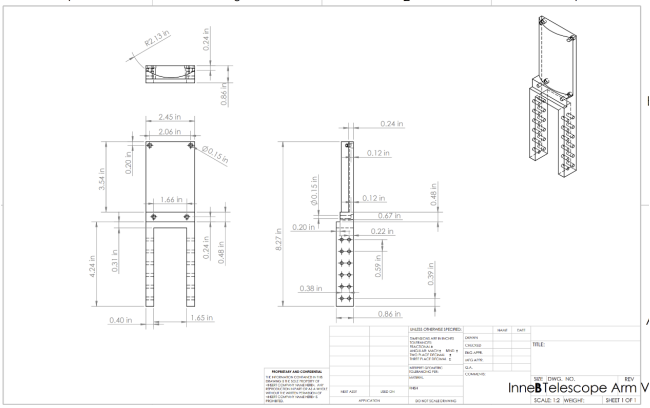

Figure 22: Drawing of Inner Telescope Arm in V3

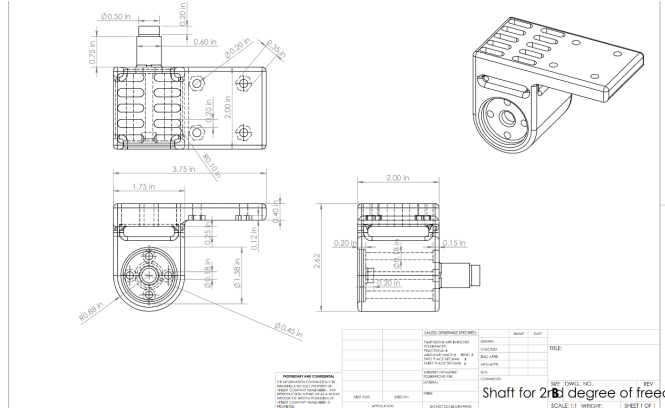

Figure 25: Drawing of Second Degree of Freedom Shaft in V3

Depicted above are both the new shoulder housing, telescoping arms, clamp to pneumatic brace, motor torque extender, as well as the second DOF shaft.

With the shaft, we were able to create a way for both motors to be active, without interfering with one other. This shaft also allows for the newly implemented gearboxes to be added with enough clearance to fit comfortably on the shoulder. With this shaft, the second telescoping arm was not needed, as one arm would suffice for both directions.

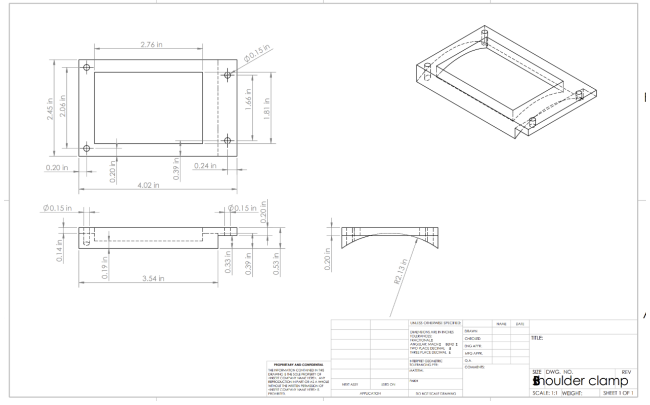

Figure 23: Drawing of Clamp to Pneumatic Arm in V3

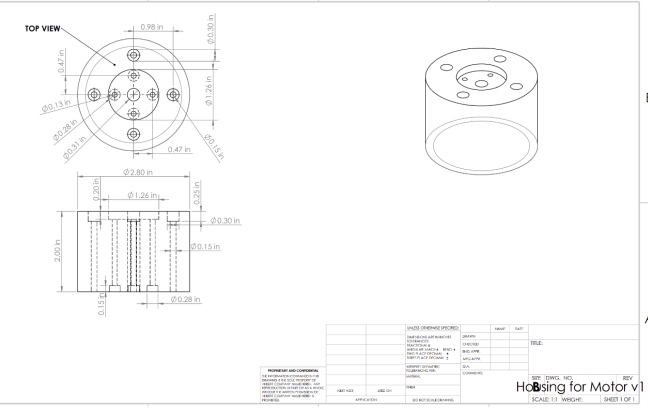

Figure 24: Drawing of Motor Torque Extender in V3

The design was created so the length of the parts on the shoulder down to the telescope arm are 13-14" long (at shortest assembly). The inner telescope arm was modified so that it can connect to the pneumatic elbow brace. This was decided so the design would be easier to put on, and be more cohesive. To avoid creating more weight, smaller 3D printed parts are used, and infill of 10-20% was used depending on the part. The motor housing was made so that a motor mount and four #4-40 screws could be used for the mounting and construction. Four holes were inserted for #6-32 screws, which would be used to connect the motor housing to the outer telescope. The outer telescope is to be paired with the inner telescope, and two #6-32 screws to be put in between to set the length of the total structure of the inner and outer telescopes to be.

Overall, in V3, many of the difficulties of previous versions were solved. In summary, we successfully created a structure that allowed a patient's arm to move in two degrees of freedom at the shoulder. The shoulder housing was able to hold both motors, the second degree-of-freedom shaft, and the telescoping arms, while only weighing about 9-10 lbs. In the testing of the structure, the components moved as intended. There are still some difficulties that must be addressed if this assembly should be commercially sold.

The attachment of the shoulder piece to the body still needs work, as the shoulder piece continuously has to be held, or when the motors move the arm, the shoulder piece begins to move and shift on the shoulder. A padding also needs to be decided upon in order for the shoulder mount to fit comfortably. This also goes along with finding a way to comfortably connect it to the user's body. When connected, a large gap was found between the user's arm and the pneumatic

piece due to the placement of the 3D assembly. The vibrations of the motor continue to loosen certain screws, as well as cause some slipping when the arm is being moved. Another issue is sometimes the shaft for the second degree of freedom comes too close to the user's head, which can be a safety concern for multiple reasons. This needs to be fixed either with a covering over the motors, or a smaller and more efficient shaft. In V3, there are many ways in which we can improve the efficiency and safety of our prototype in order for it to be commercially sold or available. But, V3 is successful in that it is proof our design is viable, and is worthy to be continuously worked on.

E. Evaluation

We conducted a series of experiments to determine whether our exoskeleton design met specifications, specifically to verify the range of motion generated by each degree of freedom. We also conducted experiments to make sure our combination of motor and gearbox was powerful enough to lift the arm to our desired degree, as well as experiments to verify that our pneumatic muscle is powerful enough to contract the arm. We also made sure the 3D printed designs for each degree of freedom worked together correctly with wiring, thus allowing the IMU sensor to work properly. Achieving these specifications ensures our design can execute the necessary repetitive, upper-limb motions for effective stroke rehabilitation therapy. In future evaluation, smoothness of movement, and easiness to assemble and use will be explored in order for this product to be commercially ready.

1) Range of Motion

In order to achieve the range of motion design specifications, we used the actuators and motors previously specified. The exoskeleton design will ideally produce three degrees of freedom: 0-60° of flexion and extension for the elbow, 0-45° of flexion and extension for shoulder, and 0-45° of abduction and adduction for the shoulder. Using healthy individuals with different anthropometric parameters as subjects, we measured their range of motion with the exoskeleton's assistance, carrying out each degree of freedom individually using the IMU. We found that, with minimal to no assistance from the user, the exoskeleton achieved 0-60° of flexion and extension for the elbow, 0-45° of flexion and extension for shoulder, and 0-45° of abduction and adduction for the shoulder at a maximum. We determined that physical aspects of our design were the primary constraints to all three degrees of freedom, with the torque output of the motors also being a limiting factor for shoulder motion.

2) Force to Lift the Arm

We have gathered data from two subjects on the amount of force required to lift their arms. The purpose of this was to have baseline measurements that can be used to approximate the required torque from the motors and the required force from the pneumatic artificial muscles. The force

measurements were taken using a spring balance attached to an arm strap. The subject would relax their arm as we raised the spring balance slowly. The force reported in Table I was after the subject's arm reached the maximum range of motion we desired by use of the exoskeleton and while the subject's arm was at rest. The shoulder measurements were taken with the arm strap at the bottom of the shoulder and the elbow measurement was taken with the arm strap at the wrist. To test this further, the exoskeleton design was utilized on a healthy individual to initiate flexion of the shoulder joint using only power from the motor.

	Force to Lift Arm (lbs)	
Type of Motion	Subject 1	Subject 2
Shoulder Flexion	10	9
Shoulder Abduction	7.8	8.9
Elbow Flexion	3.5	3

Table I: Force to Lift the Arms of Two Different Subjects

3) Pneumatic Actuator Testing

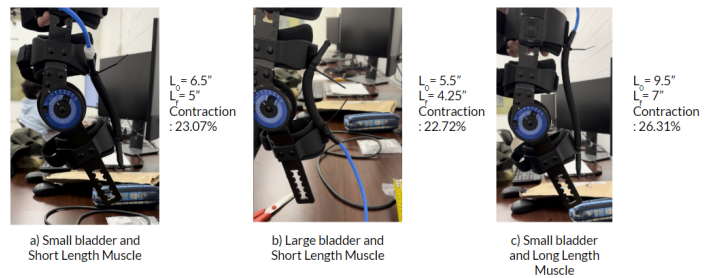

Figure 26: pneumatic actuator experimentation with varied bladder sizes and lengths, tested at 27.5 kPa (4 psi)

Experimentation of pneumatic actuators included variation of the mesh, as well as variation of the inner bladder diameter and its elasticity. The largest contraction occurred with a small bladder and longer length, so that the entire actuator was connected to the lower elbow band and the upper shoulder band. The distance contracted was 2.5 inches, with a contraction of overall length equal to 26.31%. Based on the results of these tests, the pneumatic design of the elbow will incorporate multiple actuators acting at the same time in order to increase overall contraction distance.

4) IMU Sensor Placement Testing

Experimentation to confirm IMU placement consisted of varying the placement of the sensor then moving the arm in the desired motion. The sensor was attached to the arm via tape so that measurements would not deviate based on an individual holding it. It was concluded that the plotted IMU

data appeared best when one channel was isolated and the sensor was positioned per Figure 12.

5) Low-Cost Analysis

To confirm the designed exoskeleton is low-cost, the following estimated Table II was put together. The final estimated cost of the exoskeleton came out to \$518.03. These values however reflect current market prices. It is also important to note these weren't the total accrued costs of our experimentation as many things from the list were already available in our lab such as solder, the soldering iron, and various tools used in assembly. This cost table does not account for shipping or tax.

Name and Link	Cost (per unit)	Quantity	Total
Back brace	\$18.97	1	\$18.97
Elbow brace	\$69.97	1	\$69.97
Portable Air Compressor	\$50.99	1	\$50.99
2 Position 5 Way Solenoid Valve	\$16.99	1	\$16.99
Stepper Motor Driver	\$12.95	2	\$25.90
Elegoo Mega	\$19.99	1	\$19.99
Adafruit BNO055	\$34.99	1	\$34.99
Ball Bearing	\$6.75	1	\$6.75
EG Series Planetary Gearbox 50:1	\$54.51	1	\$54.51
Nema 17 Stepper Motor with MG Series Planetary Gearbox	\$37.16	1	\$37.16
Adjustable DC Power Supply	\$59.99	1	\$59.99
SPCS 8mm Flange Coupling	\$13.99	1	\$13.99
Super-Stretchable Natural Rubber Rod	\$1.64	10	\$16.40
Expandable Sleeving	\$3.69	1	\$3.69
Heat-Shrink End Cap	\$1.70	10	\$17.00
Nema 17 Bipolar	\$8.97	1	\$8.97
NEMA 17 Stepper motor Mount	\$4.95	2	\$9.90
Stranded Copper Wires	\$9.99	1	\$9.99
#6-32 Screws	\$11.40	1	\$11.40
#6-32 Nuts	\$2.78	1	\$2.78
#4-40 Screws	\$9.99	1	\$9.99
#4-40 Nuts	\$1.24	4	\$4.96
Polyurethane Rubber Tubing	\$12.75	1	\$12.75
Estimated Project Total			\$518.03

Table II: Estimated Exoskeleton Costs

F. Future Work

1) EMG Sensor Implementation

Further work on the 3D printed exoskeleton sensor design includes integrating EMG sensors along the activated arm muscles in order to initiate motion. The current design begins motion when the code is run for the flexion/extension and abduction/adduction of the shoulder, and when the air compressor is turned on for the flexion/extension of the elbow. The EMG would allow for the patient to gain a sense of autonomy in controlling their arm. Furthermore, the user would be able to trigger the device to move in only one direction at a time based on which EMG receives the signal. This will ensure patient safety while operating.

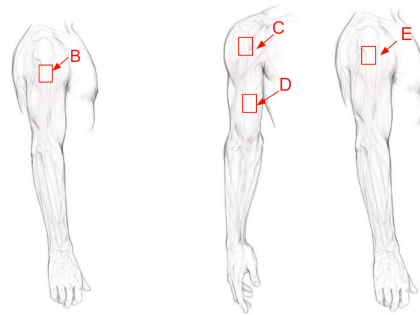

Figure 27: Sensor Placements (b) IMU sensor on upper humerus, (c) EMG sensor on anterior deltoid, (d) EMG sensor on bicep, (e) EMG sensor on medial deltoid [10]

There could be three EMG sensors placed on the active muscles, one for each DOF to gauge the recovery of muscles and potentially initiate exoskeleton motion: one on the bicep, the anterior deltoid, and the medial deltoid as shown in Figure 27. Because strokes may result in muscle weakness or paralysis, the EMG sensor would be used to detect any electrical signals through the muscles for the prescribed motions. The sensor would send the signals to the Arduino and would be recorded to track muscle recovery. This use of the EMG sensor allows the goal of tracking a patient's recovery. This data could be stored and made available to a patient or their healthcare team to monitor their progress and determine if the current course of action is working as intended.

2) Servo Motors Instead of Stepper Motors

The decision to use stepper motors instead of servo motors was made because they are cheaper and have higher holding torques than servo motors; however, throughout the design process, gearboxes were used to enhance the motors ability to facilitate arm motion. Servo motors could be implemented instead because they reduce the weight of the overall exoskeleton, which is an important factor in the design because the weight rests on the patient's shoulder. Furthermore, using servo motors would allow the motors to be mounted closer to the shoulder, and would not risk interacting with the patient's head upon motion of the shoulder. The required torque for the entire arm would decrease.

3) Overall Design Improvements

The 3D design could be modified so that the shoulder mount has less strain on the body and may be more comfortable for the user. It could also be adjusted to have a more balanced foundation, so that when the exoskeleton begins the motion, it remains secured to the shoulder. Further iterations of the shoulder flexion mount could address the current design which rotates towards the patient's head. Due to the use of two motors as well as a solenoid, the circuit and subsequent wiring was highly complex for a person outside of the design team to understand. Sometimes the wires would disengage from the breadboard, resulting in a malfunction of the exoskeleton. The future designs could incorporate soldered wires so that their connection is not an issue for the user. Lastly, the general assembly of each component could be adapted to look more aesthetically pleasing and overall performance could be enhanced to provide a more controlled, smoother motion using the motors.

III. DISCUSSION AND CONCLUSION

A. Discussion

Some concerns with the current design that will need to be investigated further include the angle reading of the IMU sensor. Due to its placement on the exterior of the upper telescoping arm, the angle that is read through the IMU varies from the true angle the user's arm travels. When the IMU sensor rotated 20 degrees, the patient arm rotated 45 degrees. Potential solutions to this design issue include placing the IMU on a different location of the arm, or editing the 3D printed design so that the point of rotation of the motors is closer to the shoulder joint of the patient.

Other concerns that appeared based on the first prototype design, such as the amount of torque needed have been addressed. The main concerns of our second prototype are the stresses on the new shoulder mount and second DOF shaft. After printing, testing will be done with the new 3D printed models, and with subjects to make sure the torques are large enough, and the arm can indeed move in 3 DOF. For the pneumatics, other actuators are being looked at to test for more movement and larger range of motion. We want to make sure that we have looked at every possibility we can to make large movements for the patient. With this, we also want to make sure that the design is comfortable and easy to work with for the consumer/patient. Easiness of building, as well as execution of the exoskeleton will be tested and explored.

B. Conclusion

In this paper we overview the serious issues that stroke poses, how the resulting damage can hinder a patient's physical abilities, and outline our goal to design and create a 3D printed robotic upper-limb exoskeleton that will be able to assist in stroke rehabilitation exercises. Our proposed design allows for three degrees of freedom for upper-limb motion, and the 3D printed design aims to reduce costs compared to similar products in order to provide a more accessible

alternative for consumers. Movement was produced for all three DOF, although the range of motion of the exoskeleton is below the initially desired values.

The pneumatic actuator design for the flexion/extension of the elbow was tested through multiple configurations, and it was found that when pneumatics were used in parallel, it increased the force of the actuator, and when they were used in series, it increased the contractile length. Therefore, pneumatics were used both parallel and series for the elbow to provide the best range of motion.

ACKNOWLEDGMENT

This research was supported by Dr. Sarah Sun, Sarah Hemler, and the University of Virginia. We thank our colleagues from the University of Virginia who provided insight and expertise that greatly assisted the research, although they may not agree with all of the interpretations and conclusions of this paper.

REFERENCES

- [1] A. Grandi, A. Karthikeyan, E. Junior, and M. Rodriguez, "Low-cost 3D printed exoskeleton for post-stroke hand rehabilitation," *Computer-Aided Design and Applications*, vol. 19, no. 6, pp. 1207–1215, 2022.
- [2] A. González-Mendoza, I. Quiñones-Urióstegui, S. Salazar-Cruz, A.-I. Perez-Sanpablo, R. López-Gutiérrez, and R. Lozano, "Design and Implementation of a Rehabilitation Upper-limb Exoskeleton Robot Controlled by Cognitive and Physical Interfaces," *J Bionic Eng*, vol. 19, no.5, pp. 1374–1391, Sep. 2022, doi: 10.1007/s42235-022-00214-z.
- [3] A. Sanjeev, "How to Interface Arduino and the MPU 6050 sensor: Arduino," *Maker Pro*, 21-Mar-2018. <https://maker.pro/arduino/tutorial/how-to-interface-arduino-and-the-mpu-6050-sensor>. (accessed Nov. 11, 2022).
- [4] A. Zeiaee, R. S. Zarrin, A. Eib, R. Langari and R. Tafreshi, "CLEVERarm: A Lightweight and Compact Exoskeleton for Upper-Limb Rehabilitation," in *IEEE Robotics and Automation Letters*, vol. 7, no. 2, pp. 1880-1887, April 2022, doi: 10.1109/LRA.2021.3138326.
- [5] A. Zeiaee, R. Soltani-Zarrin, R. Langari and R. Tafreshi, "Design and kinematic analysis of a novel upper limb exoskeleton for rehabilitation of stroke patients," *2017 International Conference on Rehabilitation Robotics (ICORR)*, 2017, pp. 759-764, doi: 10.1109/ICORR.2017.8009339.
- [6] American Council on Exercise, "Muscles That Move the Arm," *ACE*, 23-Feb-2017. <https://www.acefitness.org/fitness-certifications/ace-answers/exam-preparation-blog/3535/muscles-that-move-the-arm/>. (accessed Nov. 11, 2022).
- [7] American Heart Association Editorial Staff, "Spasticity," *www.stroke.org*, 09-Mar-2022. <https://www.stroke.org/en/about-stroke/effects-of-stroke/physical-effects-of-stroke/physical-impact/spasticity#:~:text=Spasticity%20is%20a%20common%20post,soft%20tissue%20can%20become%20tight>. (accessed Nov. 11, 2022).
- [8] American Stroke Association "About Stroke" <https://www.stroke.org/en/about-stroke> (accessed Nov. 11, 2022).
- [9] B. W. K. Ang and C. -H. Yeow, "Design and Characterization of a 3D Printed Soft Robotic Wrist Sleeve with 2 DoF for Stroke Rehabilitation," *2019 2nd IEEE International Conference on Soft*

Robotics (RoboSoft), 2019, pp. 577-582, doi: 10.1109/ROBOSOFT.2019.8722771.

- [10] CGCookie, "Arm Anatomy Resource," CG Cookie, <https://cgcookie.com/downloads/arm-anatomy-resource>.
- [11] C. W. Tsao *et al.*, "Heart Disease and Stroke Statistics—2022 Update: A Report From the American Heart Association," *Circulation*, vol. 145, no. 8, pp. e153–e639, Feb. 2022, doi: 10.1161/CIR.0000000000001052.
- [12] Chris, "Stroke Rehab: Slow Stretching – The Practical Occupational Therapist." <https://thepacticaloccupationaltherapist.wordpress.com/2017/09/24/stroke-rehab-slow-stretching/> (accessed Nov. 11, 2022).
- [13] E. Korzeniewska, A. Krawczyk, J. Mróz, E. Wyszynska, and R. Zawislak, "Applications of Smart Textiles in Post-Stroke Rehabilitation," *Sensors (Basel)*, vol. 20, no. 8, p. 2370, Apr. 2020, doi: 10.3390/s20082370.
- [14] Goural, "Shoulder-arm-hand support and positioning orthosis after stroke," https://www.goural.fr/en/shoulderarmhand-support-and-positioning-orthosis-after-stroke-xml-1773_585_1954-11130.html
- [15] H. Thieme, N. Morkisch, J. Mehrholz, M. Pohl, J. Behrens, B. Borgetto, and C. Dohle, "Mirror therapy for improving motor function after stroke," *Cochrane Database of Systematic Reviews*, vol. 2018, no. 7, Jul. 2018.
- [16] Healthwise Staff, "Stroke MRI," *Cigna*, 17-Jun-2021. <https://www.cigna.com/knowledge-center/hw/stroke-mri-zm5002> [Accessed: 10-Nov-2022].
- [17] Hedna VS, Bodhit AN, Ansari S, Falchook AD, Stead L, Heilman KM, et al. "Hemispheric differences in ischemic stroke: is left-hemisphere stroke more common?" *J Clin Neurol*. 2013; 9:97–102. doi: 10.3988/jcn.2013.9.2.97
- [18] J. Rodil. OTR/L MS, "Fine Motor Skills Defined by an Occupational Therapist," *NAPA*, May 18, 2020. <https://napacenter.org/fine-motor-skills/> (accessed Nov. 11, 2022).
- [19] K. Townsend, "Adafruit BNO055 Absolute Orientation Sensor," Adafruit, April 22, 2015. <https://learn.adafruit.com/adafruit-bno055-absolute-orientation-sensor>
- [20] L. Oujamaa, I. Relave, J. Froger, D. Mottet, and J.-Y. Pelissier, "Rehabilitation of arm function after stroke. literature review," *Annals of Physical and Rehabilitation Medicine*, vol. 52, no. 3, pp. 269–293, 2009.
- [21] M. Gandolla *et al.*, "An assistive upper-limb exoskeleton controlled by multi-modal interfaces for severely impaired patients: development and experimental assessment," *Robotics and Autonomous Systems*, vol. 143, p. 103822, Sep. 2021, doi: 10.1016/j.robot.2021.103822.
- [22] N. Agnihotri, "Designing an Arduino-based EMG Monitor," *Engineers Garage*. <https://www.engineersgarage.com/arduino-based-emg-monitor-ad8226/>. (accessed Nov. 11, 2022).
- [23] Farach Rojo, N. "Upper Limb Exoskeleton for Shoulder Joint Control; A Double-Edged Sword: How the Prosthetics Industry Perpetuates Mental Health Disorders," Charlottesville, VA: University of Virginia, School of Engineering and Applied Science, BS (Bachelor of Science), 2022. doi: 10.18130/eehb-xq93
- [24] N. Major, M. Anderson, C. Helms, P. Kaplan, and R. Dussault, "Tendons and Muscles," *Musculoskeletal MRI*, no. Third Edition, pp. 53–84, 2020.
- [25] NINDS, "Post-Stroke Rehabilitation Fact Sheet," *National Institute of Neurological Disorders and Stroke*, Apr-2020. <https://www.ninds.nih.gov/post-stroke-rehabilitation-fact-sheet> (accessed Nov. 11, 2022).
- [26] PassTheOT, "Scapula and Shoulder Movements," Pass The OT, <https://passtheot.com/scapula-and-shoulder-movements/>.
- [27] Physiopedia, "NIH Stroke Scale," *Physiopedia*. https://www.physio-pedia.com/NIH_Stroke_Scale. (accessed Nov. 11, 2022).
- [28] StepperOnline, "Nema 17 Stepper Motor L=40mm gear ratio 50:1 MG series planetary gearbox," StepperOnline, <https://www.omc-stepperonline.com/nema-17-stepper-motor-l-40mm-gear-ratio-50-1-mg-series-planetary-gearbox-17hs15-1584s-mg50>
- [29] StepperOnline, "EG series planetary gearbox gear ratio 50:1 backlash 20 arc-min for Nema 17 Stepper Motor," StepperOnline, <https://www.omc-stepperonline.com/eg-series-planetary-gearbox-gear-ratio-50-1-backlash-20-arc-min-for-nema-17-stepper-motor-eg17-g50>
- [30] StepperOnline, "NEMA 17 bipolar 1.8deg 40NCM (56.6oz.in) 0.4a 42x42x39mm 4 wires," StepperOnline, <https://www.omc-stepperonline.com/nema-17-bipolar-1-8deg-40ncm-56-6oz-in-0-4a-12v-42x42x39mm-4-wires-17hs15-0404s>
- [31] "Stroke MRI | Cigna." <https://www.cigna.com/knowledge-center/hw/stroke-mri-zm5002> (accessed Nov. 11, 2022).
- [32] Y. Ganesan, S. Gobee, and V. Durairajah, "Development of an Upper Limb Exoskeleton for Rehabilitation with Feedback from EMG and IMU Sensor," *Procedia Computer Science*, vol. 76, pp. 53–59, Jan. 2015, doi: 10.1016/j.procs.2015.12.275.
- [33] "(PDF) A Survey on applications of Pneumatic Artificial Muscles." https://www.researchgate.net/publication/259310538_A_Survey_on_applications_of_Pneumatic_Artificial_Muscles (accessed Nov. 11, 2022)