

Capstone: Autonomous & Water-Free Solar Panel Cleaner

A Technical Report submitted to the Department of Mechanical Engineering

Presented to the Faculty of the School of Engineering and Applied Science
University of Virginia • Charlottesville, Virginia

In Partial Fulfillment of the Requirements for the Degree
Bachelor of Science, School of Engineering

Brandon Bonner

Spring, 2022

Technical Project Team Members

Joshua Belisle

Nicholas Langer

On my honor as a University Student, I have neither given nor received unauthorized aid on this assignment as defined by the Honor Guidelines for Thesis-Related Assignments

Dr. Michael Momot, Department of Mechanical Engineering

Executive Summary

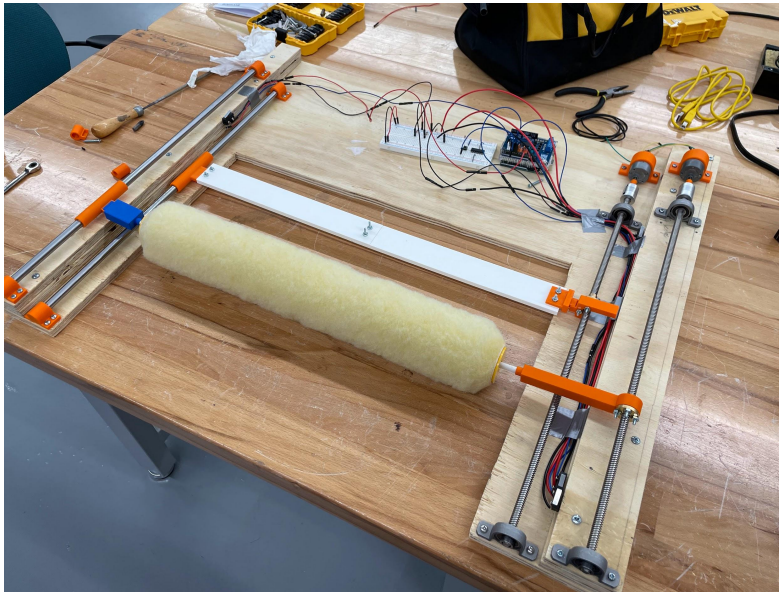
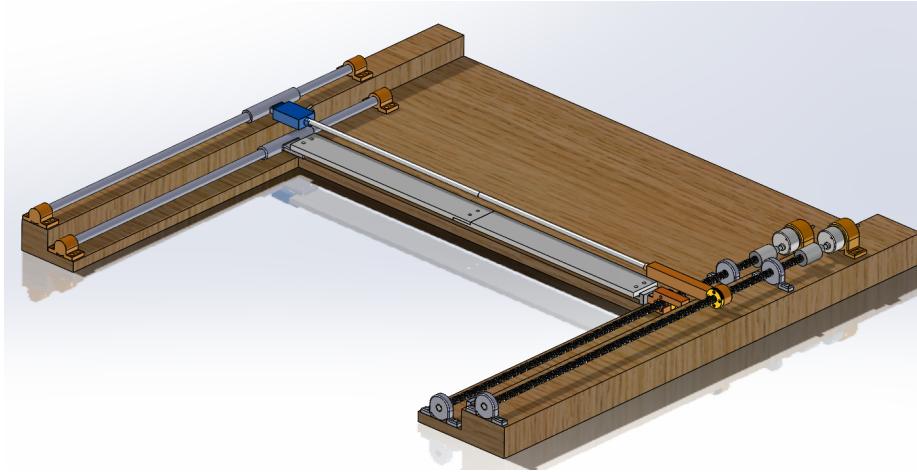

Figure 1. Full CAD Design and Physical Model of our proposed solution.

This report will outline the problem statement, background research, design process, prototype, and testing performed by our capstone group over the course of the 2022-2023 academic year. It will also highlight the needed future work that could be explored to make our autonomous and water-free solar panel cleaner a viable solution for solving solar panel soiling. Above is the final prototype of our proposed autonomous solar panel cleaning system, utilizing a charged plate and brush system to effectively clean all types of debris in a new, water-free way.

Note: Our team had 4 members during the Fall 2022 semester. The work done during that semester was continued by the three members listed on the title page. However, work done by

the 4th member (Kyleigh Talomie) is included in this report and will be treated as if she continued working on the project. Kyleigh consented to all of her work being used in this report.

Introduction

The objective of this capstone project is to design an automated cleaning system for solar panels. Solar panels can often soil, meaning they have foreign objects such as dust, dirt, and leaves on the solar panel surface. Soiling of solar panels can lead to drastic decreases in solar panel efficiency and power output production. This drawback is solved by solar panel cleaning, which keeps solar panels operating at peak efficiency for the most amount of time possible. The goals of our capstone project are to create an autonomous solar panel system that requires minimal human interaction, eliminates water consumption, and increases safety surrounding solar panel cleaning.

Background

Research

Reductions in efficiency due to the accumulation of dust on the surface of a solar array are called soiling losses. These losses are much more significant in areas like North Africa and the Middle East, where the environment is conducive to dust accumulation. One study from 2001 in Iran found that “the power output of a [photovoltaic] system decreased by more than 60% because of air pollution that covered the surface of the PV panel which obstructed the sunlight” (Asl-Soleimani et. al as cited in Maghami et. al, 2016, p. 1312). In the United States, soiling losses can lead to a 7% reduction in efficiency (Hicks, 2021). To limit these large reductions in efficiency, solar panels must be cleaned. Cleaning mechanisms ranging from electrically charged plates to soap and water systems will be considered along with their motion and/or distribution to the rest of the solar panel array.

There are many commonly-used solar panel cleaning techniques, however, all current options have substantial downsides. Professional cleaning services are usually effective, but extremely expensive. Therefore, it is not typically financially sustainable to frequently hire professional cleaners. Another method is the use of sponges with cleaning solutions or soaps. The use of sponges introduces the potential for debris accumulation and panel scratching, cleaning solutions can be corrosive and harmful to the environment, and soaps can leave a residue that causes more dust and dirt to attach to panels (*How To Clean Solar Panels To Reduce Energy Costs - Bob Vila*, n.d.). The use of hose water to clean panels can be ineffective if proper water softening, deionization/distillation, and decalcification does not occur. In addition, an exorbitant amount of water must be used to ensure thorough cleaning (Pickerel, 2020). Lastly, traditional methods of scrubbing the panel using household cleaning brushes can most notably

result in panel scratching, which should always be avoided to prevent energy production capability reduction.

To help solve the water usage problem for solar panel cleaning, MIT researchers have recently developed a system for removing dust particles from solar panels using electrical charge. The system consists of two elements, a charged aluminum plate and an aluminum-doped zinc oxide (AZO) coated glass. The AZO coating is applied to the glass using atomic layer deposition and becomes the bottom electrode. The steel plate is charged and passed over the solar panel, becoming the top electrode. The opposite charges impart an electrical charge on the dust particles, removing them from the solar panel surface. The essential aspect of this new technology is that it doesn't require water. It is estimated that 10 billion gallons of water is used annually worldwide with the current methods of cleaning solar panels. The charged plate solution demonstrates promise in solving the water issue in solar collection (Panat & Varanasi, 2022).

Constraints

In order to begin thinking about possible solutions, we created a list of constraints our system needed to follow. These constraints helped create a deliverable that follows all the specifications while also providing us with a framework for the design. The constraints our group emphasized for the design were:

1. A system that is safe and can be easily installed to already present solar panel systems
2. A system that is able to adapt to all weather conditions
3. A system that can clean multiple solar panels in one cleaning cycle
4. A system that can be used for many cleaning cycles
5. A system that does not harm the solar panel
6. A system that is low cost to produce
7. A system that could be manufactured and recreated repeatedly
8. A system that could be sustainable by minimizing water consumption and minimize waste

These constraints were used in the screening and scoring process to assess the feasibility of the ideas generated.

Specifications

Given this problem statement, there are various constraints and specifications that must be met in order to develop a successful system that goes beyond the constraints we placed on ourselves. The list of specifications is as follows:

1. The system must clean the entire solar panel
2. The system must be able to rest outside of the occlusion zone when not in use
3. The system must be cheap to produce and affordable to purchase

4. The system must be able to operate on angles ranging from 0° to 35° so it can be used on solar panels in various settings
5. The system must account and function under all weather conditions
6. The system must secure safely to the solar panels and be safe
7. The system must be reusable and a better alternative than currently available

A successful system will be able to account for all constraints and specifications as well as be designed for sustainable use and provide a much improved way to clean solar panels.

Design Process

Concept Selection

In order to reach the first iteration of our design, an extensive screening and scoring process was performed. The screening and scoring process is a method in which groups create many designs and then combine, iterate, and think through all aspects of the design in order to develop the best possible design.

The screening and scoring process was started by having all group members think of and sketch five individual ideas. As can be seen in Figure 2, these designs are simple concepts on how to clean solar panels that attempt to fulfill some of the constraints and specifications.

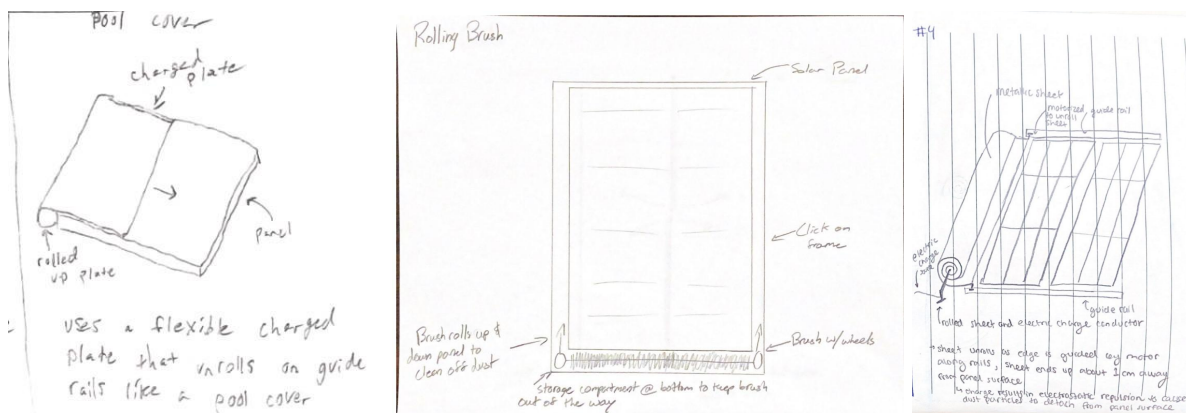

Figure 2. A Sample of the Initial Ideas Generated

After compiling all the ideas, it was discovered that some of the ideas generated individually were identical or extremely similar to other member's ideas. These ideas were combined to provide a total of 13 original and unique ways to clean a solar panel. These 13 ideas were then moved forward to the screening process.

In order to screen all the ideas, the group created various categories that the ideas would be rated upon. These categories stem from the constraints and specifications as well as expand upon the feasibility and manufacturability of the idea. Then, each idea was rated on a scale of -1, 0 or 1; -1 meaning the idea will most likely fail, 0 meaning it is unknown or unclear if it will succeed or fail, and 1 meaning it will most likely succeed. Table I (below) is the average of each group member's rating for each idea for each category.

Criteria	Rolling Charged Cylinder	Moving Robot	Pool Cover with Charged Plate	Charged Plate with Sprinklers	Sprinklers and Wiper	Moving/Rolling Brush	Fans	Water Sprinkler	2 Hinged Brush	Screen Protector	Wiper Blades	"Squeegee" System	Water Pipe on Guidetrails
Hide Ability													
Out of 45 deg zone	0.25	-0.75	1	0.5	0.25	0.25	0.75	1	0.25	0	0	0	0.5
Weather Adaptable													
Sun	0.75	0	1	1	0.75	0.75	1	0.75	0.75	0.25	0.5	0.5	0.5
Water	-0.25	-0.25	0	0.5	1	0.75	0	0.75	1	0.75	1	0.75	1
Snow	-0.75	-1	-0.75	-0.75	-0.75	0	-0.5	-0.25	-0.5	-0.5	0.75	-0.25	-0.5
Wind	0.5	-0.25	0.75	0.75	0.5	0.75	0.25	-0.25	0.75	0.75	0.25	0.5	0.25
Cost													
Cheap	-0.25	-0.75	-0.25	-0.25	0.75	0.5	0	0.5	-0.25	0.5	0.25	0	0
Operation													
angled from 0-35 deg	1	-1	1	1	1	1	0.75	0.5	0.5	1	1	0.75	0.5
Installation													
Easy	0	0.5	0.25	0	0.75	0.5	0.5	0.5	0.25	0.75	0.75	-0.25	0
Repeatable	0.25	1	0.5	0.75	0.75	0.75	0.5	0.5	0.5	0	0.5	0.5	0.5
Safe	0.5	-0.25	0.5	0.5	0.75	0.75	0.5	0.5	0.75	0.75	0.75	0.75	0.75
Mechanical Simplicity													
Number of components	0	-0.75	-0.5	-1	0.5	0.75	0.25	0.75	-0.5	1	0.25	-0.5	0
Moving parts	-0.5	-0.5	-0.75	-0.5	0	0	-0.25	0.25	-0.75	1	-0.25	-0.75	-0.5
Coverage Area													
Cleans multiple at once	0.25	0.5	0	0.5	0	0.25	0.25	0.25	-0.25	-0.25	0	0	0.25
Cleans whole panel	1	0.75	1	1	0.25	0.75	0	0.25	0.25	0.5	-0.5	0.25	0.25
Longevity													
Cleaner itself	0.25	0	0	0	0.75	0.75	-0.25	0.75	0	-0.75	0.5	0	0.25
Doesn't damage panel	0.75	0	0.75	1	0.5	0.75	0.75	0.75	-0.5	0.25	-0.25	0	0.5
Pluses	10	4	9	10	13	13	10	14	9	11	11	7	11
Neutrals	2	3	3	2	2	2	3	0	1	2	2	5	3
Minuses	4	9	4	4	1	1	3	2	6	3	3	4	2
Total	3.75	-2.75	4.5	5	7.75	7.75	4.5	7.75	2.25	6	5.5	2.25	4.25
Rank	10	13	7	6	3	1	8	2	11	4	5	12	9
Selections			x	x	x	x		x					

Table I. The Average of Each of the 4 Team Members Rating During Scoring. This was conducted in the Fall 2022 semester, when our team had 4 members.

As can be seen, the 5 best rated ideas from the screening phase were selected to move to the scoring phase of the ideation process. The scoring process worked by assigning percent values to the categories of criteria, the higher the percentage signifying the more important the criteria. This allows the ideas that are far superior in the most important categories to score higher than the ideas that will be mediocre in all categories. One of the points of emphasis for this capstone and our class was creating a standout product; one that excels in at least one way. This allows the design to be more marketable and desirable to consumers, creating a “new, superior product,” as opposed to a “pretty good” product.

The scoring process was conducted differently than the screening process. Instead of each member scoring and averaging them together, the scoring process was done together as a group. This was done because it is crucial that the percentages all add up to 100% and the number values stay constant. Doing scoring together also allowed the group to talk through the ideas

more thoroughly, seeing how each member saw each idea beyond a -1, 0, or 1 number value. Table II (below) is the scoring summary created after discussing and calculating the values.

Group 3: Solar Panel Cleaning System Joshua Belisle, Brandon Bonner, Nick Langer, Kyleigh Talomie		Design 1		Design 2		Design 3		Design 4		Design 5	
		Moving/Rolling Brush		Water Sprinkler		Sprinkler and Wiper System		Rolling Charged plate w/ Sprinklers		Pool Cover w/ Charged Plate	
Criteria	Weighting	Rating	Weighted Score	Rating	Weighted Score	Rating	Weighted Score	Rating	Weighted Score	Rating	Weighted Score
Hide Ability	10.00%										
Out of 45 deg zone	10.00%	1	10.00%	1	10.00%	1	10.00%	1	10.00%	1	10.00%
Weather Adaptable	20.00%										
Sun	5.00%	1	5.00%	1	5.00%	1	5.00%	1	5.00%	1	5.00%
Water	5.00%	1	5.00%	1	5.00%	1	5.00%	1	5.00%	0	0.00%
Snow	5.00%	0	0.00%	-1	-5.00%	-1	-5.00%	-1	-5.00%	0	0.00%
Wind	5.00%	1	5.00%	1	5.00%	1	5.00%	1	5.00%	1	5.00%
Cost	1.00%										
Cheap	1.00%	0	0.00%	-1	-1.00%	-1	-1.00%	-1	-1.00%	0	0.00%
Operation	15.00%										
angled from 0-35 deg	15.00%	1	15.00%	1	15.00%	1	15.00%	1	15.00%	1	15.00%
Installation	9.00%										
Easy	2.00%	1	2.00%	-1	-2.00%	-1	-2.00%	-1	-2.00%	1	2.00%
Repeatable	2.00%	1	2.00%	1	2.00%	1	2.00%	1	2.00%	1	2.00%
Safe	5.00%	1	5.00%	1	5.00%	1	5.00%	0	0.00%	1	5.00%
Mechanical Simplicity	10.00%										
Number of components	5.00%	0	0.00%	1	5.00%	-1	-5.00%	-1	-5.00%	0	0.00%
Moving parts	5.00%	0	0.00%	0	0.00%	0	0.00%	0	0.00%	0	0.00%
Coverage Area	25.00%										
Cleans multiple at once	10.00%	0.5	5.00%	1	10.00%	1	10.00%	1	10.00%	1	10.00%
Cleans whole panel	15.00%	1	15.00%	1	15.00%	1	15.00%	1	15.00%	1	15.00%
Longevity	10.00%										
Cleaner itself	5.00%	1	5.00%	1	5.00%	1	5.00%	1	5.00%	1	5.00%
Doesn't damage panel	5.00%	1	5.00%	0	0.00%	0	0.00%	0	0.00%	1	5.00%
TOTAL	100.00%	11.5	79.00%	8	74.00%	6	64.00%	5	59.00%	11	79.00%

Table II. The Summary of Scoring the Top Five Ideas

As can be seen, both design 1 and design 5 scored a total score of 79%. The tie was an interesting realization for the group as it signified both ideas were better than the rest, yet both had beneficial and important qualities. Therefore, we decided to combine both ideas and create a rolling brush and charged plate system. The screening and scoring process allowed the group to come to this initial design idea and demonstrated its importance as the process provided a design idea that had not been initially considered.

Decision Making

The chosen design is a rolling brush and charged plate dual system. The dual cleaning method will allow the system to clean various types of solar panel inhibitors. The charged plate will be able to remove small dust and dirt particles, while the rolling brush will be able to remove larger items such as leaves, twigs, and bird droppings. This design will also be autonomous, allowing the system to be run without user supervision. Additionally, a dual lead screw and linear motion shaft system will allow the charged plate and brush to move over many solar panels in one run. This will allow a whole row of solar panels to be cleaned. The system will also be able to sit off to the side when not in operation, staying out of the occlusion zone. To further the details on the chosen design, let us specifically discuss three areas for which our group has conducted research and calculations.

Charged Plate Details

The charged plate was chosen in order to clean the solar panels because it does not use water. While we are unable to test the MIT technology ourselves, the published report from MIT provides the needed information on the charged plate system CITATION. The report begins by describing the efficiency decrease from dust covered solar panels. The findings are summarized in the graph below. As can be seen, the power output of the PV system is greatly decreased with even 5 mg/cm² of dust coverage.

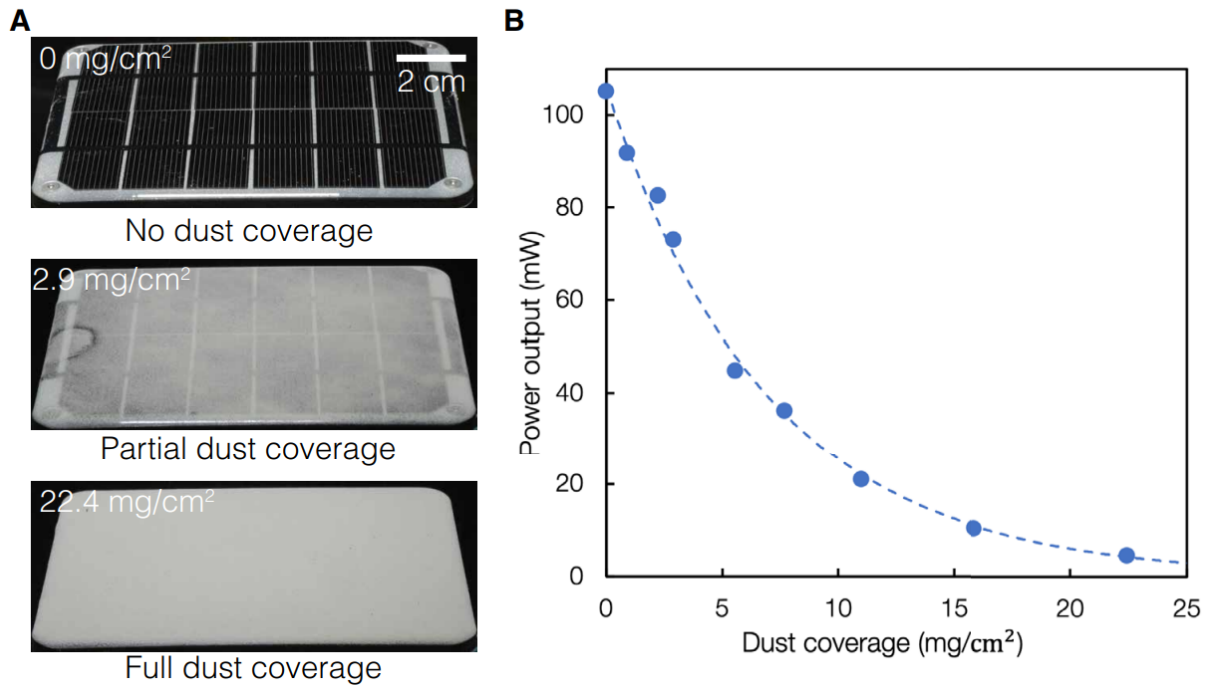

Figure 3. Power output (mW) decreases from dust coverage (mg/cm²).

The article continues on with the equations used to calculate the needed voltage to create a strong enough force to remove the dust particles. One of the key variables in the force needed is the average size of the dust particles. While the size can fluctuate, the study focuses on 4 main particle sizes (327, 256, 79, and 30 μm). The article also discusses the effects of humidity on the system. Humidity is needed for the system to induce the charge on the particles. According to the study, humidity above 30% is required for effective cleaning. In desert regions, daily humidity is below 30%, however at night, humidity drastically increases. The paper explains that because of the nightly humidity increase, the charged plate system could be used nightly to clean the panel surface. Then for other regions where humidity is on average above 30% even during the day, the system could be used whenever power output decreases a significant amount.

The paper discusses the lab prototype and then summarizes the result, which can be seen below. As can be seen from the graph, solar panel percent power output increases to above 95% for particles larger than 30 μm.

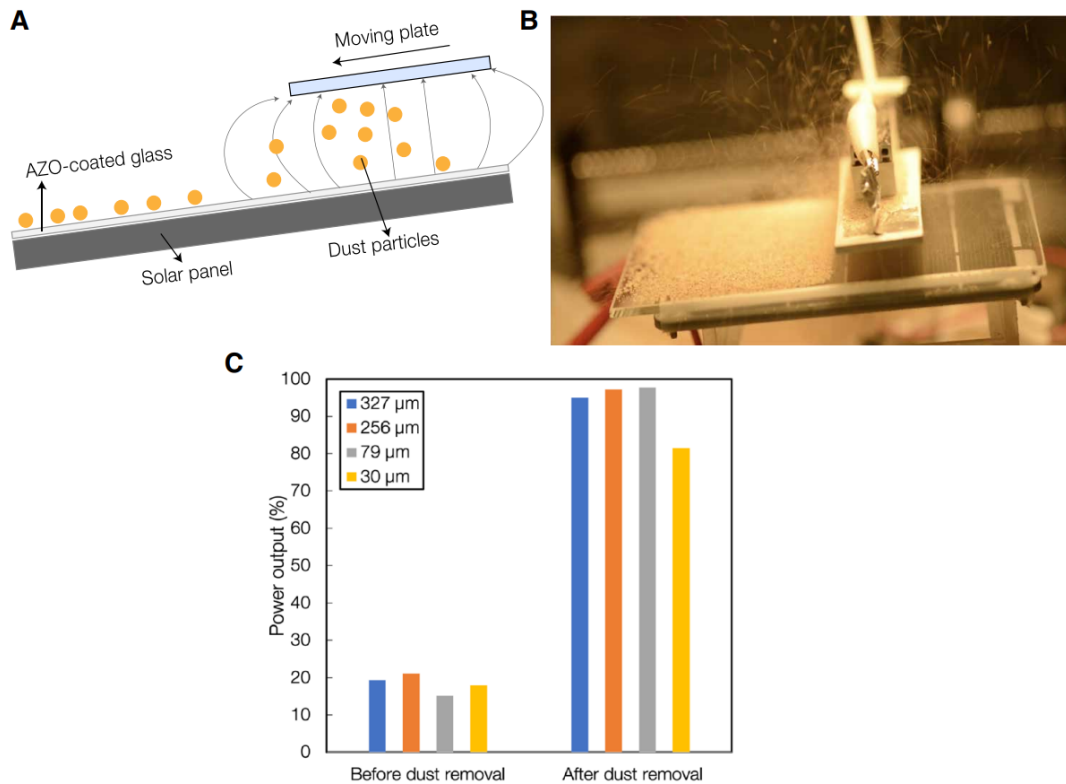

Figure 4. Summarized results for the charged plate solar panel cleaner. As can be seen, Percent Power Output for various particle sizes increases significantly after use of the cleaning system.

Because of the findings discovered by the MIT researchers, our group decided that this new technology would be an integral aspect of the design. The elimination of water usage along with the daily usability of the system were key factors in our decision to implement this into our system.

In addition to the charged plates cleaning ability, it must also be theoretically usable in our system. One major concern was to ensure the charged plate would not deflect too much under load and scratch the solar panel surface. The ideal spacing is 0.787 inches (or 2 cm) of space between the panel and plate. This means the design must be able to remain properly spaced while under load. The most common expected load would be from snow or icy conditions. Other loads would result in complete system failure, and thus are not being considered (such as fallen tree limbs).

To perform this analysis, some assumptions must be made. The first assumption is that the charged plate performs as a beam in bending under load. The next is the plate will be fixed at both ends, allowing the fixed beam under load equations to be used. And lastly, the snow will perform like a uniformly distributed load weighing 15 lbs/ft³, allowing the following equation to be used:

$$y_{max} = \frac{q_1 l^4}{384 \cdot E \cdot I} \quad (1)$$

Equation 1 solves for the max deflection of a beam fixed at both ends based on the uniform load (q), length of the beam (l), Young's Modulus (E), and the moment of inertia (I). After determining the load of the snow, moment of inertia, and Young's Modulus, the max deflection when the charged plate is under load from snow is 0.000556 inches. This is well within the 0.787 inch of space needed to ensure the plate doesn't scrape or scratch the solar panel. This calculation was performed for the scaled down model, having a length of 20 inches. However, even in the full scale model, expected to have a length of 45 inches, is still within the 0.787 inch spacing (roughly 0.032 inches of deflection).

Movement Details

Initial conceptions involved a rack and pinion system for translating the plate and brush across the panel. This mechanism was chosen because it efficiently converts a motor's rotational torque into linear motion. The equation:

$$T_R = \frac{F d_m}{2} \left(\frac{l + \pi f d_m}{\pi d_m - f l} \right) [lb * in] \quad (2)$$

was used to calculate the nominal torque needed for the motor. We then sought a motor with at least twice this torque rating. Two separate DC brush motors were responsible for the brush and plate so that they could move independently. The motors were placed on each side of the panel so that one side of the brush or plate, having the rack and pinion, will drive the motion while the other is driven along a smooth rod. Issues were expected to arise for parallel, rectilinear movement, so the design was updated to a system of two leadscrews instead of rack and pinions.

Along with the change to lead screws, we moved both DC motors to the same side of the assembly in order to make the wiring simpler. The lead screws were staggered so that the brush is held higher than the plate and they will not interfere. Opposite each lead screw is a circular shaft that will support the non-driven side of the plate/brush as it slides along.

The program for moving the brush and plate were made in the C++ coding language using the Arduino integrated development environment (IDE). Once variables are initialized, the main section of the code consists of four while loops for each run state. Each run state runs one motor in one direction until a specified limit switch is hit. An Arduino shield with a built-in H-bridge motor driver chip was used to simplify wiring. See Appendix C for the code that the design runs on.

The four while loops function as follows. Once the start button is pressed, motor A, which is connected to the brush, begins to run with a full duty cycle. When the brush apparatus hits the first limit switch, the next run state is activated, stopping motor A and the brush and starting the motion of the plate with motor B. Once the second limit switch is reached, the plate

stops for a quarter of a second so that it can reverse and return to its starting position, setting off the third limit switch. At this point, motor A will then be activated so that the brush can move back as well. Once the fourth limit switch is pressed, the run state will return to its original value. The brush and plate alternate motion in this way so that the two won't cross each other.

Brush Details

As previously mentioned, the rolling brush component of our design will serve to remove large debris and scrub trouble spots on the panel that cannot be addressed by the charged plate. Extensive online research has highlighted potential brush characteristic options, including brush type, fiber material, bristle type, handle material, etc. There are three central considerations that must be prioritized when selecting the particular characteristics of the brush: material hardness, material durability, and susceptibility to debris buildup.

The tempered glass typically used in solar panels is approximately 5.5-6 on the Mohs hardness scale, which is a scale utilized to quantify the scratch resistivity of a material that ranges from 1 to 10, 10 being the hardest ("Glass," n.d.). The fiber material we select must fall below 5.5 on the Mohs hardness scale to ensure that the brush will not scratch the panel surface. Any scratch on the panel could drastically reduce the energy production capacity and overall efficiency of the panel. Additionally, all brush components must be durable and have the ability to withstand all weather conditions without rusting, deteriorating, or breaking; it is important to ensure the brush will not require frequent replacement or upkeep. Factors like tensile strength, strength-to-density ratio, impact resistance, and melting point are strong indicators of durability and weather-resistance (*Cleaning Brush: What Is It? How Is It Made? Types & Uses*, n.d.). Lastly, the brush must reduce debris buildup within the bristles as much as possible; any buildup of fine dust or dirt could dramatically reduce the cleaning capability of the brush, and buildup of larger debris could increase scratching. An anti-static brush with low to moderate water absorption would help to minimize harmful debris accumulation.

Given a brush cannot be easily constructed or 3D-printed with the provided resources, it is necessary to determine a plan to implement the brush into the final design prototype. The idea of using a vacuum beater bar was explored, as they typically have excellent fatigue life, abrasion resistance, low to moderate water absorption, anti-static properties, and a strong bend recovery rate (*Cleaning Brush: What Is It? How Is It Made? Types & Uses*, n.d.).

While a vacuum beater bar would be an ideal choice for a fully formed prototype, we ultimately decided to utilize a paint brush roller for the proof of concept. The paint brush roller could be easily purchased while also being easily integrated into the proof of concept. The paint brush roller also has many benefits as it is made of high density polyester, can brush many various types of debris, and rolls with minimal force. Because it is soft enough and easily implemented into the proof of concept cheaply, a paint brush roller was utilized in the final design.

Standards

The standards around solar panel cleaning are minimal. Because the current method of cleaning simply uses water and cleaning solution, standards have yet to be fully realized for solar panel cleaners. However, solar panels themselves have regulations for domestic and commercial installations. For domestic installations in Virginia, it is illegal for Homeowner Associations (HOAs) to ban solar panels installations on private property unless it was clearly stated in the association's declaration (Main et al., 2020). As of new laws in 2022, communities can restrict the size and placement of solar panels and place reasonable restrictions on such systems (*Update on Virginia Law*, 2022). These limitations to the sizing of domestic solar systems in Virginia would also apply to our cleaning system. This means our design must not take up excessive space. Our system will also need to be easily incorporated into previously built systems as well and not make those systems too large as they most likely will have already utilized most of the allowable space. Our system will also need to be flexible for varying standards, as each HOA creates its own criteria.

Risk Analysis

Certain risks were considered for both the mechanical and electrical components of the final design. For the Arduino and H-bridge motor driver, the mechatronic system was modeled in TinkerCAD before moving on to real-world testing. This prevented melting of sensitive components in charge of the logic in the system. For the motors, we desired to keep them from stalling and thus overheating. For this reason two safety measures were incorporated into the project. The stop button can be pressed by the customer at any time to halt both motors, stopping the brush and plate in their place. Furthermore, the reset button, when pressed, will return both cleaning mechanisms to their original positions. A future iteration could involve current sensors in series with the motors. If the motor begins to draw a value of current that indicates stalling, the system could be coded to automatically stop or reset the motors.

Solution

Final Solution

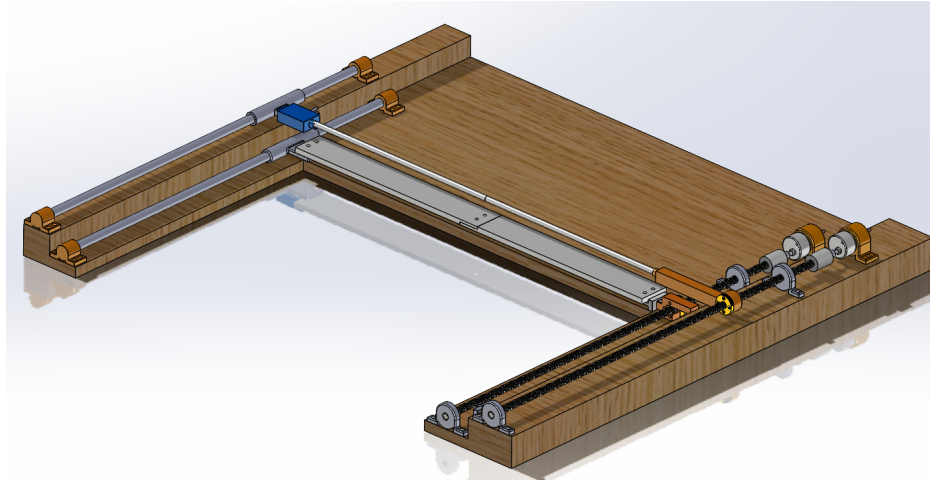

Figure 5. Finalized CAD for our proposed design

Our design utilizes a U-shape frame with a double lead screw and linear motion shaft system. The two DC brush motors drive the lead screws, allowing for separate motion for the charged plate and brush. The linear motion shafts help stabilize the other side of the brush and plate as they move. The system works by having the brush move first, gliding across the solar panel until reaching the limit switch at the end. The limit switch is pressed, stopping the brush and starting the charged plate. The charged plate moves until it hits another limit switch at the end, causing it to return to its original spot and hitting a third limit switch. This returns the brush, going until it hits the fourth and final limit switch, ending the cleaning process and stopping all components.

The U-shape frame was chosen because this design could be easily expanded and implemented for multiple panels. The U-shape allows the system to be slid around the solar panel and secured into place. It could also be extended to any desired length to clean multiple solar panels in one cleaning period. The other benefit is this design incorporates an easy place for the brush, plate, and electronics to sit outside of the occlusion zone when not in use.

As previously mentioned, the main cleaning methods for our design are the MIT charged plate (modeled with ABS plastic) and a rolling brush. The charged plate will be able to clean the smaller soilers, such as dirt and dust. The rolling brush will be able to clean the larger items such as leaves, twigs and bird droppings. The brush was not modeled in CAD, as we bought a paint roller for our proof of concept. However, what can be seen is the bar that goes down the middle of the paint roller, connecting both sides and helping move the brush. This bar was utilized as

opposed to attaching the paint roller directly for ease of replacement and it allows the brush to spin as it moves.

Overall, our design meets the desired criteria and specifications. It would be able to clean the entire solar panel, the system sits outside of the occlusion zone when not in use, it is relatively cheap over the course of its lifetime, as it would not need much maintenance and is a one time purchase. The system would also be able to operate on various angles and weather conditions, allowing it to be utilized in various environments. The system would also be safe, no longer requiring humans to get on roofs to clean panels and be securely fastened around multiple panels. Lastly, this system utilizes the new MIT charged plate, allowing it to be water free and a better alternative than the current method of water and solution.

Public Health & Safety

Once installed by a professional, this system will keep customers from having to periodically clean their panels. The actual design would include a pushbutton or app that could be accessed from ground level in order to activate cleaning services. This can be considered a major benefit over not having such a system, which could lead to a customer falling off a roof if they take on the challenge of cleaning their panels themselves.

Global, Social, Cultural, and Environmental Factors

The nature of this project lends itself well as a sustainable solution to renewable energy technology. Systems adjacent to renewable energy must also take into account environmental considerations. According to MIT, current techniques are estimated to use around 10 billion gallons of water each year (Chandler, 2022). These techniques often include soap and water. For this reason MIT developed an electrified plate that attracts dust particles without the need to waste precious clean water resources. This design also prevents water pollution that could arise from cleaning solutions as runoff eventually leaches into groundwater.

Unfortunately, solid waste may be produced when the design completes its life cycle and must be discarded. While reuse of the brush and plate prevent scrap production over the life of the device, they will eventually have to be thrown away. For this reason, the cleaning system should be sorted by the user so that the components can be recycled as much as possible. Regarding other environmental factors, the system will have little to no negative impact on air pollution, land degradation, biodiversity, and ozone depletion.

Cost Analysis

As specified at the beginning of this project, our solution needed to be low cost and marketable. Our group used a budget sheet to track all of the made and purchased parts through the project (Appendix B). The total cost of our project was \$316.72, well under the total budget

of \$780. The main costs for our system were the lead screw assemblies. We decided to buy full assemblies as opposed to individual parts for ease of manufacturing. We also incurred costs through the testing phase as some parts broke or needed to be redesigned. However, because our design uses 3D printed parts, these additional costs were small.

If our design were to be furthered and made into a commercial product, our costs would increase. Our design incorporates a U-shape frame so it could be attached to an entire row of solar panels. The system would thus need longer lead screws and shafts, driving the costs up. In addition, some of the 3D printed parts would need to be made out of more durable material, also increasing costs. However, despite the price being increased, our design would be able to clean multiple solar panels and need minimal inspection and maintenance. Our device would be a large up front cost to customers, most likely around \$500. However, the system would be cheaper in the long run with minimal upkeep, no recurring payments, cleaning multiple panels at once, and being able to be run daily for maximum solar panel efficiency. These cost saving factors would make our design a cheaper alternative than current water based solutions.

Conclusion

The first improvement would be to get the system fully functioning all the time. Currently, the ABS plastic gets stuck on the linear motion shaft, stopping all movement. We believe that if a smoother material, such as metal, would be used for the journal bearings, the system would have consistent movement. In addition, the wiring needs to be soldered into place. The current wires are simply twisted at connection points, causing unreliable signals from the limit switches. The code works perfectly in TinkerCad, it is the physical model that needs proper connections to improve functionality. However, once these improvements are to be made, the system should work as a functioning proof of concept.

Future improvements can also be made to the system's weather resistance. While not required for a proof-of-concept, a mounted cleaner would be subject to wind, rain, and snow. The journal shafts are made of carbon-steel in our prototype because of the cost, but carbon-steel would rust in rooftop conditions. A different alloy, like stainless steel, should be considered to mitigate rusting. Additionally, a housing for the electronics and Arduino would keep them safe from the elements.

With future work, the microcontroller can be further utilized by optimizing the system to run when needed, rather than by user input. A plate that is activated each time runs the risk of wasting energy when it is not needed. For example, the electric plate should not run when, during, or immediately after a rainstorm, but the brush may be helpful. One way to track the accumulation of dust is by recording the power output of the solar array. This past information can be stored in the "integral," while an overall downward trend in output can be stored in the

“derivative” of a proportional-integral-derivative (PID) controller. If the power output lessens over time, the microcontroller will cause the brush and/or plate to run after a set threshold is reached. This threshold would compare the predicted versus actual output of the panel. Overall, such a feature would optimize energy use and save on operating costs.

Appendices

Contributions to the Project:

Brandon Bonner: Background Research, Motors, CAD Design, Mechatronics, Construction

Joshua Belisle: Background Research, Charged Plate, CAD Design, Budget, Construction

Nick Langer: Background Research, CAD Design, 3D Printing, Budget, Construction

Kyleigh Talomie (Fall 2022 Semester): Background Research, Brush Analysis

Appendix A: Calculations for Charged Plate Deflection

<https://www.desmos.com/calculator/3u2by1ot5s>

Appendix B: Budget Sheet

Part	Buy or Make	Distributor	Unit Price	Quantity	Total Price	Final Price	Bought?	Received?
Lead Screw Assembly	Buy	https://vxb.com/product	\$57.44	2	\$114.88	\$114.88	Y	Y
DC Motor	Buy	https://www.jameco.com	\$19.95	2	\$39.90	\$39.90	Y	Y
Arduino Motor Shield Rev3	Buy	https://store-usa.arduino.cc	\$27.60	1	\$27.60	\$27.60	Y	Y
Limit Switches (12 pack)	Buy	https://www.amazon.com	\$6.49	1	\$6.49	\$6.49	Y	Y
Limit Switch Screws	Buy	https://www.homedepot.com	\$1.38	1	\$1.38	\$1.38	Y	Y
Journal Shaft (10 mm Dia)	Buy	https://www.mcmaster.com	\$18.31	2	\$36.62	\$36.62	Y	Y
Arduino Uno R3	Buy	https://store-usa.arduino.cc	\$27.60	1	\$27.60	\$27.60	Y	Y
Wooden Base	Buy	Lowes	\$18.25	1	\$18.25	\$18.25	Y	Y
Paint Brush	Buy	Lowes	\$10.00	1	\$10.00	\$10.00	Y	Y
First Round 3D Printing	Make	UVA	\$4.59	1	\$4.59	\$4.59	Y	Y
Second Round 3D Printing	Make	UVA	\$4.11	1	\$4.11	\$4.11	Y	Y
Third Round 3D printing	Make	UVA	\$3.23	1	\$3.23	\$3.23	Y	Y
Fourth Round 3D print	Make	UVA	\$1.07	1	\$1.07	\$1.07	Y	Y
Fifth Round 3D print	Make	UVA	\$10.44	1	\$10.44	\$10.44	Y	Y
Sixth Round 3D Print	Make	UVA	\$1.80	1	\$1.80	\$1.80	Y	Y
#6 1/2 in Screws	Buy	Lowes	\$2.19	2	\$4.38	\$4.38	Y	Y
#6 1 in Bolt and nuts	Buy	Lowes	\$2.19	1	\$2.19	\$2.19	Y	Y
#4 3/4 in Bolts and nuts	Buy	Lowes	\$2.19	1	\$2.19	\$2.19	Y	Y
\$316.72								

Appendix C: Arduino Code

```
//May 5, 2023 - Brandon Bonner
```

```
//direction, speed, and brake pins for motors A & B
```

```
const int dirPinA = 12;
const int pwmPinA = 3;
const int brakePinA = 9;
```

```
const int dirPinB = 13;
const int pwmPinB = 11;
const int brakePinB = 8;
```

```
//start, stop, and reset pins
const int startPin = 7;
const int stopPin = 10;
const int resetPin = 1;

//Limit Switches
const int LS1 = 6;
const int LS2 = 5;
const int LS3 = 4;
const int LS4 = 2;

//each runState will "tell" which motor to run
int runState = 0;

//initialize motor speeds
int speedA = 0;
int speedB = 0;

//motors are called as single characters in the move function
char motorA = 'A';
char motorB = 'B';

//inputs for move function
char motor;
String dir[3];

void setup() {

    //pwm speed and direction pins
    pinMode(dirPinA, OUTPUT);
    pinMode(pwmPinA, OUTPUT);
    pinMode(brakePinA, OUTPUT);

    pinMode(dirPinB, OUTPUT);
    pinMode(pwmPinB, OUTPUT);
    pinMode(brakePinB, OUTPUT);

    //start, stop, and reset are input pins
    pinMode(startPin, INPUT);
```

```
digitalWrite(startPin,LOW);
pinMode(stopPin, INPUT);
digitalWrite(stopPin,LOW);
pinMode(resetPin, INPUT);
digitalWrite(resetPin, LOW);
```

```
//limit switches are input pins
pinMode(LS1,INPUT);
digitalWrite(LS1,LOW);
pinMode(LS2,INPUT);
digitalWrite(LS2,LOW);
pinMode(LS3,INPUT);
digitalWrite(LS3,LOW);
pinMode(LS4,INPUT);
digitalWrite(LS4,LOW);
```

```
//Serial.begin(9600); //uncomment for debugging runStates with print statements; don't use pin
1 for resetting
}
```

```
void loop() {
```

```
  //Serial.println(runState);
```

```
  while (runState = 0) {
    halt();
    reset();
  }
```

```
  if (digitalRead(startPin) == HIGH) {
    runState = 1;
  }
```

```
  while (runState > 0 && runState < 5) {
```

```
    //run motor A CW until it hits LS1
    while (runState == 1) {
      //Serial.println(runState);
      reset();
```

```
move(motorA,"CW");
if (digitalRead(stopPin) == HIGH) {
  halt();
  runState = 0;
}
else if (digitalRead(LS1) == HIGH) {
  halt();
  runState += 1;
}
}
```

```
//run motor B CW until it hits LS2
while (runState == 2) {
  //Serial.println(runState);
  reset();
  move(motorB,"CW");
  if (digitalRead(stopPin) == HIGH) {
    halt();
    runState = 0;
  }
  else if (digitalRead(LS2) == HIGH) {
    halt();
    delay(250); // wait .25 sec so motor can reverse
    runState += 1;
  }
}
```

```
//run motor B CW until it hits LS3
while (runState == 3) {
  //Serial.println(runState);
  reset();
  move(motorB,"CCW");
  if (digitalRead(stopPin) == HIGH) {
    halt();
    runState = 0;
  }
  else if (digitalRead(LS3) == HIGH) {
    halt();
    runState += 1;
  }
}
```

```

}

//run motor A CW until it hits LS4
while (runState == 4) {
  //Serial.println(runState);
  reset();
  move(motorA,"CCW");
  if (digitalRead(stopPin)|| digitalRead(LS4) == HIGH) {
    halt();
    runState = 0;
  }
}
}
}
}

```

```

void move(char motor, String dir) {
  if (motor == 'A') {
    speedA = 255;
    speedB = 0;
    if (dir == "CCW") {
      digitalWrite(dirPinA,HIGH);
      digitalWrite(brakePinA,LOW);
      digitalWrite(brakePinB,HIGH);
      analogWrite(pwmPinA,speedA);
      analogWrite(pwmPinB,speedB);
    }
    else if (dir == "CW") {
      digitalWrite(dirPinA, LOW);
      digitalWrite(brakePinA,LOW);
      digitalWrite(brakePinB, HIGH);
      analogWrite(pwmPinA,speedA);
      analogWrite(pwmPinB,speedB);
    }
  }
  else if (motor == 'B') {
    speedA = 0;
    speedB = 255;
    if (dir == "CCW") {
      digitalWrite(dirPinB,HIGH);
      digitalWrite(brakePinA,HIGH);
    }
  }
}

```

```

    digitalWrite(brakePinB,LOW);
    analogWrite(pwmPinA,speedA);
    analogWrite(pwmPinB,speedB);
}
else if (dir == "CW") {
    digitalWrite(dirPinB, LOW);
    digitalWrite(brakePinA,HIGH);
    digitalWrite(brakePinB,LOW);
    analogWrite(pwmPinA,speedA);
    analogWrite(pwmPinB,speedB);
}
}
}

void halt() { //stop both motors
    speedA = 0;
    speedB = 0;
    analogWrite(pwmPinA,speedA);
    analogWrite(pwmPinB,speedB);
}

void reset() { //returns brush and panel to original position
    if (digitalRead(resetPin) == HIGH) {
        halt();
        delay(250);
        runState = 3;
    }
}
}

```

Appendix D: Motor Calculations (MATLAB)

Design Project

Motor Analysis

```
W = 2; %estimate of brush weight in pounds
```

```
W = 2
```

```
f = 0.4; %coefficient of friction
```

```
f = 0.4000
```

```
F = (1/2)*f*W; %axial compressive force
```

```
F = 0.4000
```

```
dm = 0.25; %mean diameter (inches)
```

```
dm = 0.2500
```

```
dm_SI = in_to_mm(dm);
```

```
dm_SI = 6.3500
```

```
l = .16; %lead (in)
```

```
l = 0.1600
```

```
T_R = 0.5*(F*dm)*(1+pi*f*dm)/(pi*dm-f*l); %Torque (lbin)
```

```
T_R = 0.0329
```

```
T_R_SI = lbin_to_Newtonmeter(T_R) %(Newton meters)
```

```
T_R_SI = 0.0037
```

```
T_R_gcm= T_R*178.579673 %gcm
```

```
T_R_gcm = 5.8688
```

Functions

```
function Newtonmeters = lbin_to_Newtonmeter(lbin)
Newtonmeters = lbin*.113;
end
```

```
function millimeters = in_to_mm(in)
millimeters = 25.4*in;
end
```

Appendix E: Bill of Materials

Part Number	Part Name	Quantity
1	Base	1
2	Lead Screw Assembly	2
3	Linear Motion Shaft	2
4	Journal Bearing	1
5	Bottom Journal Bearing	1
6	Connector	1
7	Paint Roller Rod	2
8	Plate	2
9	Bar Fastener	4
10	DC Brush Motor	2
11	Motor Mount	2
12	Motor Coupling	2
13	Top Nut Attachment	1
14	Bottom Nut Attachment	1
15	Plate Connector	1
16	#6 ½ Inch Screws	14
17	#6 1 Inch Bolt and Nuts	7
18	#4 ¾ Inch Bolt and Nuts	6
19	#6 1 Inch Screws	14

Appendix F: Part 1 – Base

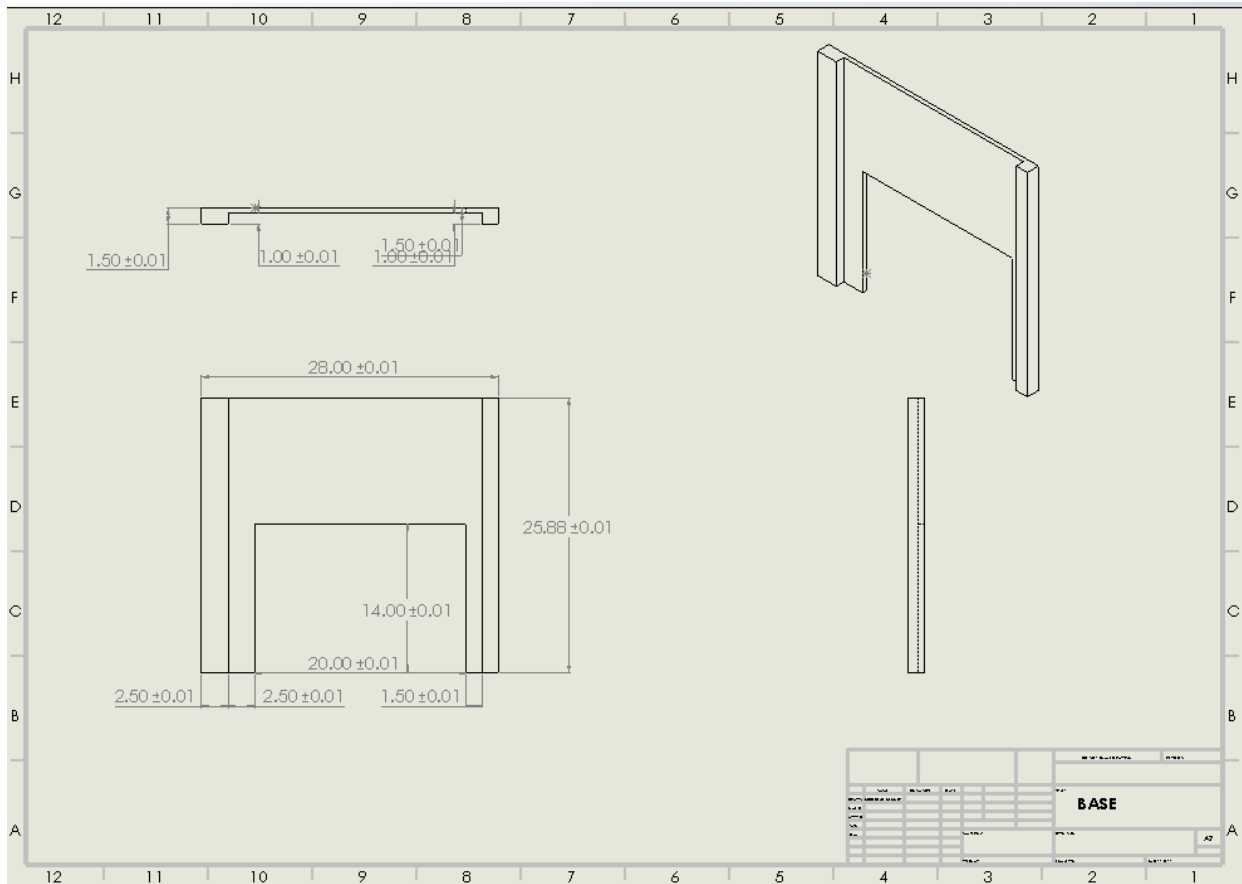

Appendix G: Part 2 – Lead Screw Assembly

Purchased:

https://vxb.com/products/500mm-t8-lead-screw-8mm-linear-motion-kit?variant=43582123376875&gclid=CjwKCAiA_vKeBhAdEiwAFb_nrZdBUTCP_xuUd13YURong1xPOgiyOinCVO5qVa-BUhwOfzzB8-mAsRoCtxQQAvD_BwE

Appendix H: Part 3 – Linear Motion Shaft

Purchased: Linear Motion Shaft, 1055 Carbon Steel, 10 mm Diameter, 500 mm Long

<https://www.mcmaster.com/metric-steel-rods/length~500-mm/for-motion-type~linear/>

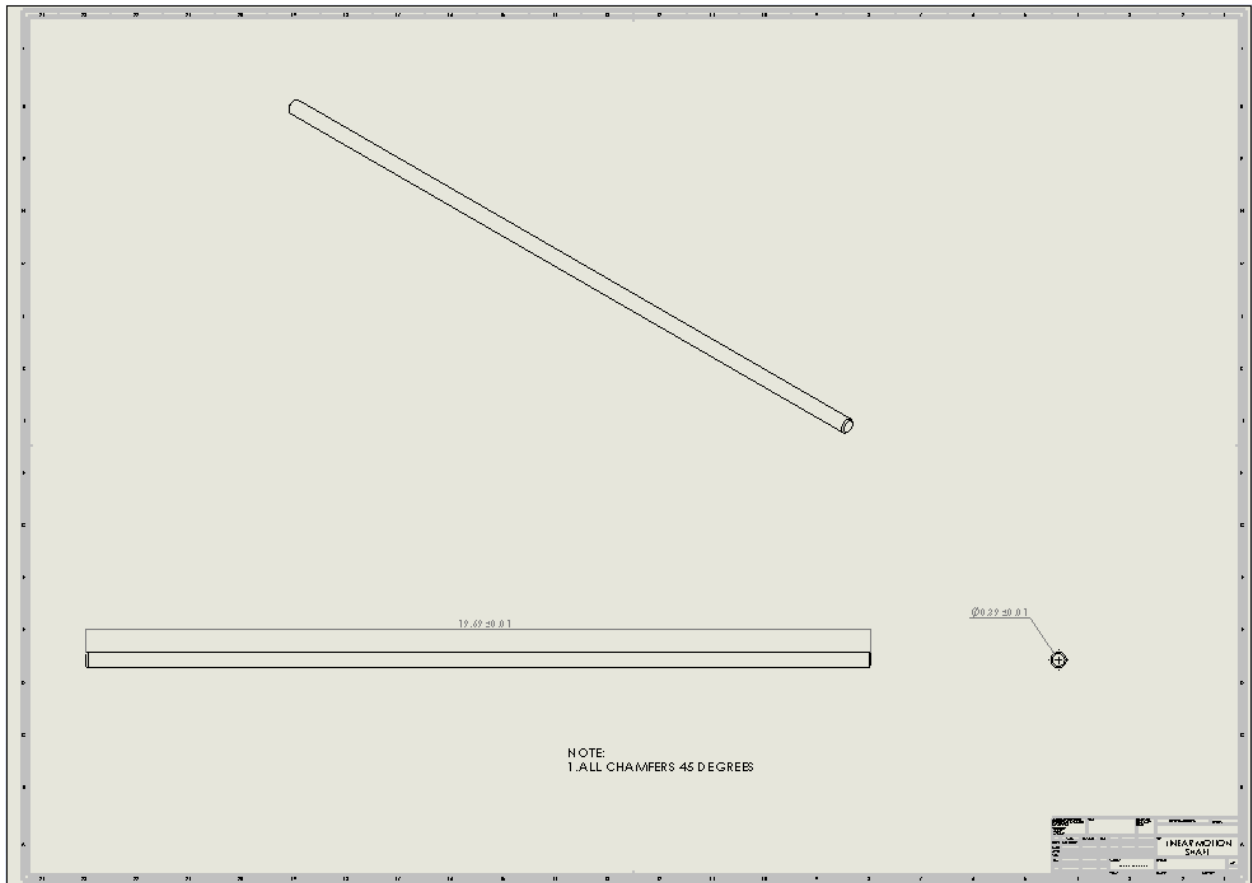

Appendix I: Part 4 – Journal Bearing

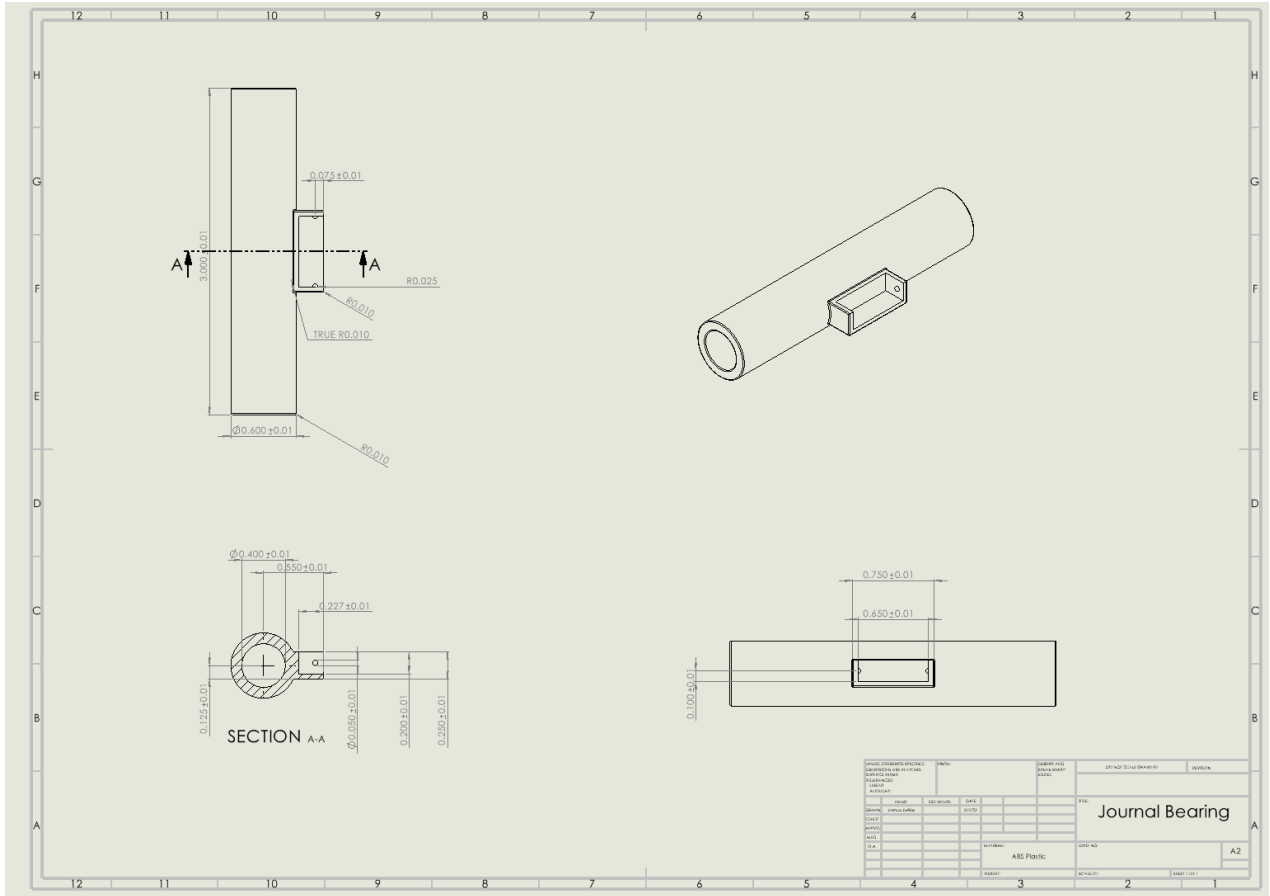

PARTS LIST		QUANTITY AND PRICE		DATE	
NO.	DESCRIPTION	QTY.	PRICE	DATE	BY
1	JOURNAL BEARING	1			
ABS Plastic					
				A2	

Appendix J: Part 5 – Bottom Journal Bearing

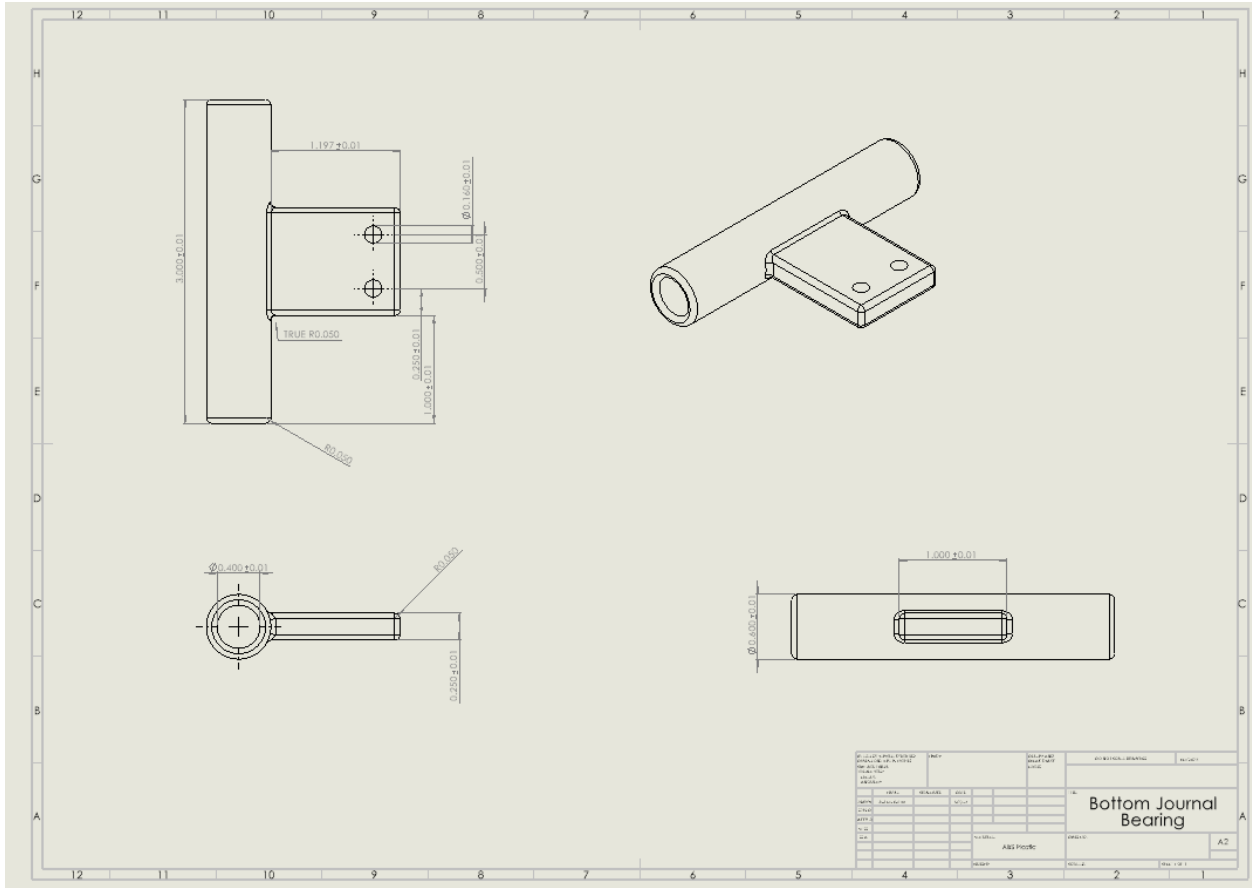

Appendix K: Part 6 – Connector

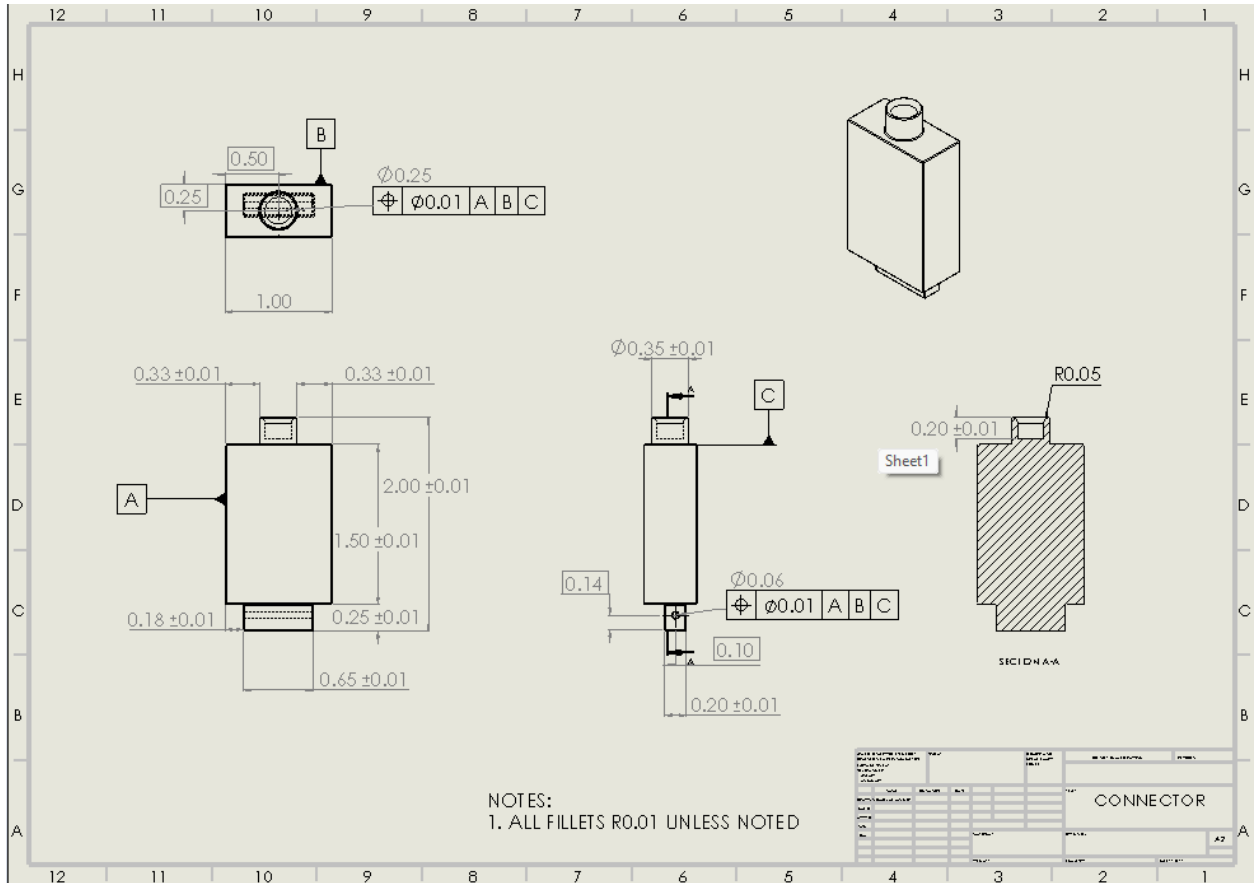

Appendix L: Part 7– Paint Roller Rod

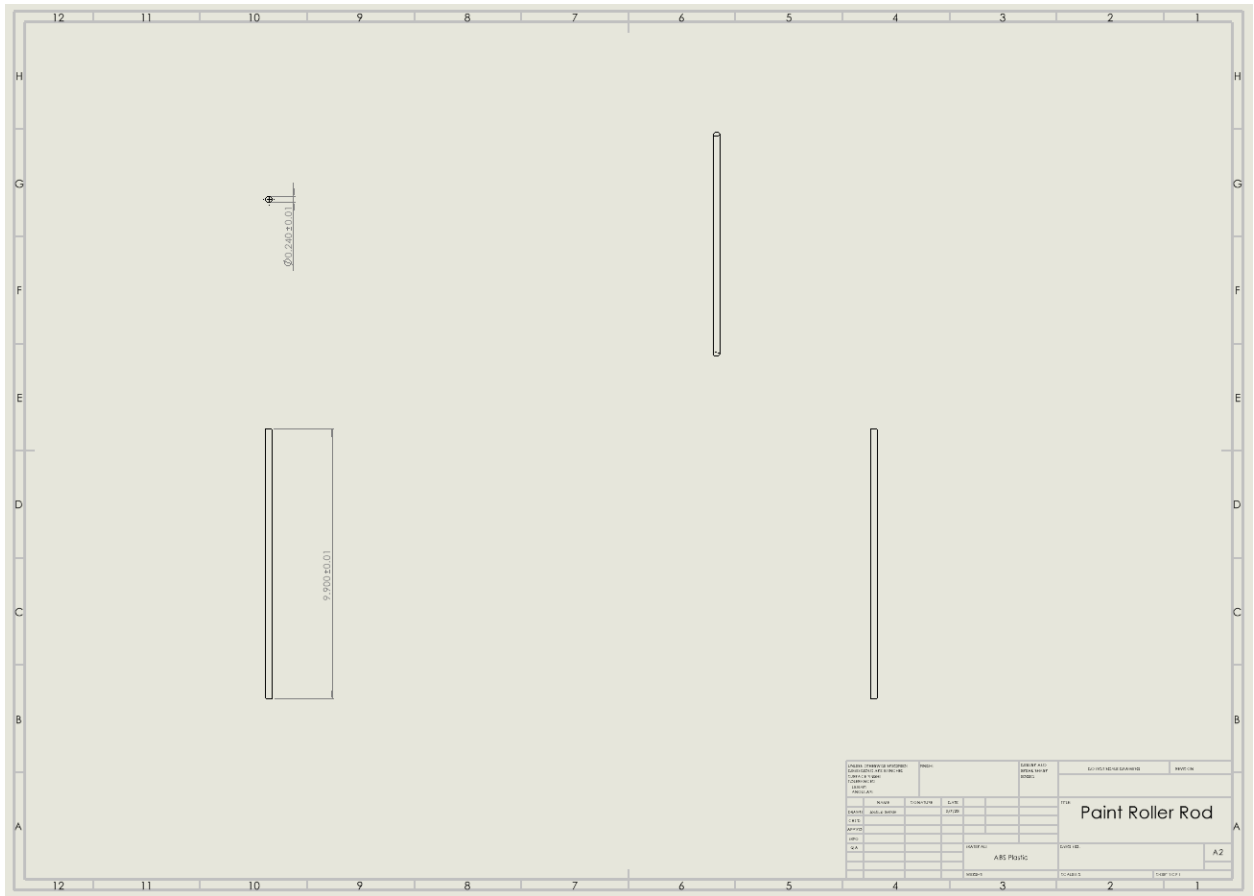

Appendix M: Part 8 – Plate

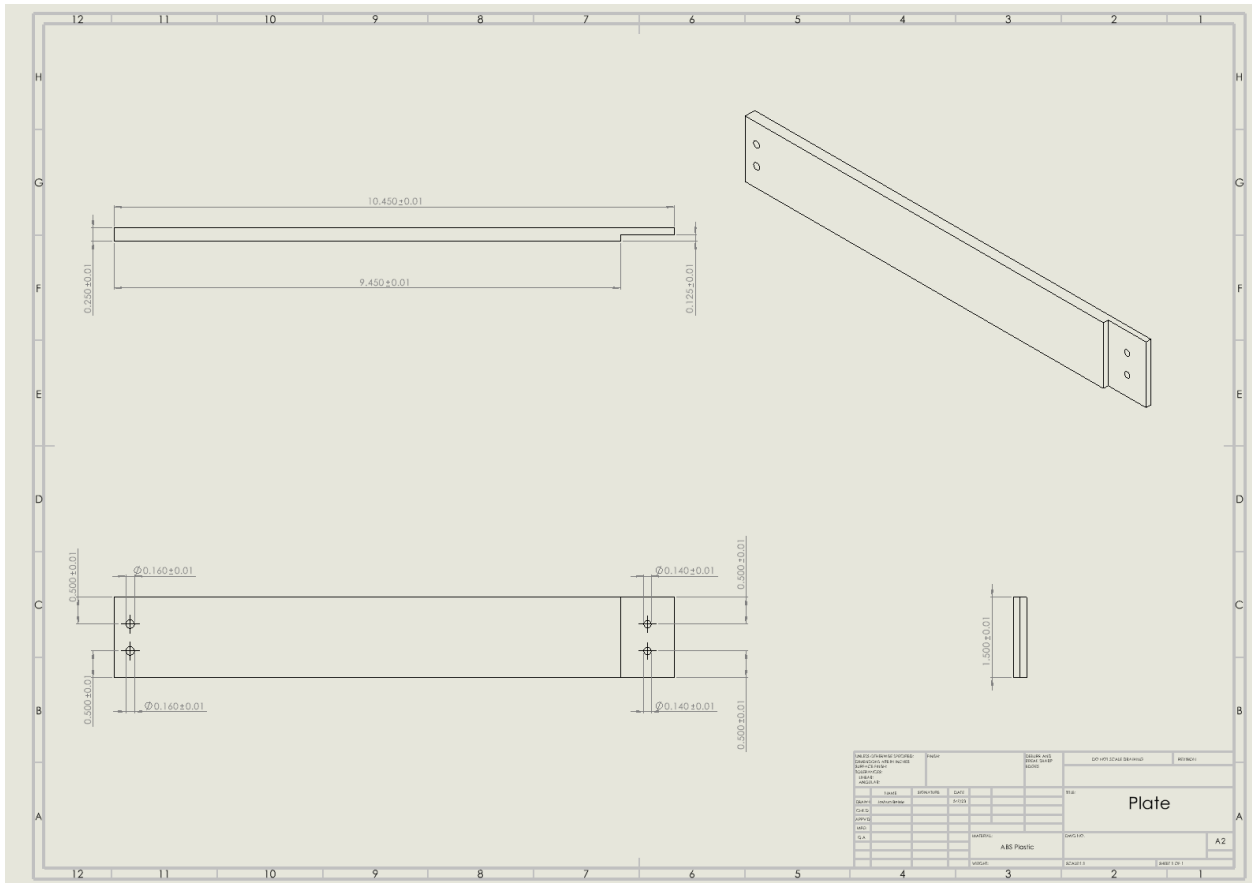

Appendix N: Part 9 – Bar Fastener

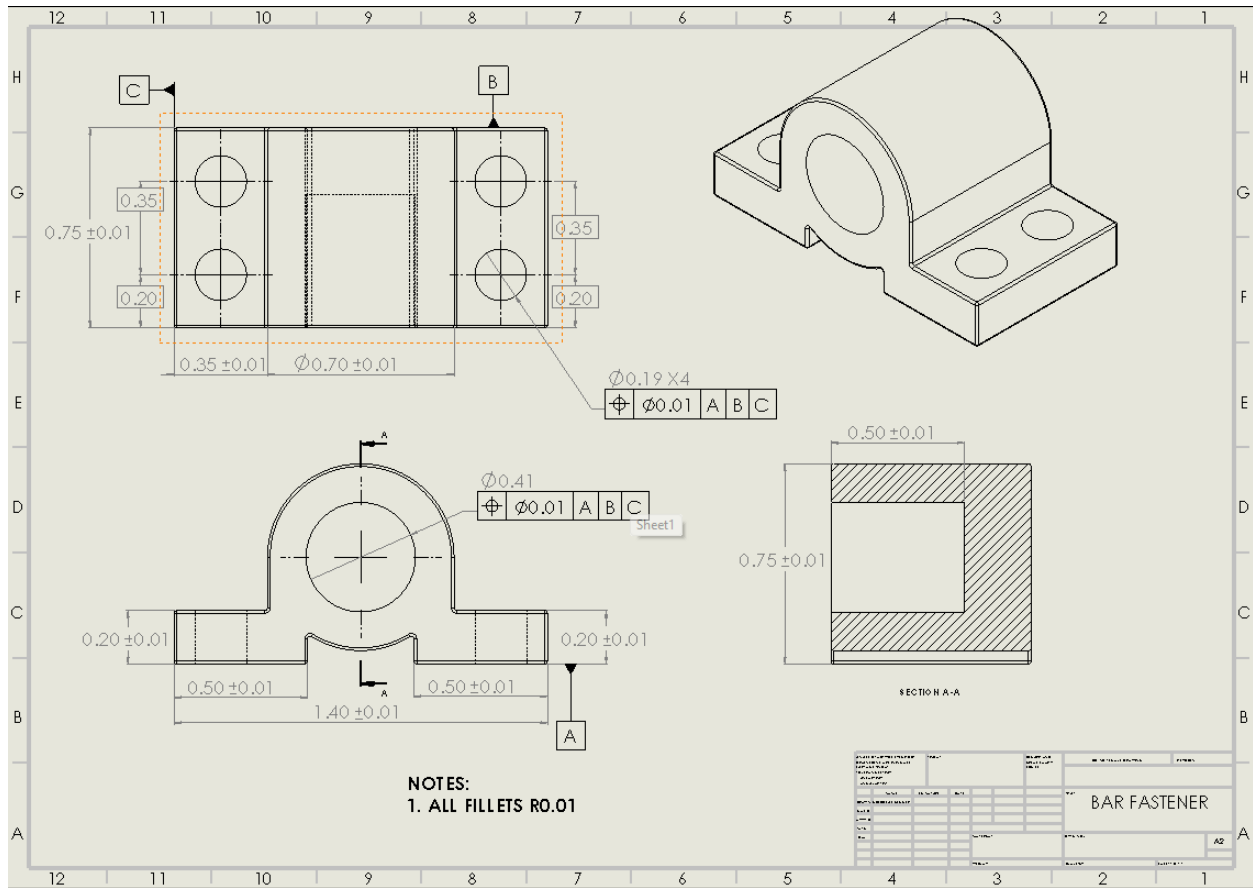

Appendix O: Part 10 – DC Brush Motor

Purchased:

https://www.jameco.com/z/HNGH12-1324Y-R-Jameco-ReliaPro-12V-Reversible-Gear-Head-DC-Motor-156mA_162191.html

Appendix P: Part 11 – Motor Mount

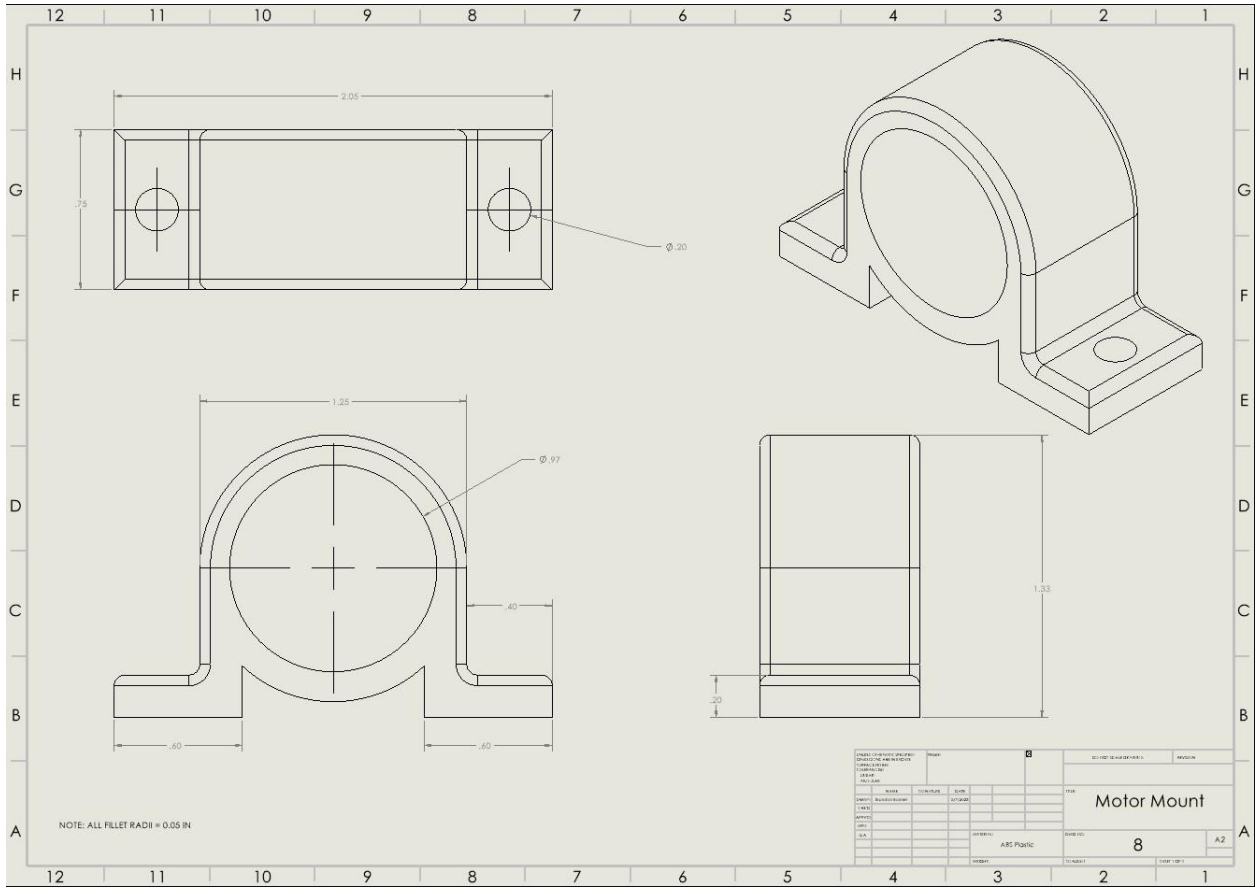

Appendix Q: Part 12 – Motor Coupling

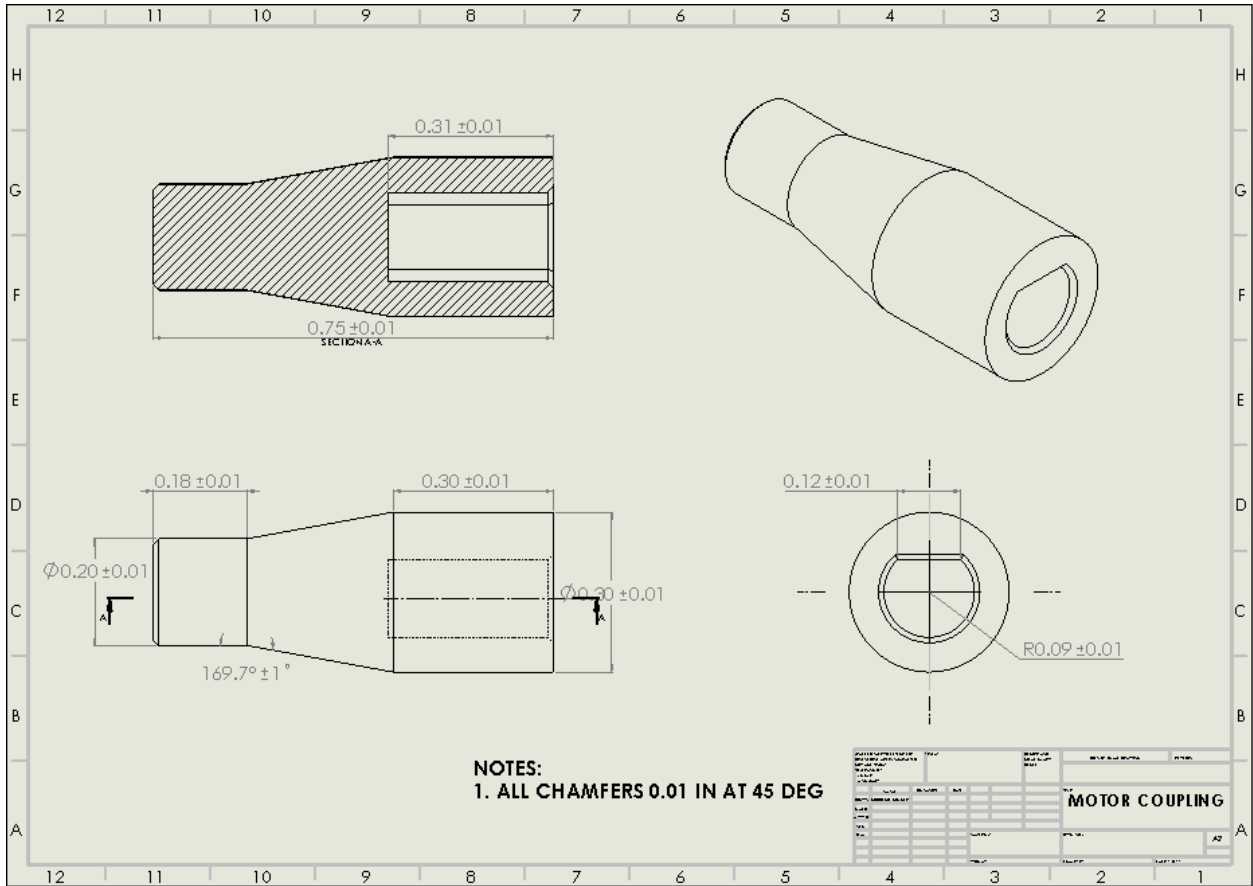

Appendix R: Part 13 – Top Nut Attachment

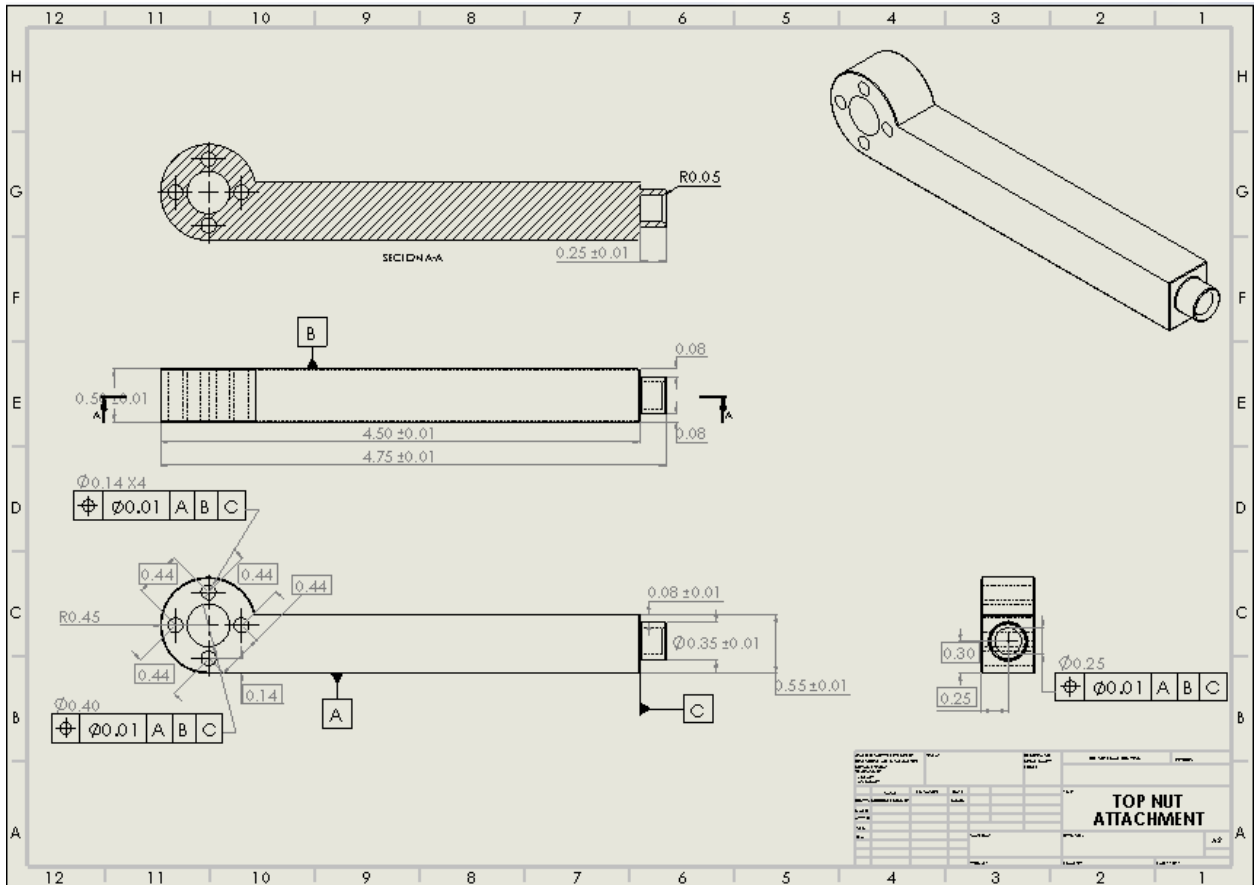

Appendix S: Part 14 – Bottom Nut Attachment

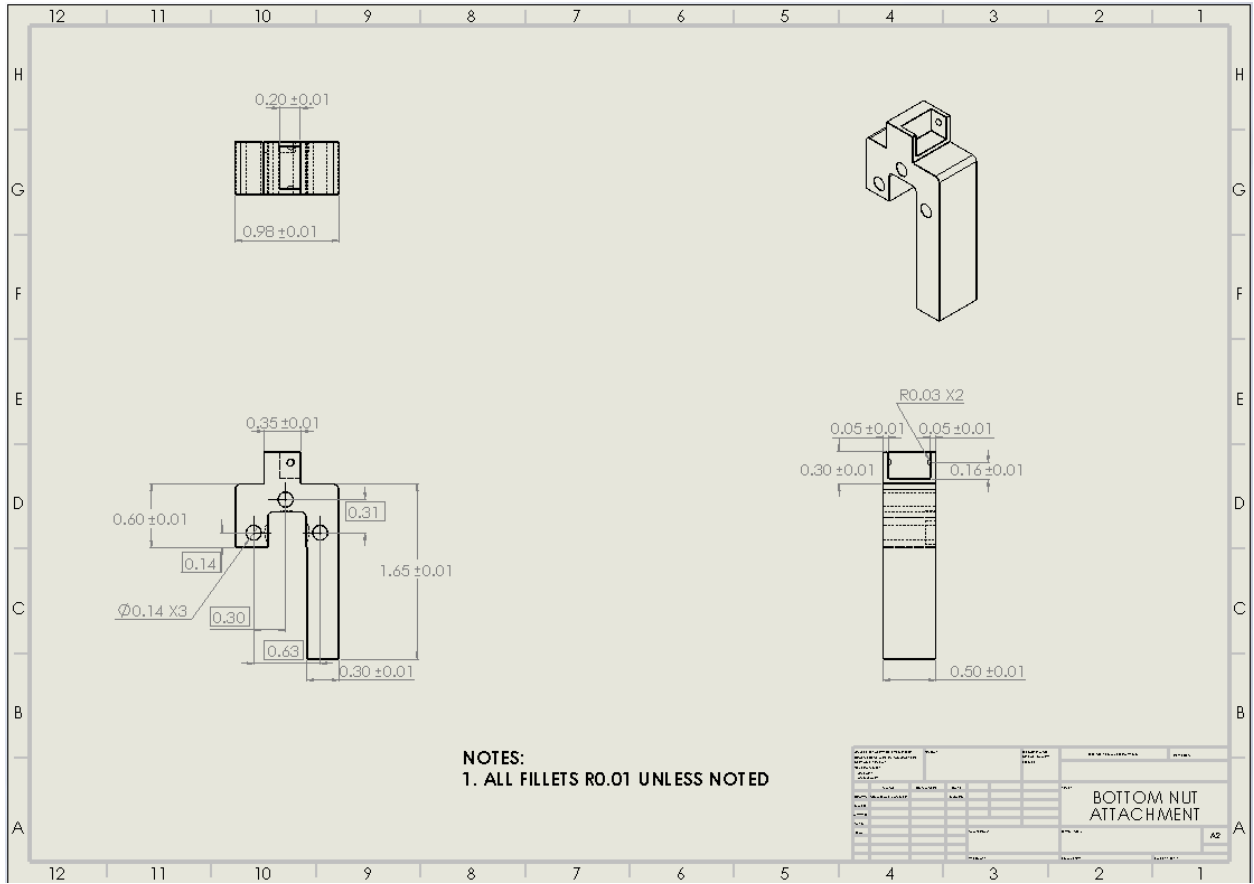

Appendix T: Part 15 – Plate Connector

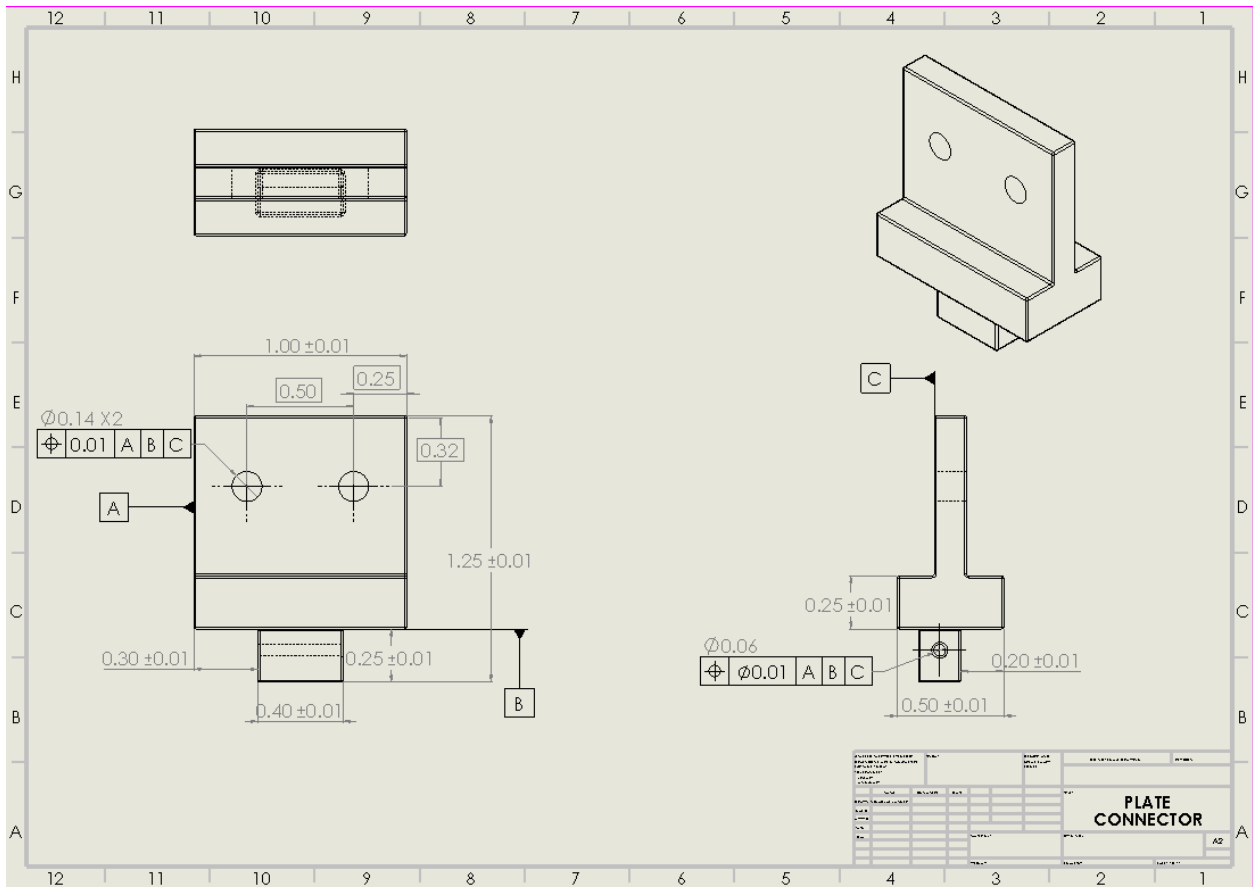

Appendix U: Part 16 – #6 ½ Inch Screws

Purchased: Lowes

Appendix V: Part 17 – #6 1 Inch Bolt and Nuts

Purchased: Lowes

Appendix W: Part 18 – #4 ¾ Inch Bolt and Nuts

Purchased: Lowes

Appendix X: Part 19 – #6 1 Inch Screws

Found: Leftover from previous personal work

References

- Asl-Soleimani, E., Farhangi, S., & Zabihi, M. S. (2001). The effect of tilt angle, air pollution on performance of photovoltaic systems in Tehran. *Renewable Energy*, 24(3), 459–468. [https://doi.org/10.1016/S0960-1481\(01\)00029-5](https://doi.org/10.1016/S0960-1481(01)00029-5)
- Chandler, D. (2022). How to clean solar panels without water. MIT News | Massachusetts Institute of Technology. Retrieved December 4, 2022, from <https://news.mit.edu/2022/solar-panels-dust-magnets-0311>
- Cleaning Brush: What Is It? How Is It Made? Types & Uses.* (n.d.). Retrieved December 13, 2022, from <https://www.iqsdirectory.com/articles/brush/cleaning-brush.html>
- Glass. (n.d.). *Solar Roadways*. Retrieved December 13, 2022, from <https://solarroadways.com/specifics/glass/>
- Hicks, W. (2021). Scientists Studying Solar Try Solving a Dusty Problem. Retrieved October 27, 2022, from <https://www.nrel.gov/news/features/2021/scientists-studying-solar-try-solving-a-dusty-problem.html>
- How To Clean Solar Panels To Reduce Energy Costs—Bob Vila.* (n.d.). Retrieved December 13, 2022, from <https://www.bobvila.com/articles/how-to-clean-solar-panels/>
- Maghami, M. R., Hizam, H., Gomes, C., Radzi, M. A., Rezadad, M. I., & Hajjghorbani, S. (2016). Power loss due to soiling on solar panel: A review. *Renewable and Sustainable Energy Reviews*, 59, 1307–1316. <https://doi.org/10.1016/j.rser.2016.01.044>
- Main, I., March 18, V. M., & 2020. (2020, March 18). New laws clear away barriers to small solar projects. *Virginia Mercury*. <https://www.virginiamercury.com/2020/03/18/new-laws-clear-away-barriers-to-small-solar-projects/>
- Panat, S., & Varanasi, K. K. (2022). Electrostatic dust removal using adsorbed moisture–assisted charge induction for sustainable operation of solar panels. *Science Advances*, 8(10), eabm0078. <https://doi.org/10.1126/sciadv.abm0078>
- Pickerel, K. (2020, May 4). *Dirty solar panels? Pro tip: Never use soap to clean.* Solar Power World. <https://www.solarpowerworldonline.com/2020/05/pro-tip-never-use-soap-to-clean-dirty-solar-panels/>

Update on Virginia Law: Covenants On Solar Panels. (2022, March 16). Chadwick, Washington, Moriarty, Elmore & Bunn, PC.

<https://www.chadwickwashington.com/2022/03/16/update-on-virginia-law-covenants-on-solar-panels/>