

Practical Exosuit Design for Patients with Amyotrophic Lateral Sclerosis

A Capstone Report
presented to the faculty of the
School of Engineering and Applied Science
University of Virginia

by

Ellianna Bailey

with

Patrick Evans
Priti Patel
Willis Williams
Lilly Xu
Nicholas Yantiss

May 12, 2023

On my honor as a University student, I have neither given nor received unauthorized aid on this assignment as defined by the Honor Guidelines for Thesis-Related Assignments.

Ellianna Bailey

Capstone advisor: Sarah Sun, Department of Mechanical and Aerospace Engineering

Practical Exosuit Design for Patients with Amyotrophic Lateral Sclerosis

Ellianna Bailey
Department of Mechanical and
Aerospace Engineering
University of Virginia
Charlottesville, VA
exb3dg@virginia.edu

Patrick Evans
Department of Mechanical and
Aerospace Engineering
University of Virginia
Charlottesville, VA
pje2mue@virginia.edu

Priti Patel
Department of Mechanical and
Aerospace Engineering
University of Virginia
Charlottesville, VA
pup8kwm@virginia.edu

Willis Williams
Department of Mechanical and
Aerospace Engineering
University of Virginia
Charlottesville, VA
wsw3zs@virginia.edu

Lilly Xu
Department of Mechanical and
Aerospace Engineering
University of Virginia
Charlottesville, VA
dx7gp@virginia.edu

Cole Yantiss
Department of Mechanical and
Aerospace Engineering
University of Virginia
Charlottesville, VA
ncy2j@virginia.edu

Abstract — The creation of fully soft, upper-limb exoskeletons for rehabilitation of patients with neuromuscular disorders, like ALS, is an emerging field of study and industry. These diseases affect millions worldwide, and the use of these robots is scarce because of lack of testing and research. Through this project, the group’s aim is to create a fully soft wearable robotic device that will be able to assist patients with activities of daily living. By using IMU and EMG sensors, a cable actuator, and computer programming, a novel device will be created with the intention of furthering this area of research and providing solutions for affected persons.

Keywords—ALS, EMG, IMU, degrees of freedom, exosuit, exoskeleton, neuromuscular disorder, ADL, upper-limb, TCPA, Bowden cable

I. INTRODUCTION

Neuromuscular disorders include a range of diseases that affect the nerves that control muscles, the muscles themselves, and the communication between the nerves and muscles [1]. In a study of epidemiologic data of thirty individual neuromuscular disorders spanning over 150 reported studies, the prevalence of neuromuscular disorders as a group is 100-300 per every 100,000 people [2]. Amyotrophic lateral sclerosis (ALS) is one type of neuromuscular condition. ALS is a progressive neurodegenerative disease that affects the brain and spinal cord, causing motor neurons to deteriorate resulting in the brain losing the ability to initiate and control muscle movements [3]. Patients often lose muscle control in all parts of their body including the arms, legs, neck, mouth, and even diaphragm. In 2015, over 80,000 Americans were diagnosed with ALS [4]. According to the National Institute of Neurological Disorders and Stroke, there is no cure for ALS patients to regain this ability, and many of them require rigid joint support, demonstrating that there is a need for devices to assist with neuromuscular rehabilitation [5].

As a new era of modern neuromuscular rehabilitation emerges, many engineers have been developing technologies that aim to allow people with limited mobility to utilize their joints, as well as boost their strength. Several companies have developed exoskeletons which are wearable robotic devices that integrate human sensing, an actuator, mechanical design, and feedback control that provide extra support to a person’s muscle and enhance physical performance. As ALS results in reduced strength and endurance, activities of daily living (ADLs) are severely affected. Tasks such as holding a book, or reaching for a glass of water can become nearly impossible. One possible solution to improving ADLs is the use of an exosuit to assist joint movement and augment muscular strength.

The two major types of exoskeletons are rigid and soft. The rigid devices are often uncomfortable, defeating their overall purpose of providing ease of life for people suffering from motor disabilities. According to the Wyss Institute, these devices can “impede a wearers’ natural joint movements, thus causing fatigue and exacerbating the very problems they are attempting to fix”, [6] for people with less severe mobility issues. Soft exoskeletons, “exosuit,” have recently emerged in research, presenting an alternative that, “offer[s] the promise of limited mass on the limb, better comfort, and less kinematic restriction from joint misalignment,” and is more practical for human use due to its malleable nature [7]. Among exosuit designs, motor-controlled Bowden cables show promise. The flexible system can conform easily to the user, and mechanical elements such as gearboxes and pulleys can be used to achieve effective forces.

II. LITERATURE REVIEW

The field of exosuits is relatively novel, so there are a limited number of devices available in the market, thus the review of exosuits must come from published research. This

literature review will examine state of the art designs using Bowden cables in various forms of robotics as use of Bowden cables in solely soft designs is extremely limited. While these cables have been used in many designs including bikes and lawnmowers, their use in assistive technology is rather new. In 2006, a research team claimed that the Bowden cable system was a “novel type of actuator” for use in robotics. The article documented the mechanical properties of the system and evaluated it under low load scenarios. The researchers concluded that “the capability is demonstrated to use a Bowden cable actuator for haptic applications in a low load configuration, with good force-feedback performance and contact stability in hard contact situations,” demonstrating the use of Bowden cables proved to be promising [8]. An article describing a rigid rehabilitation robot with seven degrees of freedom (dof) was published in 2021 (Fig.1).

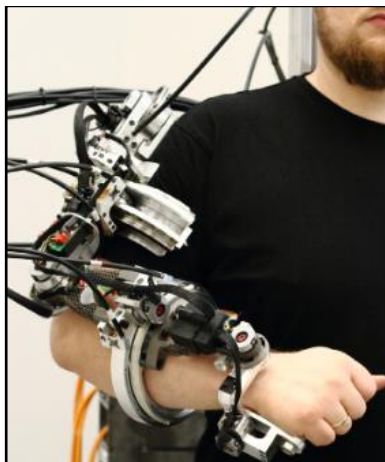

Fig 1. Seven degree of freedom (DOF) exosuit [9]

This Bowden cable actuator device is capable of replicating and assisting human motion using a control algorithm and input from force and torque sensors [9]. The most notable design was from a group at Harvard Biodesign Lab that created a soft lower-limb exosuit able to assist users with walking (Fig. 2).

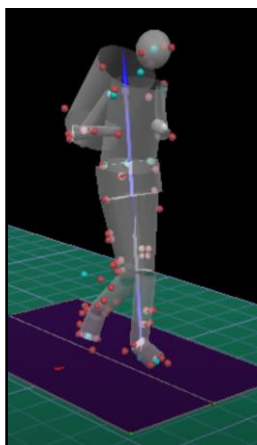

Fig 2. Lower-limb exosuit kinematic analysis [10]



Fig 3. Bowden cable mechanism [10]

Receiving inputs from various sensors such as IMU, and strain gauges, the computer control was able to determine the phase of the user’s gait, and provide the necessary forces on the joints using Bowden cable mechanisms (Fig. 3). Their design is lightweight and portable, providing comfort to the user. It also incorporates passive support which relieves force from the user, even when the actuators are not engaged [10].

Regarding total weight of shoulder-borne apparatuses, a study of 702 elementary school children found that, “it is recommended that backpack weight be limited to no more than 5-10% of the child’s body mass.” Otherwise, the users may begin to feel pain in their shoulders and backs [11].

Based on the literature review, there appears to be a gap in effective, upper extremity, soft exosuits. There are many design difficulties involved in designing a soft exosuit because it is challenging to replicate the kinematics and dynamics of a human musculoskeletal structure. The field of exosuit technologies lacks standards and a unanimous kinematic model for the upper-limb due to the design parameters weighing heavily on the targeted user [12]. Current solutions require the user to be stationary while using the device, or do not target the desired limb. Additionally, many of these devices are expensive or otherwise unobtainable to those who would need it. Overall, the alternative designs all lack accessibility and practicality in some form. Creating a device that is low cost, lightweight, portable, wearable for daily use, and effective at assisting human muscles at low loads will be a significant step for the soft robotics field as well as for patients who need assistance.

The project's goal is to design and produce a wearable upper-limb soft exosuit to help ALS patients maintain their ADLs by achieving at least 130 degree range of motion. Specifically, it will assist elbow flexion and extension and forearm supination and pronation of ALS patients to aid them with raising and lowering their forearms, while lifting small weights such as a glass of water or a book. The exosuit may also be beneficial for users with other neuromuscular disorders. The technical goals include making the device battery powered to allow the user to move freely and fabricating the device with primarily soft components. The two types of actuators that will be explored are a Bowden cable and twisted and coiled polymer actuators (TCPAs). To ensure that the device remains flexible, the use of rigid 3D printed components will be limited. Additionally, in order for the exosuit to be wearable for long periods of time and not cause discomfort, it must weigh less than 5 lbs., assuming that the user is a minimum of 100 lbs. Lastly, the project must

remain under the \$1,000 budget. These specifications are important because there are currently no devices on the market that are lightweight, easily adjustable, and low cost. The creation of this device will ensure that these problems are taken into account, and it will be the first exosuit of its kind available to all people.

III. METHODS AND MATERIALS

A. Hypothesis and Research

The question to answer is, “how can a textile-based soft exosuit be used to maintain activities of daily living in patients with amyotrophic lateral sclerosis?” Because of the novelty of this project, there are very few upper-limb exosuits on the market with similar features. Further research of the topic is needed, especially in a few key areas of power generation, force transmission and speed and accuracy of motion. Finding an optimal source of power that is lightweight and efficient is a major area of interest for this design. A recent study, based on a lower-body Bowden exosuit, showed that a single drive unit could transmit up to 35 Newtons of force in order to assist in the walking motion [13]. These figures are promising, and a drive unit producing similar transmission should have more than enough power to assist with upper-limb motion, as these actions require less force. The power source must also be strong enough and light enough to fit within the aforementioned specifications.

The second part of this question involves finding a drive unit that will not only be untethered, but also have enough battery storage to last a sufficient amount of time. The unit will have to balance power output as well as efficiency so that the user will not be hindered by wires or charging time. There are many battery packs on the market that could power a DC motor with the voltage needed to generate motion, but more research was done to assess the viability of the source. Another recent study showed the promise in upper-limb Bowden exosuit where a 24V DC motor was able to assist with elbow flexion and extension by using the cable as a pulley system [14]. The most important part of this study showed that the overall weight of the exosuit was 800 grams, or about 1.8 pounds. Finally, a design based around a one to two degree of freedom exosuit for elbow and shoulder movement must be made. There are no designs like this on the market currently, so the methods and research for testing this will be truly novel.

B. Methods

There will be a multi-step process in order to design and create this system. First, IMU sensors will be used to track human motion by using Arduino Uno microcontroller boards and MATLAB programming. By connecting IMU sensors to the upper arm and forearm of a human, researchers will be able to collect data from the sensors regarding the orientation and location of the motion. Using this data with Denavit-Hartenberg (DH) convention equations the reference frame can be normalized with each joint on the human model. The DH convention will be calculated using a MATLAB function that relies on inputs of “theta”, “alpha”, “a” and “d”, seen in figure 4 below. When the orientation and position data is captured in MATLAB, the Bowden actuator will then be

programmed in such a manner that only allows movement within the constraints of the captured motion. Finally, two EMG sensors will be placed on the skin of the corresponding muscles so that electric pulses from the muscles can be read and analyzed. The muscle signals in conjunction with the IMU data will be used to tell the actuator when to turn on and off to raise and lower the forearm. This process will accurately and efficiently model human motion for the user.

```
function mat = DH(th, alpha, a, d)
mat = [cos(th) -sin(th)*cos(alpha) sin(th)*sin(alpha) a*cos(th);
      sin(th) cos(th)*cos(alpha) -cos(th)*sin(alpha) a*sin(th);
      0 sin(alpha) cos(alpha) d;
      0 0 0 1];
```

Fig 4. DH Convention Function

To start off calculations, it is assumed that the user has an overall mass of 70 kilograms and height of 168 centimeters. The user's arm was analyzed by looking at it in three parts: the upper arm, forearm, and hand. The assumptions about masses and lengths are as follows, the upper arm will have a mass of 2.1 kilograms and length of 27 centimeters, the forearm will have a mass of 1.05 kilograms and a length of 27 centimeters, and the hand will have a mass of 0.35 kilograms and length of 6 centimeters [15]. It was also desired for the exosuit to assist the user in lifting a 2 kg weight.

Beginning with a Free Body Diagram (FBD), it is found that when the arm is at 90 degrees, the force exerted by the cable must be at least 38.5 N in the y-direction (Fig 5). However, the actual force generated must be equivalent to the force of the cable divided by the sine function of the cable angle. The optimal cable angle for an arm bent at 90 degrees would have a forearm anchor point as far away from the elbow joint as possible to maximize the moment arm, and an upper arm anchor point as close to the shoulder joint, to maximize the angle. This means that the motor will require more power to raise the arm for a smaller cable angle at 90 degrees.

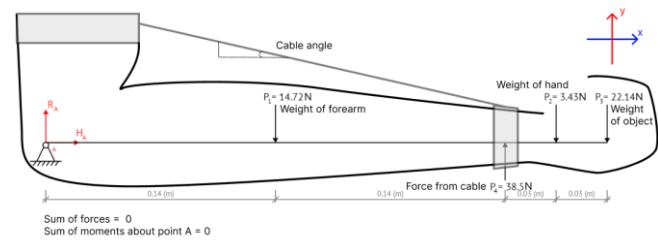

Fig 5. Free Body Diagram (FBD) of the Bowden Cable System resting on the users arm

However, the higher up on the arm the cuff is placed, the more obstructive the cable becomes. To balance these

two parameters, the cuff will be placed 16 cm above the elbow joint. This means that when the arm is at 90 degrees, the cable will form a 29.7 degree angle with the arm, requiring 77.5 N to raise it. Multiplying this value by the length of the arm, 0.27m gives a required torque of 21.0 N-m.

Per the 12 volt DC brushed metal gear motor's data sheet, the maximum power output is 12 Watts, the maximum voltage output is 12 Volts, with no load, the motor rotates at 530 RPM with a current of 200 milliamps, and the stall torque is at 8.5 kg-cm with a current of 5.5 amps. Using the equation below, it is found that the maximum speed the exosuit can operate at is at 5.46 revolutions per minute.

$$Torque (Nm) = \frac{Power (kW)}{Speed (rpm)} \quad (1)$$

In order to achieve this rpm reduction, from the motor's 530 rpm to the design's 5.46 rpm a gearbox will be used. This is a reduction of 97.1:1, but 100:1 will be used instead for the sake of simplicity. The gear train will have three stages: 5:1, 5:1, and 4:1. This equates to gears with teeth, 40:8, 40:8, and 32:8. Using a diametral pitch of 12 in gives a pitch diameter of 3.33 in for the largest gear and 0.667 for the smallest gear. A gear thickness of 0.2 in was used in order to maintain a slim profile in the backpack.

To ensure that the battery is able to last for at least one continuous hour, the maximum battery life was calculated. Using the power equation below it is found that the motor will operate at a current of 1 amp of power. The battery has a lift of 2 amp hours, so it will be able to last for at least 2 hours, assuming that the motor is operating at full power.

$$P = I * V \quad (2)$$

Overall, the exosuit is designed to work optimally for users with bodily proportions similar to the assumed average users. The exosuit's effectiveness will decrease as the user's weight and height increase. User's with significantly smaller proportions will also not experience the full benefit of the device, as the ratio of exosuit weight to user weight will increase.

IV. TECHNICAL DESIGN AND DESIGN ITERATIONS

The novel soft exosuit design assists users through flexion and extension of the elbow joint by means of a single cable actuator spooled around a motor. The cable is driven by a mechatronic motor system, which reads user's muscle signals and positional joint data through EMG and IMU sensors respectively.

A. Initial Design

The initial design consisted of a 12V battery powering a 12V brushed DC motor used in conjunction with a gearbox to increase torque. A Bowden cable would run the length of the user's arm which is secured to the upper arm using a 3D printed nylon cuff over a textile strap (Fig 6). The support on the upper arm is 14.5 cm long by 3.6 cm wide, and is located 16 cm above the elbow joint (Fig 6). It is used to help with consistent Bowden cable actuation and will also hold one IMU sensor. To prevent the strap and cuff from sliding down the arm an inflexible textile anchor strap will connect it to the backpack's shoulder strap. The 3D printed nylon element on the forearm is used to stabilize the second IMU sensor as well as the Bowden cable's anchor point. It is secured to the forearm by textile straps, and has a length of 16.5 cm so as to increase surface area. The Bowden cable anchor point will be 27 cm from the elbow joint. Placement of the exosuit elements may vary slightly by user, but the optimal results will be found when the components are placed similarly to Fig 6.

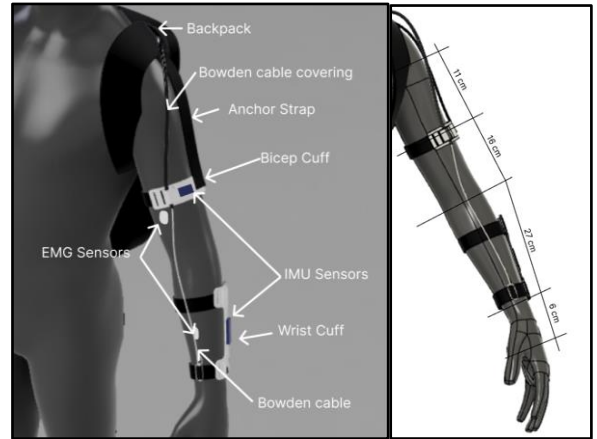

Fig 6. Initial Design displaying backpack, Bowden cable, bicep and wrist cuff, and two EMG and two IMU sensors

The other end of the Bowden cable will be tethered to a 3D printed spool (Fig 7). The spool will be driven by a plastic-encased three stage aluminum gear train which will increase the motor's torque by a factor of 100. The gearbox has a total thickness of 0.7 in (Fig 7). A 12V lithium-ion battery will power the motor. The battery, being the heaviest component of the design, will be located in the backpack closest to the user's torso to maintain a comfortable center of gravity. Additionally, two EMG sensors will be placed on the user to verify the user's intention, one on the inner forearm and the second on the inner bicep. The EMG and IMU sensors and the motor will be wired to the Arduino Uno microcontroller, also housed in the backpack.

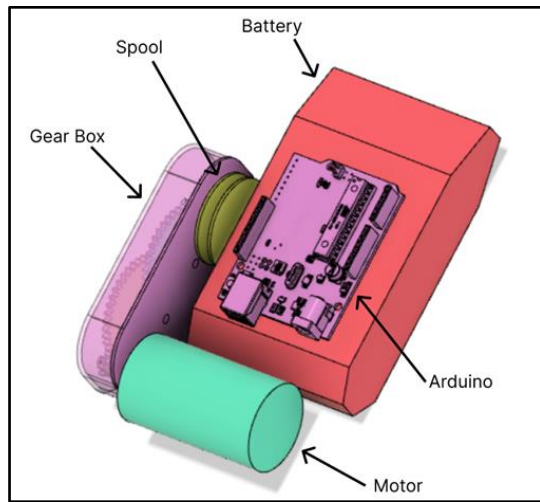

Fig 7. Initial design of components located indeed of the backpack

Due to design goals, the 12V brushed DC motor and gearbox idea was scratched to save space and reduce weight in the backpack. A 24V brushed DC motor with a higher torque was chosen to go with the 24V lithium-ion rechargeable battery. Further testing of the Bowden cable on the spool showed a problem with the large bend radius and small stroke length of the cable. To combat these problems a polyethylene cable was used instead.

B. First Design Iteration

The first exosuit design iteration completed in February did not include either of the EMG or IMU sensors. The components integrated were the Arduino Nano microcontroller, 24V brushed DC motor, motor driver, 24V battery, backpack, polyethylene cable, soft wrist cuff, and 3D printed components such as the shoulder mount, spool, electronics back mount, and motor bracket. The 3D printed designs are shown below in Figures 8 - 11.

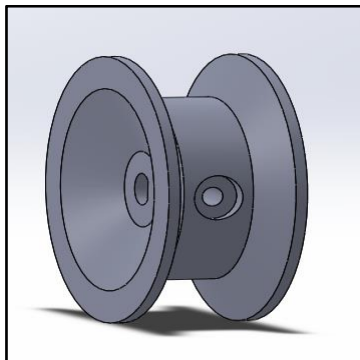

Fig 8. Spool design

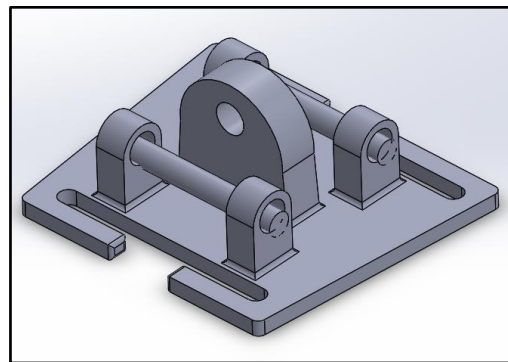

Fig 9. Shoulder mount CAD design

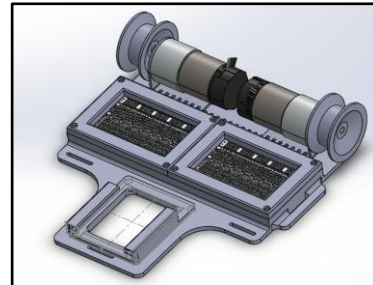

Fig 10. Electronic back mount design

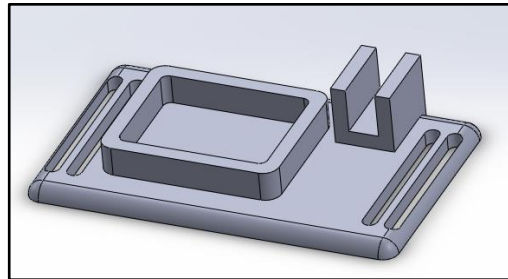

Fig 11. Proposed wrist cuff CAD design for IMU sensor

The electronic back mount design included spots for two motors, two breadboards and a battery. The proposed wrist cuff design held the IMU and one end of the cable. The other end was tethered to the spool which was located in the inside of the backpack and attached to the motor. The motor driver was powered by the 24V battery and connected to the 24V motor and the Arduino Nano. The circuit diagram and photos of the design are shown below in Figures 12-14.

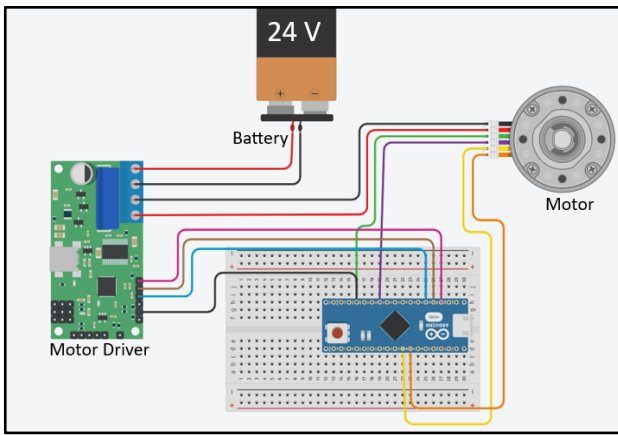

Fig 12. Circuit diagram of the first prototype



Fig 13. First prototype design displaying backpack, cable, shoulder mount, and wrist cuff



Fig 14. View of the inside of the backpack displaying the electronics backboard and its components

The Arduino Nano sent commands to the motor, manually inputting the amount to spin. This determined the angle that users' arms were raised to. Although unable to integrate the sensors, component testing of individual sensors was started at this stage. The first portion of the experiments started by collecting data from the EMG sensor. While the sensor was connected to the Arduino, three group members

were tested to collect data on specific actions that would be beneficial to ALS patients. Each subject ran multiple tests of raising and lowering just the forearm, the forearm holding a water bottle, and the forearm holding a phone in increments of 45 degrees at 10 second intervals. The subjects also raised and lowered their forearm in a constant motion "slowly" and "faster," and flexed their forearm without moving it up and down. These baseline tests were to find preliminary thresholds of the EMG sensor data so that it could be implemented into the motor actuation code. Figures 15-17 show some of the data that was collected from these experiments.

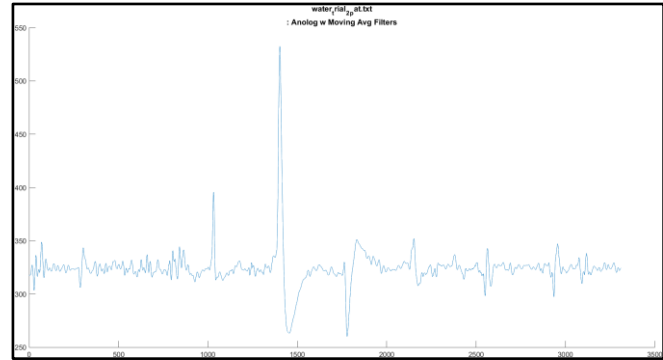

Fig 15. Example of EMG data from lifting and raising a filled water bottle at 45 degree increments at 10 second intervals

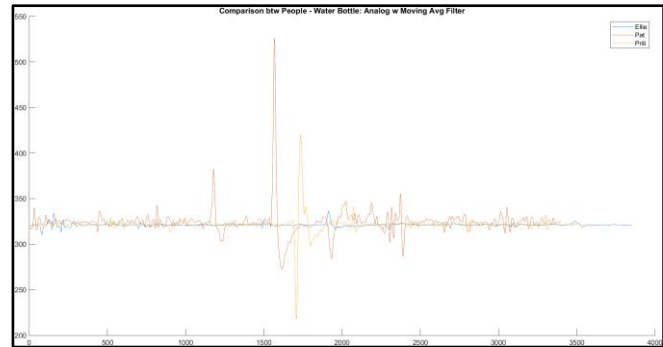

Fig 16. Comparison of EMG data from different subjects lifting a filled water bottle

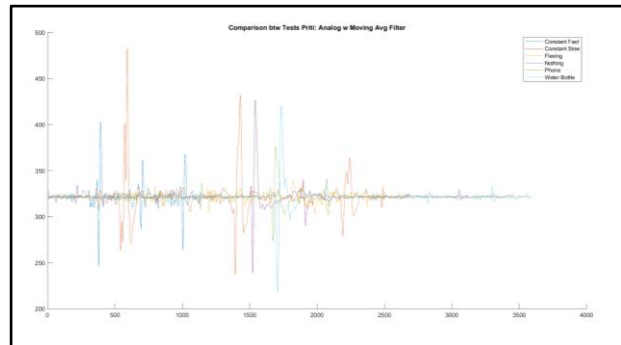

Fig 17. EMG data showing all series of tests conducted to characterize patterns; constant motion fast, constant motion slow, flexing, stop and start motion holding nothing, a phone, and a water bottle

It was found that data for each group member varied greatly as shown by Figure 16, preventing the integration of the EMG at this stage.

C. Second Design Iteration

The second prototype completed at the end of March included many improvements from the first prototype. First, the initial shoulder mount design placed too much stress on the shoulder, causing discomfort, so the design was improved by adding a curve (Fig. 18). Second, 3D printed motor brackets were switched to metal motor brackets ordered off Pololu. The strengthened motor brackets allowed the motor to be tested with heavier objects without breakage.

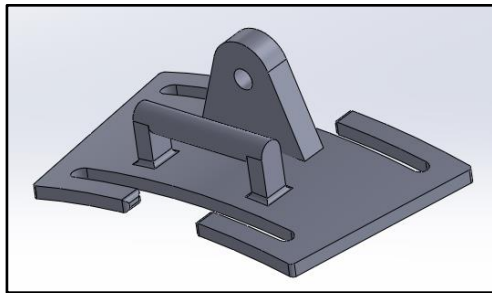

Fig 18. Improved shoulder mount design

To meet one of the initial goals, the design was made fully battery powered by integrating a 24V rechargeable lithium-ion battery into the circuit.

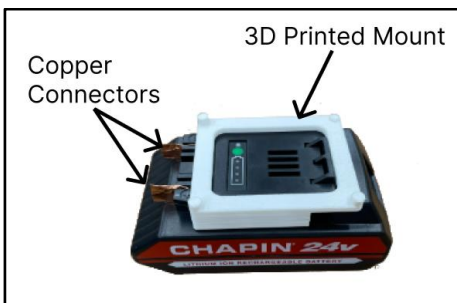

Fig 19. 24 Volt lithium-ion battery shown with 3D printed mount and two copper connectors

At this stage both IMU and EMG sensors were integrated. A calibration period when the Arduino started was added to help with post processing of the EMG data and recognition of muscle activation thresholds. It involved a 5 second period where the subject would rest their forearm relaxed down at their side to get their resting signal, followed by a 10 second period of swinging their forearm up and down through their full range of motion to get their maximum and minimum signal values. The data was then normalized so that the data was zeroed at 0 instead of the varying values from each individual, and maximum and minimum peaks were recalibrated to go from around -1 to 1, which allowed comparison of datasets against each other as seen in Figure 20.

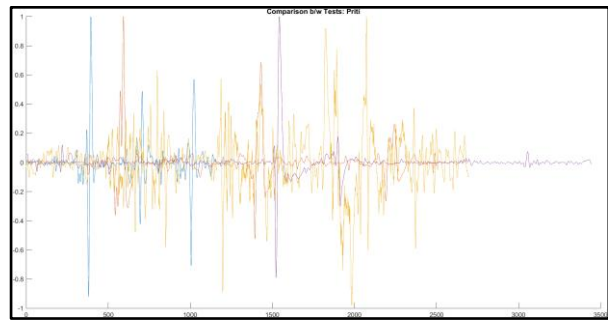

Fig 20. Comparison of EMG signals for different actions normalized at 0 and ranging from -1 to 1 for a single subject

To handle the integration of the sensors, the microcontroller was switched from an Arduino Nano microcontroller to an Arduino Mega. The Mega has more pins, which also allows electronics to be connected together without the use of a breadboard (Fig. 21).

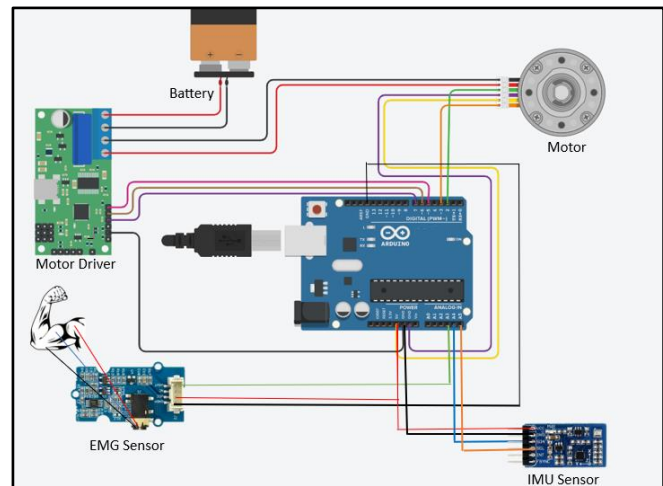

Fig 21. Circuit diagram of second prototype

Integration of the IMU and motor was successful. Based on the position that the IMU read, the motor would change directions.

D. Final Design

The final design includes several improvements from the previous design iterations (Fig. 22). An on/off switch and 9V battery were incorporated to power the Arduino. The on/off switch was added as a safety feature to allow the exosuit to be shut off at any moment in case of an emergency. Furthermore, the switch is located on the user's wrist to allow easy access. The electronics back mount and wrist mount were redesigned to accommodate these changes. The electronics back mount design was adapted to include space for 9V battery, EMG sensor, and the motor driver (Fig. 23). Secondly, the wrist mount was adapted to include space for the on/off switch (Fig. 24). A curve was added to improve the comfortability of the design.



Fig 22. Final exosuit design



Fig 23. Improved electronic back mount CAD design



Fig 24. Improved wrist mount CAD design

The final exosuit design has 3 assemblies: the backpack assembly, wrist assembly, and electronic assembly. The backpack assembly is made from the backpack, shoulder mount, and incompressible tubing. The wrist assembly contains: the soft wrist cuff, wrist mount, IMU sensor, and the on/off switch. The electronics assembly contains: the Arduino Mega, 9V battery, 24V DC brush motor with encoder, spool, polyethylene cable, motor mount, motor driver, 24V rechargeable lithium-ion battery, battery mount, EMG sensor, and the electronics back mount.

The backpack is made of nylon and measures 9"x4"x20". Its main compartment stores the electronic assembly. The PLA 3D printed shoulder mount is located on the top of the right shoulder strap; 3mm padding is used beneath the shoulder mount. An incompressible outer tubing guides the cable actuator from the shoulder mount into the backpack through the access slot (Fig. 25).



Fig 25. Backpack assembly shown with unzipped main compartment. The electronic assembly is housed in the main compartment

The wrist assembly is attached with Velcro to the user's wrist with a soft cuff. The actuator cable is tied to a plastic ring which is stitched onto the soft wrist cuff. The IMU is screwed into the wrist mount and the on/off switch which cuts power to the Arduino Mega is press-fit into the wrist mount. Wires run the length of the arm connecting both the IMU and on/off switch to the Arduino Mega. Adhesive Velcro joins the wrist mount and soft wrist cuff (Fig. 26).

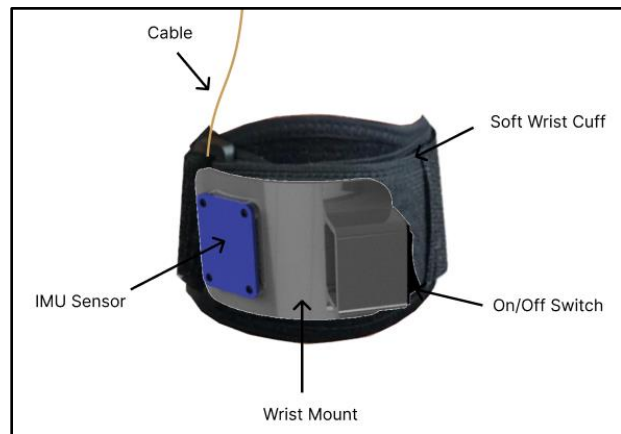

Fig 26. Wrist assembly

The electronic assembly components are mounted on the 0.15" thick, PLA 3D printed electronics back mount with 3mm padding (Fig. 27). The 24V DC motor with encoder is mounted to the top of the electronics back mount with the aluminum motor mount and the spool is attached directly to the motor's shaft with a set screw. The motor is powered by the 24V rechargeable lithium-ion battery, which is attached to the electronics back mount by the PLA 3D printed battery mount. The Arduino Mega microcontroller is powered by the 9V battery. Both the motor driver and EMG sensor

board are screwed onto the electronics back mount. Three wires with electrode sensor pads extend from the EMG sensor, through the access slot, to the user's bicep. The final circuit diagram shows how all the electrical components are wired together (Fig. 28). The entire assembly can be strapped into the backpack using Velcro tabs.

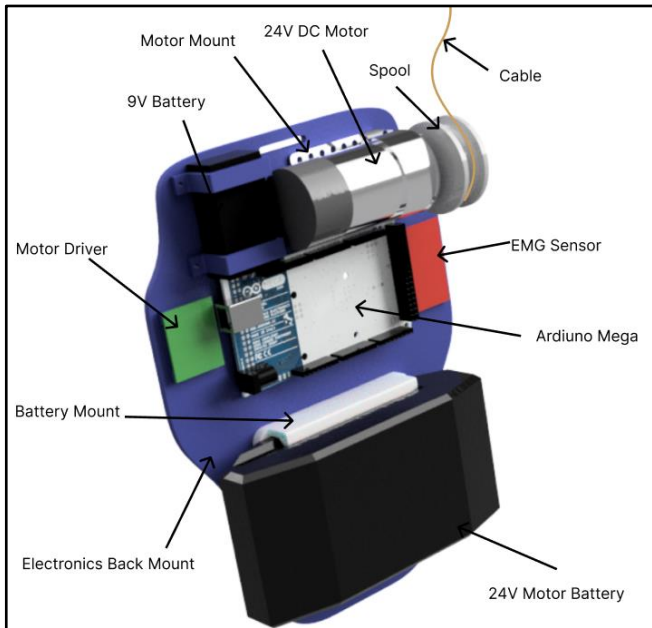

Fig 27. Electronic assembly on back mount

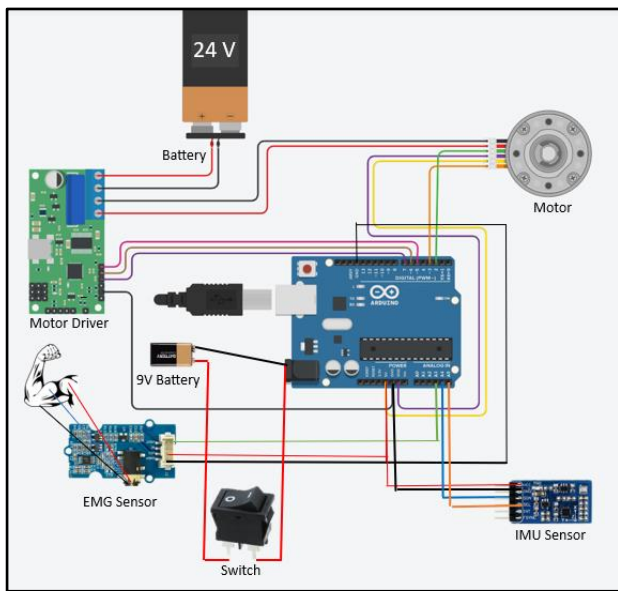

Fig 28. Circuit diagram of the final design

The three assemblies aggregate to form the exosuit. All assemblies are connected in some form by the cable actuator. The wrist assembly is also connected to the electronics assembly by wires. Therefore, the exosuit is one unit, with no discrete components.

In order to activate the motor to wind the cable, the known maximum and minimum threshold of the EMG signal taken during calibration was used to set a target value the subject must output. Due to the very small signals made when lowering the arm, a way to accurately distinguish between lowering the arm versus simply tensing the bicep was not achieved. Thus, the exosuit would raise the user's forearm all the way up when the target signal was reached and lower at the arm once it reached the top. Testing was done, and the user could activate the motor to raise their arm starting down at their side. It can also raise their forearm when it's in the process of lowering if they want to raise their forearm again without having to lower it back down at their side which would help in tasks such as raising and lowering utensils to eat.

V. EXPERIMENTAL RESULTS

Data was collected for 5 different load cases (Table 1). Tests were performed on the elbow joint moving through flexion and extension with various weights. Functionality, current consumption, range of motion were measured. Two trials were recorded for each load case, except the bowling ball which was tested only once due to potential system failure. The total weight of the exosuit was 4.1 lbs, and the estimated cost was \$337.

Table 1: Flexion and extension data with various loads: 160lb user

	No Load (extension)	Only weight of arm (flexion)	1 lb weight (flexion)	5lb weight (flexion)	8lb weight (flexion)
Exosuit deforms	no	no	no	no	yes
Max current (amps)	0.26	0.38	0.43	0.56	0.7
range of motion (degrees)	0-150	0-150	0-150	0-150	0

Results Discussion

The initial design goal was to create an accessible exosuit capable of assisting an ALS patient in the full range of elbow flexion and extension with weights of up to 5 lbs. For the exosuit to be accessible meant wearable for long periods of time: up to 1 hour without discomfort or battery recharge, lightweight: under 5 pounds, and low cost: total material cost under the budget of \$1,000.

The data shows that for weights below 5 lbs., the exosuit was successful in flexing and extending the user's elbow joint through full range of motion. No significant differences, such as actuation time, were found between the loading cases under 5 lbs. However, at 8 lbs., the exosuit deforms and is unable to assist the user. This was found to be a result of the device only weighing 4.1lbs and not providing a high enough counterforce, even with the tightened straps adding friction. A more invasive strapping system or greater backpack weight could generate the larger counterforce needed to raise 8lbs.

The device can be worn comfortably for long periods of time. Multiple users were able to wear the exosuit for over an hour with no sign of discomfort or fatigue. Additionally, one battery charge can last the user at least a day given normal

use. Assuming the user is lifting a 5 lb. object continuously, the 2 amp-hour battery can operate for over 4.5 hours. However, donning and doffing can take time. A typical user can don or doff the exosuit in 2-4 minutes. A patient with ALS may take longer or require assistance depending on their condition.

The total cost of the system was estimated to be \$337, meaning the project was significantly under budget. Many of the parts were purchased for single use and prototyping. A more efficient and streamlined purchasing strategy could reduce costs further.

Overall, the exosuit met the key design goals. The device was found to be functional for weights of up to 5lbs, weighed less than 5 lbs., could be worn continuously, and was under budget. While donning and doffing time was not an explicit project goal, the final donning and doffing method hinders user accessibility.

In light of the results, the exosuit has the potential to help people with neuromuscular disorders complete ADLs, and would be the only soft, upper-limb mechatronic exosuit with EMG sensors available at an affordable price.

VI. DISCUSSION, CONCLUSION, AND FUTURE WORK,

A. Discussion

In the initial planning and design phases, TCPAs and Bowden cable were both considered to achieve actuation. There is limited research for TCPAs. The key problems with the actuators are the inability to contract at sufficient levels as well as the thermal heat that is emitted when actuated. Because of these design challenges, the team had to create a new design based on Bowden cable actuators. In the end, a polyethylene cable was used due to the Bowden cable's large bend radius and small stroke length which was suboptimal. The team also faced challenges with the Arduino Nano microcontrollers. While they were small and cheap, problems uploading and executing code were frequent. Moving to a more powerful microcontroller, the Arduino Mega, greatly improved prototyping efficiency. The most difficult challenge the group overcame was interpreting EMG data for a variety of users. This is where normalization became useful. By normalizing the data between users, the threshold for the signal could be set at a certain percentage of their max EMG signal rather than having to reach a specific number. This guarantees that a user can hit the threshold signal needed to activate the motor.

The novelty in the design is its accessibility. In addition to the low weight and low material cost, a key factor that makes this design stand out from other cable designs is the initiation of actuation by muscle signals through EMG sensors. The user can easily trigger assistance with their muscle intention; no complex controls are required. Furthermore, users can specifically fit the exosuit to their body and calibrate it based on their own muscle signals through the use of the EMG sensors.

B. Conclusion

Neuromuscular disorders like ALS affect many Americans and others across the world. Most affected individuals struggle with ADLs and require a caretaker to complete these tasks. The project's goal to design and produce a wearable upper-limb soft exosuit to help ALS patients maintain their ADLs through elbow flexion and extension and forearm supination and pronation assistance, while lifting small weights such as a glass of water or a book was only partially achieved. The upper-limb soft exosuit was able to achieve the full range of motion of the elbow joint or about 150 degrees. Due to time limitations the addition of a second degree of freedom to assist in forearm supination and pronation was not achieved. The exosuit is fully contained; able to run off a 9 volt and 24V battery to power the Arduino and motor which allows the user to freely walk around. The design also has limited 3D print components and weighs less than 5lbs lending to a comfortable design.

C. Future Work

The main project goal was focused on functionality, but in the future, the scope of the design can be expanded upon. Most important is user safety. Methods could include implementing circuit design to limit motor stalls and high currents. Further advances could increase protection of the electronic components and overall system durability. Improvements can also be made to the actuation control code by running ALS patient EMG signals through machine algorithms for more accurate user intention identification. The exosuit can also be modified to have a second motor and cable for assistance to both arms.

REFERENCES

- [1] Neuromuscular Disorders | MedlinePlus. (2020, January 3). Neuromuscular Disorders | MedlinePlus. Retrieved November 11, 2022, from <https://medlineplus.gov/neuromusculardisorders.html>
- [2] Deenen, J. C., Horlings, C. G., Verschuuren, J. J., Verbeek, A. L., & van Engelen, B. G. (2015). The Epidemiology of Neuromuscular Disorders: A Comprehensive Overview of the Literature. *Journal of neuromuscular diseases*, 2(1), 73–85.
- [3] The ALS Association. (2021, April 26). What is ALS? <https://www.als.org/understanding-als/what-is-als>
- [4] Arthur, K. C., Calvo, A., Price, T. R., Geiger, J. T., Chiò, A., & Traynor, B. J. (2016, August 11). Projected increase in amyotrophic lateral sclerosis from 2015 to 2040. *Nature communications*. Retrieved November 11, 2022, from <https://www.ncbi.nlm.nih.gov/pmc/articles/PMC4987527/>
- [5] National Institute of Neurological Disorders and Stroke. (n.d.). Amyotrophic Lateral Sclerosis (ALS) Fact Sheet. <https://www.ninds.nih.gov/amyotrophic-lateral-sclerosis-als-fact-sheet>
- [6] Wyss Institute. (n.d.). Soft Exosuits for Lower Extremity Mobility. <https://wyss.harvard.edu/technology/soft-exosuits-for-lower-extremity-mobility/>
- [7] Tiboni, M., Borboni, A., Vèrité, F., Bregoli, C., & Amici, C. (2022). Sensors and Actuation Technologies in Exoskeletons: A Review. *MDPI*. <https://doi.org/10.3390/s22030884>
- [8] Schiele, A., Letier, P., van der Linde, R., & van der Helm, F., (2006, October) Bowden Cable Actuator for Force-Feedback Exoskeletons. <https://ieeexplore.ieee.org/document/4058962/>
- [9] Herbin, P., & Pajor, M. (2021, May 11). Human-Robot Cooperative Control System based on serial elastic actuator Bowden Cable Drive in ExoArm 7-DOF upper extremity exoskeleton. *Mechanism and Machine Theory*. Retrieved November 11, 2022, from

<https://www.sciencedirect.com/science/article/pii/S0094114X21001300>

- [10] Soft Exosuits | Harvard Biodesign Lab. (n.d). <https://biodesign.seas.harvard.edu/soft-exosuits>
- [11] Vida, G., (2006). How much load do Saudi school boys carry on their shoulders? Saudi Med Journal.
- [12] Gull, M. A., Bai, S., & Bak, T. (2020). A Review on Design of Upper Limb Exoskeletons. <https://doi.org/10.3390/robotics9010016>
- [13] Li, X., Liu, J., Li, W., Huang, Y., & Zhan, G. (2022). Force Transmission Analysis and Optimization of Bowden Cable on Body in a Flexible Exoskeleton. *Applied bionics and biomechanics*, 2022, 5552166.
- [14] Wei, Wei & Qu, Zhicheng & Wang, Wei & Zhang, Pengcheng & Hao, Fuchun. (2018). Design on the Bowden Cable-Driven Upper Limb Soft Exoskeleton. *Applied Bionics and Biomechanics*. 2018.
- [15] Plagenhoef, S., Evans, F.G., & Abdelnour, T. (1983) Anatomical data for analyzing human motion. *Research Quarterly for Exercise and Sport* 54, 169-178.
- [16] Bostelman, R., & Hong, T. (n.d.). *Test Methods for Exoskeletons – Lessons Learned from Industrial and Response Robotics*. https://tsapps.nist.gov/publication/get_pdf.cfm?pub_id=922383