

# **Co-Navigational Aquaculture Vehicle System Design**

A Technical Report submitted to the Department of Mechanical and Aerospace Engineering

Presented to the Faculty of the School of Engineering and Applied Science  
University of Virginia • Charlottesville, Virginia

In Partial Fulfillment of the Requirements for the Degree  
Bachelor of Science, School of Engineering

**Charles Tilney-Volk**

Spring, 2023

Technical Project Team Members

Alvaro Crisanto

Brian Richard

Peter Stauffer

Kristen Babel

On my honor as a University Student, I have neither given nor received unauthorized aid on this assignment as defined by the Honor Guidelines for Thesis-Related Assignments

Tomonari Furukawa, Department of Mechanical and Aerospace Engineering



In Conjunction with the University's  
**Virginia Cooperative Autonomous Robotics (VICTOR) Lab**  
directed by Dr. Tomonari Furukawa



SCHOOL *of* ENGINEERING  
& APPLIED SCIENCE  
Department of Mechanical and  
Aerospace Engineering



# Table of Contents

<b>1</b>	<b>Introduction.....</b>	<b>4</b>
1.1	Importance of Work.....	4
1.2	Previous Work.....	4
1.3	Connecting Previous Work.....	5
1.4	Objective.....	6
1.5	Outline.....	6
<b>2</b>	<b>Essential Knowledge.....</b>	<b>6</b>
<b>3</b>	<b>Design Process.....</b>	<b>7</b>
3.1	Customer Needs.....	7
3.2	Target Specifications.....	9
3.3	Concept Generation.....	10
3.4	Concept Selection.....	12
<b>4</b>	<b>Final Design.....</b>	<b>13</b>
4.1	Overview.....	14
4.2	Computer-Aided Design (CAD) Models.....	17
<b>5</b>	<b>Validation.....</b>	<b>20</b>
5.1	Component Level.....	20
5.2	System Level.....	27
<b>6</b>	<b>Operations Manual.....</b>	<b>29</b>
6.1	ASV Operation.....	29
	ASV Operation Required Equipment:.....	29
	ASV Set-Up and Operation:.....	30
	ASV Maintenance and Disassembly:.....	37
6.2	AROV Operation.....	40
	AROV Operation Required Equipment:.....	40
	Cleaning System Set-Up and Operation:.....	40
6.3	Troubleshooting.....	42
<b>7</b>	<b>Conclusions and Future Work.....</b>	<b>43</b>
7.1	Summary.....	43
7.2	Future Work.....	43
	<b>References.....</b>	<b>45</b>
	<b>Appendices.....</b>	<b>46</b>
	Appendix A: Finalized Schematic of Project Design Process.....	46
	Appendix B: Additional Photos of the Cooling System.....	47
	Appendix C: Concept Screening Outcomes.....	48
	Appendix D: Concept scoring outcomes.....	49
	Appendix E: Mass Flow Rate Analysis of the Cooling System.....	50

# **1 Introduction**

As the world's population continues to grow, it is becoming increasingly important to develop sustainable food production systems. Food demand is expected to increase anywhere from 59% to 98% within the next 30 years (Elferink & Schierhorn, 2016). Aquaculture provides one method that is increasingly important for the future of food production. Aquaculture is the practice of producing aquatic food such as fish, shellfish, and kelp for human consumption and is a practice that has been around for centuries. The practice of aquaculture has advantages over traditional agriculture, as it reduces the amount of water and land needed for production. However, aquaculture has been criticized for its pollution and impact on surrounding ecosystems. These limitations need to be addressed in order to maximize the benefits aquaculture can provide.

Offshore aquaculture is seen as one solution. Compared to coastal aquaculture, Offshore aquaculture can achieve larger scale, and moves the operation away from sensitive coastal ecosystems (FAO, 2022). The location and conditions of these facilities is a challenge. Offshore operations of any kind require specially trained staff, and costly transportation of personnel and supplies.

## **1.1 Importance of Work**

Cleaning aquaculture fish pens is a necessary part of aquaculture and is vital to a healthy fish population. Unfortunately, cleaning these fish pens can be a hazardous and time consuming job for humans. The fish pens are currently maintained through a combination of remotely operated vehicles (ROVs) and trained divers. The conditions and cost of transportation makes offshore facilities a prime venue for autonomous robotics, which can be deployed to carry out a variety of tasks related to cleaning fish pens, such as scraping away algae, removing debris, and removing dead fish. By using autonomous robots, human workers can stay out of harm's way while the robot carries out its tasks. In addition to reducing the risk to human workers, autonomous robots can also help improve the efficiency thus saving money on labor costs. This increased return on investment demonstrates that autonomous robots are an economically viable product.

## **1.2 Previous Work**

As stated, fish pen maintenance has been performed by one of two main methods. The first is manual clean by divers. This is the most costly method available and divers require special training, and hazard pay. This method is also difficult to scale up to large facilities (ADAS, 2022). The second method is the use of an ROV. Most require an operator on the surface to navigate the system. An example of such systems would be the Mainstay RM3 (Mainstay, 2022). In addition to requiring a human operator at all times, these systems also require

significant power supplies. For offshore aquaculture facilities, this usually means power generated by diesel generators. The fuel for which needs to be transported out to the facilities. At least one product is available that does not require remote navigation, which is the Remora by Remora Robotics. The Remora self navigates along the net cleaning as it goes (Remora Robotics, n.d.). Its weakness is that it cannot move itself between pens. This means operators need to have one for each pen, or they need to manually move it between pens.

Early work on AUVs focused on the development of basic underwater vehicles capable of simple tasks such as mapping the ocean floor or taking measurements of ocean parameters. Over time, advances in technology have enabled the development of more sophisticated AUVs capable of performing complex missions, such as underwater exploration, inspection, and surveillance. These machines are increasingly being used to monitor underwater fish pens, which are used to grow and harvest fish in the ocean. These pens are often located in open water, where they are subject to environmental factors such as water currents, temperature changes, and weather conditions, which can affect the health of the fish and the overall productivity of the pen.

AUVs equipped with sensors can be used to monitor these environmental conditions and provide real-time data to fish farmers. For example, AUVs can measure water quality parameters such as dissolved oxygen, pH levels, and temperature, which are critical for maintaining the health of the fish. They can also detect any changes in water currents, which can help farmers adjust the location of the pens to optimize the flow of water and ensure that the fish are getting enough oxygen and nutrients. In addition to environmental monitoring, AUVs can also be used to monitor the fish themselves. For example, they can be equipped with cameras and acoustic sensors to track the behavior and movement of the fish, which can provide valuable insights into their health and wellbeing. AUVs can also be used to detect any signs of disease or parasites that may be affecting the fish, which can help farmers take corrective actions before the problem spreads. Ideally an autonomous system would be able to service all pens without human intervention.

### **1.3 Connecting Previous Work**

In order to improve upon the methods already in place, our system will need to rely on novel techniques. Research in the realm of autonomous marine vehicles will support our efforts developing our system. One avenue of research involves the harnessing of wave energy to power autonomous vehicles. This approach is being explored at the University of California, Berkeley. They developed a mobile Wave Energy Converter (WEC) and an autonomous underwater vehicle (AUV) that could dock with the WEC vehicle and charge its batteries (Sun, 2021). This system transfers power to the AUV using an induction charging method. It also has limited data transfer among vehicles, relying on radio transmission. An alternative to both these aspects is to use a tether for power and data transfer between vehicles. Research into tethered systems has also been conducted and can support our goals. Research at the University of California San Diego focuses on tethered aerial vehicles and includes the use of a ‘smart spool’ to control the

amount of slack needed in a tether (Talke, Birchmore, Bewley 2022). The spooling of a tether would be an important system to a tethered co-robotic system. Since the research conducted so far has focused on aerial vehicles, it needs to be extrapolated to underwater vehicles. Research into co-robotic systems can also support our goals, such as the work at Dalhousie University which aims to explore the mapping capability of multiple different robots working together to map partially submerged targets. Each robot in the system operates in a different environment and uses different sensors. This allows them to create a more comprehensive map of a target than either could on their own (Lindsey, 2022). This research only pertains to sensing and thus has limited application to the current goals of the project. Research and work done by Virginia Tech also were also looked at. Although their work was more focused on the wave energy converter, they constructed a surface vehicle that could be navigated remotely. However, a possible evolution of the system could involve the collection of vast amounts of data on the condition of nets and fish. This data could help operators fine tune and optimize their facility.

## **1.4 Objective**

Our objective is to develop surface and underwater vehicles to support the maintenance of offshore aquaculture facilities. The system will initially be programmed for remote operation, which will permit ease of transition into a fully automated system, and ensure that testing of the design can be done more easily before advancing to a more complex programming environment. These two options – remote and autonomous – allow for a reduction in the safety hazards posed to those who work on these growing aquaculture farms. Additionally, the capability of the underwater vehicle to clean fish nets on its own will remove the safety risk associated with diving to clean these pens entirely.

## **1.5 Outline**

This report will cover all background information needed to understand the ideas behind our design. It will also include the process followed in order to produce the design: customer needs, target specifications, concept generation, and concept selection. The report will conclude with a look at our finalized designs and progress made on them.

## **2 Essential Knowledge**

The general design of the ASV drew inspiration from other university teams' recent designs. We gathered aspects of each surface vehicle that we thought were useful, and attempted to combine them into one and create a durable, buoyant, efficient, and simple system.

Developing a remote operation (or tele-op) control system is an important step in the process of developing autonomous operation. While the BlueROV2 was designed as a commercially available remotely operated vehicle, the surface vehicle (ASV) was designed and

fabricated by the team. The first steps to combining these two into one co-robotic system was to understand the software environment they are built for, namely BlueOS, QGroundControl and ArduSub.

Understanding how QGroundControl/ArduSub and BlueOS work together is necessary in order to understand how the surface vehicle system became remotely operated. BlueOS was an operating system developed by BlueRobotics that serves to simplify the human-machine interface and make remote operation more straightforward. Within its packages, it includes QGroundControl and ArduSub. QGroundControl serves as the user interface, allowing us to visualize the vehicle's perspective, as well as monitor all sensors, location pings, and remote control inputs in real-time. Working alongside this is ArduSub, which is the autopilot software that processes the input from the remote controller and interprets the vehicle's motion. The two together are what enabled us to remotely operate our own device. The hardware that these systems will run on will be the same hardware needed for a ROS centered control system. This allows the project to proceed to ROS development and automation without any critical hardware modifications.

Additionally, we must address the characteristics of an effective cleaning mechanism. The system will be attached to the underwater vehicle – so it must be capable of handling underwater conditions for long periods of time. Furthermore, the selected mechanism should not damage the fish nets used in the aquaculture pens.

### **3 Design Process**

The design process consists of the following steps: identification of customer needs, drawing target specifications from those needs, and then developing design concepts. Finally, the concepts are screened, ranked, and selected. Iterations of these processes are necessary to produce the best outcomes, and to figure out what works for our system and what does not.

#### **3.1 Customer Needs**

The first step in the design process was an assessment of customer needs. This was done by first determining our product, and then drawing out who our markets and stakeholders would be by following the mission statement shown in Table I.

<b>Product Description</b>	<ul style="list-style-type: none"> <li>Autonomous underwater vehicle with ability to clean aquaculture fish pens.</li> </ul>
<b>Benefits Proposition</b>	<ul style="list-style-type: none"> <li>Decreases need for physical labor, that is oftentimes dangerous</li> </ul>
<b>Key Business Goals</b>	<ul style="list-style-type: none"> <li>Implementation by aquaculture industry</li> <li>Sustainability</li> <li>Decrease the need for trained divers for fish pen maintenance</li> <li>Proof of Concept</li> </ul>
<b>Primary Market</b>	<ul style="list-style-type: none"> <li>Offshore / Open Ocean Aquaculture Facility Operators</li> </ul>
<b>Secondary Markets</b>	<ul style="list-style-type: none"> <li>Coastal aquaculture farming operators</li> <li>Offshore Infrastructure Maintenance/Inspection</li> <li>Other independent institutions performing AUV and ASV research</li> </ul>
<b>Assumptions</b>	<ul style="list-style-type: none"> <li>Rechargeable through off-grid power generation</li> <li>Continuous autonomous operation</li> <li>Efficient</li> <li>Durable</li> </ul>
<b>Stakeholders</b>	<ul style="list-style-type: none"> <li>US government (Navy, Department of Agriculture)</li> <li>Users (farm employees)</li> <li>Additional marine industries</li> </ul>

**Table I:** Autonomous Aquaculture Robot Mission Statement

Gaining customer perspective was crucial in order to determine proper product requirements and specifications. To execute this, the following groups were interviewed or surveyed: Professor Tomonari Furukawa, teaching assistant Julia Rudy, and graduate students at Stevens University with a similar project focus. They were asked the following questions:

1. What are current challenges faced with the cleaning of aquaculture fish pens?
2. What is the greatest challenge you foresee in the development of an underwater autonomous robot?
3. What size or dimensions do you see to be reasonable and feasible for this project?
4. What is the ideal level of autonomy for navigation?
5. What is the ideal level of autonomy for cleaning?
6. What would be the minimum acceptable operational lifetime of the system?
7. What budget do you believe is necessary for this project?
8. What is the minimum acceptable time of operation between charging sessions?

Utilizing the responses of these prompts, which included ideas of what our goals should be and what specifications were important to our design, we then defined our customer needs which were determined to be:

- ASV/AROV should be light and small enough so that one person can carry and transport them to an experimental site.
- The design of ASV should be motor controlled and resemble the system Virginia Tech developed, but on a **smaller scale**.



- The mechanical/electrical design of ASV should be simple so that the system is **stable** and **reliable** in an **offshore and underwater environment**.
- The ASV should have a minimum operational lifetime of **2-5 hours** (i.e. long enough to clean one fish pen).
- The ASV/AROV should be able to efficiently move together via sensor capabilities from one fish pen to another when the AROV is not actively cleaning.
- The AROV and ASV should be **independent systems**, with **no human intervention** needed during fish pen cleaning.

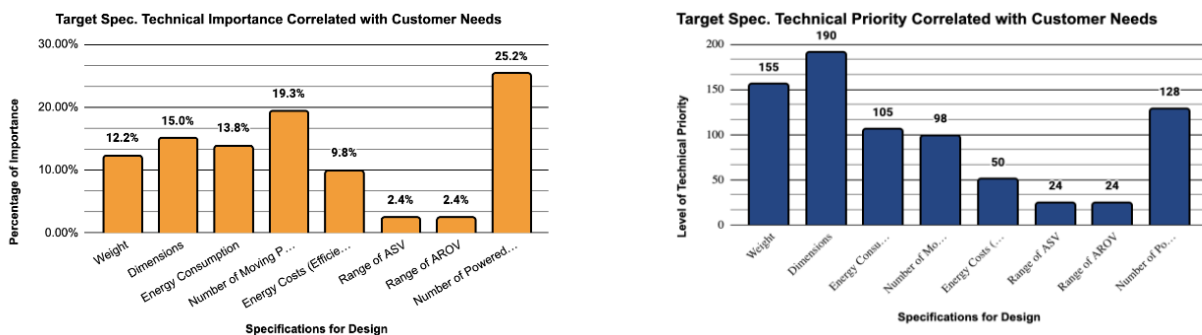
The bolding above highlights the feedback we received from the surveys, and how they were incorporated into the refinement of our customer needs definitions. The next step in the process was extracting target specifications from these customer needs.

### 3.2 Target Specifications

To draw target specifications from the customer needs, we tried to determine a measurable variable from each need and then determine whether it should be maximized or minimized. The targets were decided to be:

1. Minimize → Weight, dimension (length, width, height)
2. Minimize → Power requirements
3. Minimize → No. of moving parts, no. of powered components
4. Minimize → Transportation costs (energy consumption per distance traveled)
5. Maximize → Operational range of ASV and AROV

These were then used in a quality function deployment (QFD), which helped us analyze the specifications to help determine the highest priority and highest importance. The graphs produced by this analysis are shown in Figure 1.



**Figure 1:** Graphs for technical importance and technical priority resulting from the quality function deployment analyses.

Based upon our QFD, we concluded that the greatest components of importance would be related to the number of powered and moving parts. From this, we gathered that our design must be simple in order for it to be successful in its initial stages. If overcomplicated, it could be difficult to pinpoint its weaknesses and figure out what must be improved. Additionally, technical priority was determined to be weight and dimension related. The importance of having a compact and light device is that it will slim down transportation costs, ensure ease of use by only requiring one individual to transport the system, and help reduce energetic losses due to drag.

### 3.3 Concept Generation

Concept generation was used to take into account the target specifications and product goals identified in the previous two processes. There are two components to concept generation: functional decomposition and morphological analysis. Both processes were done for the ASV and AROV to ensure that specifics in regard to their design could be determined.

Functional decomposition involves defining the inputs and outputs of the system, as well as determining all of the device’s in-between processes. In doing so, it becomes easier to create the morphological analysis, which consists of all the device’s sub-functions and possible solutions to them shown in Tables II and III.

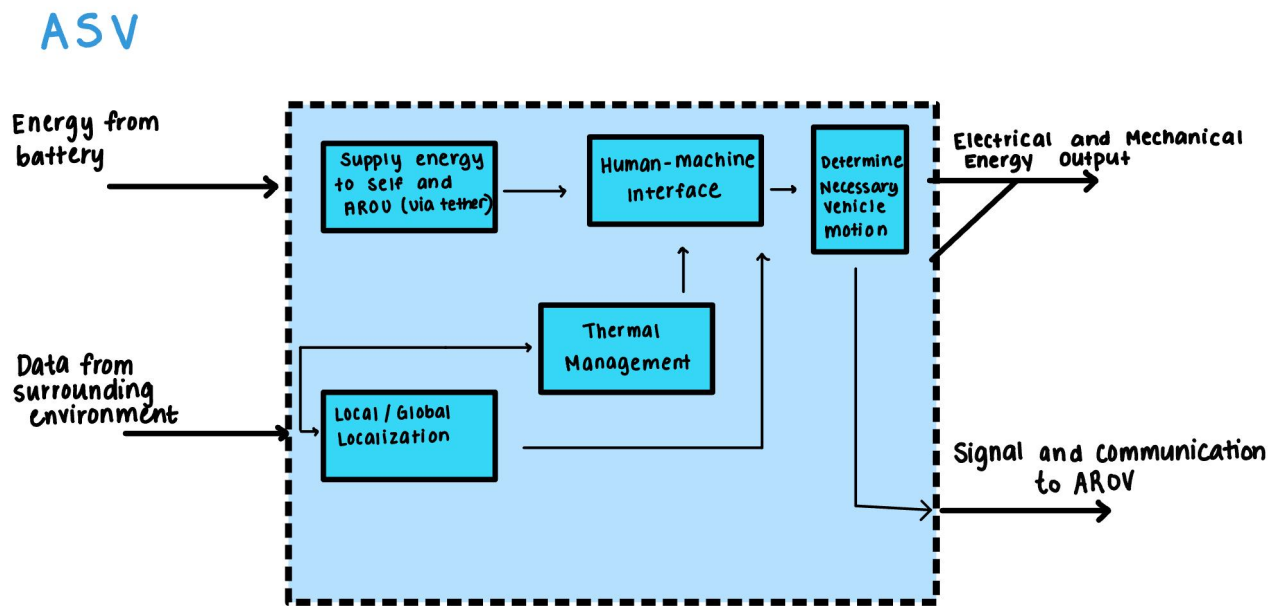


Figure 2: Functional decomposition of the surface vehicle.

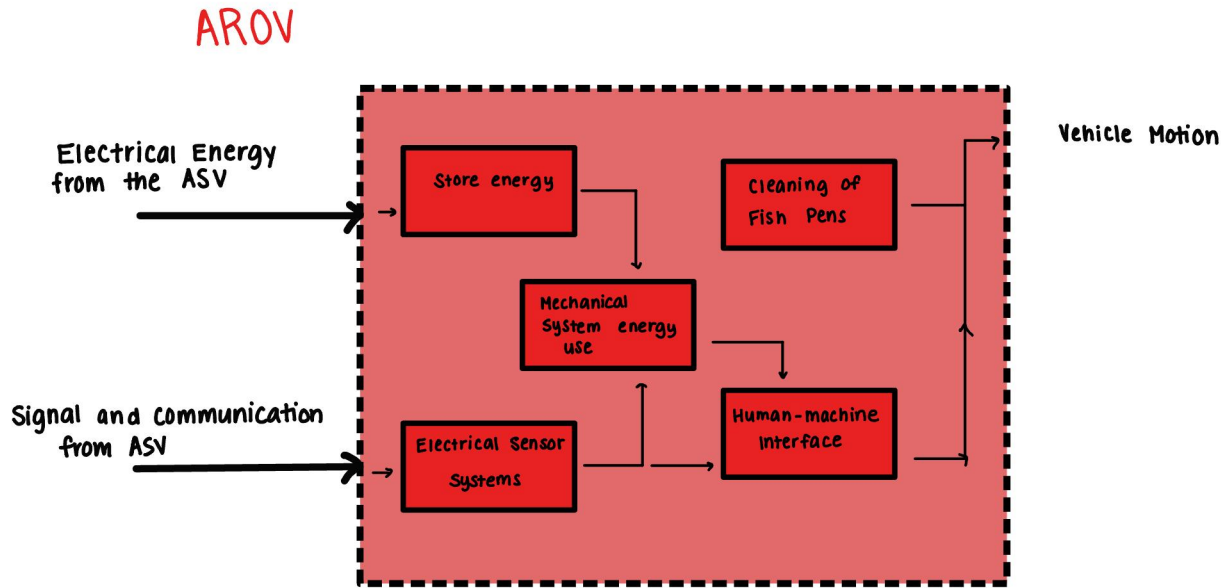


Figure 3: Functional decomposition of the underwater vehicle.

Sub Functions	Solutions				
Store/Accept Electrical Energy	Battery	Capacitor			
Provide Energy to AROV	Continuous Power Supply through Tether	Tether does not supply power; recharge through AROV docking			
Local Localization and Mapping Sensor Systems	Camera systems	LIDAR	Acoustic Sensors	Pressure Sensor	Internal Compass
Global Localization Sensor Systems	GPS				
Thermal Management	Pump + enclosed mass of water (interior system)	Pump + water circulation from ocean (exterior system)	Natural convection with air inlets and outlets	Cooling blocks (on interior and exterior)	
Human-Machine Interface	QGroundControl	Remote Controller	ROS		
Determine & Execute Necessary Vehicle Motion	Open propeller system (with rudders/control surfaces)	Closed thrusters system (multiple)	Variable-buoyancy system		

Table II: Morphological analysis of the ASV system.

Sub Functions	Solutions			
Accept Energy	Tether for continuous power	Recharging docking system with drogue on ASV		
Store Energy	Onboard Battery	Capacitor	Battery Housed in ASV	
Mechanical System Energy Use	COTS configured thruster system (T200)			
Electrical Sensor Systems	SONAR	Internal Compass	Pressure Sensor	Acoustic Sensor
Human-Machine Interface	QGroundControl	Remote Controller		
Cleaning of Fish Pens	Robotic Pinchers	Nets	Water Jet + Pump Mechanism	

**Table III:** Morphological analysis of the AROV system.

The solutions highlighted in red indicate our chosen approach, which was determined to be the best design plan by our concept screening and scoring processes.

### 3.4 Concept Selection

To select our final concepts, concept screening and scoring processes were used with two different rating scales. For concept screening, selection criteria were rated versus the different potential solutions. If the solution fit that criteria well, it received a '+'. If the solution fit the criteria poorly, it received a '-'. A zero was received if the solution was a neutral fit. The sum of each sign was totaled at the end to give each potential solution a net score and ranking. A '+' increased the score by one, and a '-' decreased the score by one. This score numerically ranked the concepts and determined whether or not that solution should move onto the concept scoring process.

A more quantitative approach for choosing each specific subsystem on the vehicle was necessary before purchasing products and developing a preliminary design. Using a concept scoring analysis, also known as a trade study, each subsystem was judged using a particular set of weighted criteria and was scored on how well that particular system met each of the criteria's requirements. The scores were provided from 1 to 5 – these numbers represent the worst performing and best performing for the given criteria, respectively. The weighing of the criteria was then multiplied by the score of the particular system and then repeated for each criteria. The

summation of these products would provide a total score of each system, and the system with the highest total score yielded the most desirable system to pursue. The importance of concept scoring is that it provides a quantifiable, less-subjective, and observable justification for the chosen design of the system. This is useful as it can be presented professionally and re-analyzed when unexpected problems occur in the design process.

For our systems, it was not necessary to perform a concept screening and scoring for concepts with clear and obvious solutions, such as using (1) a tether for energy transfer, (2) a battery energy storage, and (3) QGroundControl/ArduSub as the robotics middleware. On the other hand, the completed concept screening/scoring focused on the following vehicle categories:

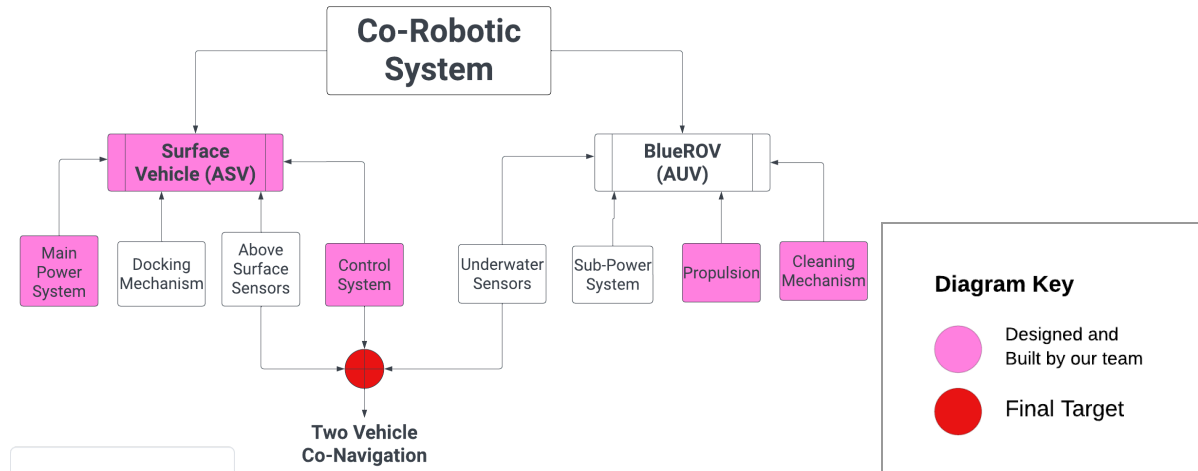
1. Control Software
2. Cleaning Mechanisms
3. Cooling System structure and coolant

It was insufficient to group all of the listed categories into a single selection process. The full concept screening and scoring processes can be viewed in Appendices A and B for each function. The findings of these processes resulted in the following solutions being ranked as the top choice. The incorporation of these solutions is shown in the following section.

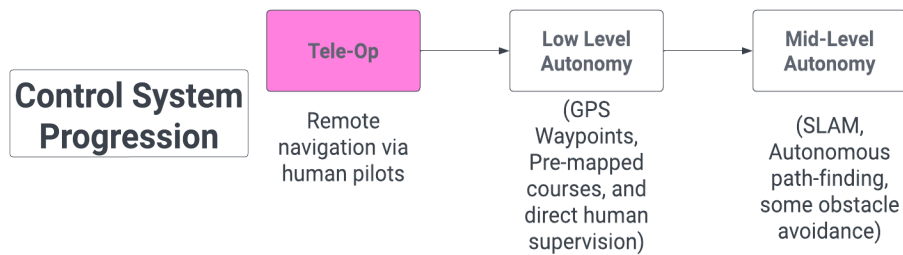
1. Control Software: QGroundControl
2. Cleaning Mechanism: Water Jets
3. Cooling System
  - a. Water Cooled
  - b. Closed System

## **4 Final Design**

The diagram below illustrates the many different components to this project, as well as which components our team plans to cover in the following sections. The design of the surface vehicle was a large part of our focus, in addition to the cleaning mechanism designed for the underwater vehicle provided to us.



**Figure 4:** Broad overview of project goals and design plan.



**Figure 5:** Breakdown of the predicted control system progress, illustrating our team’s progress.

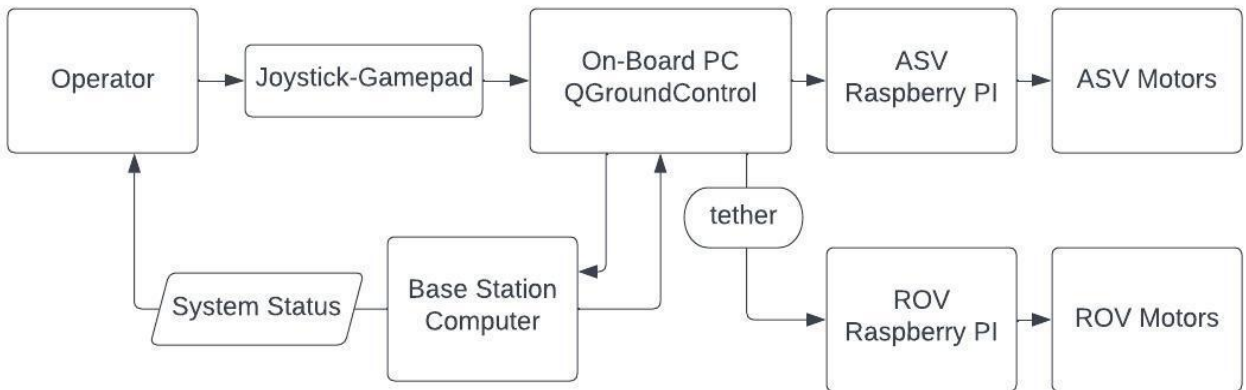
## 4.1 Overview

The ASV design is built on a catamaran style hull with a central housing for control systems and electronics. The housing includes a cooling system to manage heat from the electronic components. The vehicle is propelled by two submerged thrusters, and uses differential steering for navigation. The control system is a combination of a base station computer (outside the vehicle), on-board computer (ASUS MiniPC), and Raspberry Pi 4. The ASUS runs the control software, QGroundControl, the base station is linked to the onboard PC through Windows Remote Desktop and Xrdp. The base computer relays system status and other information to the operator. The Raspberry Pi interprets commands from the on-board computer and controls the motors. A full outline of the system architecture is in the appendix.

The AROV is built on the commercially available BlueROV2. The existing vehicle structure and electronics will support the addition of a water jet cleaning system. The BlueROV2 comes with an on-board Raspberry Pi that receives commands from the tethered computer. The Pi operates the six thrusters to control position.



**Figure 6:** Full overview of the ASV and BlueROV2 system.

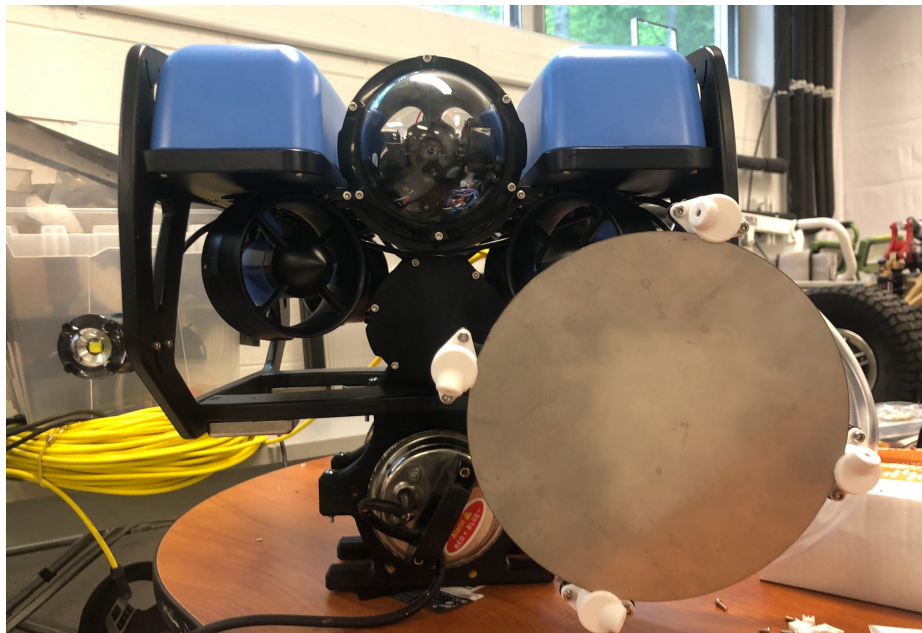


**Figure 7:** Overview of the software systems utilized to remotely operate the surface and underwater vehicles simultaneously.



**Figure 8:** ASV remotely operated in a lake environment.

The basis of the cleaning mechanism is a rotating circular disk made of stainless steel 304 with a 7 inch diameter and 0.125 inch thickness. The rotation is powered by four nozzles attached to the disk and ejecting water. This water is supplied by a submersible pump that runs on 12V direct current. It travels through a 1 inch diameter tubing, through a rotary union, and the cross-tee joint shown in red. The joint is responsible for distributing the water evenly throughout all four nozzles.



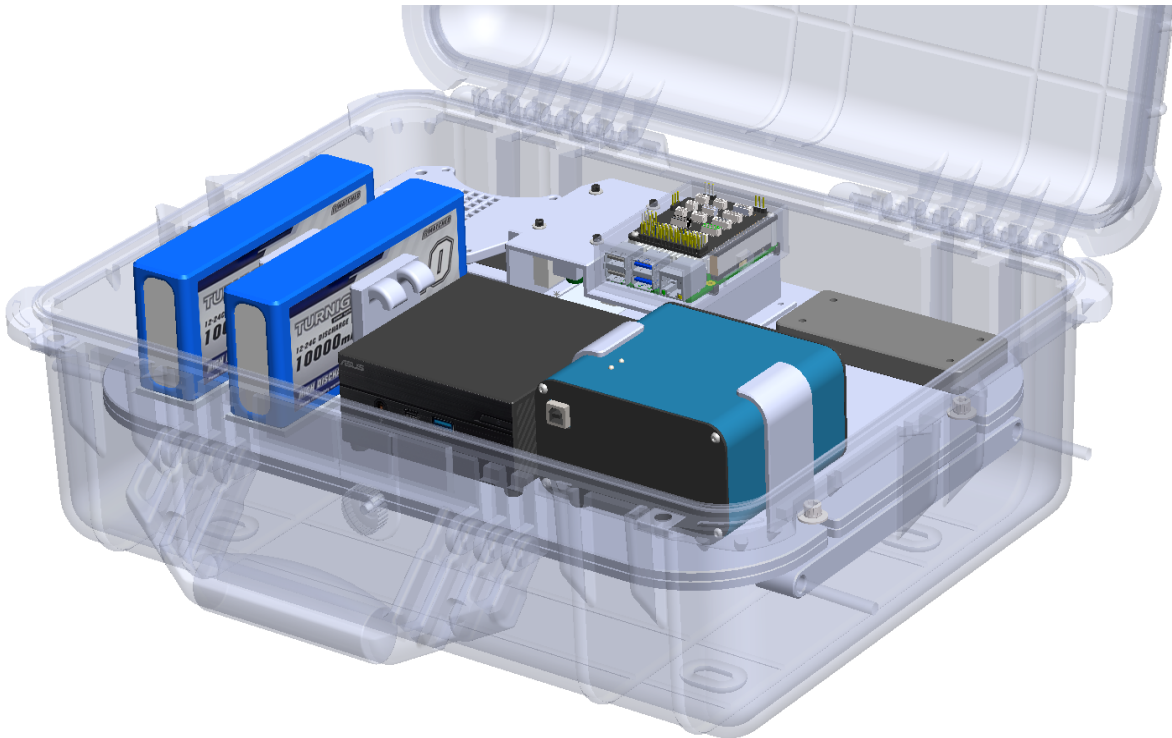
**Figure 9:** ROV Cleaning System.



## 4.2 Computer-Aided Design (CAD) Models

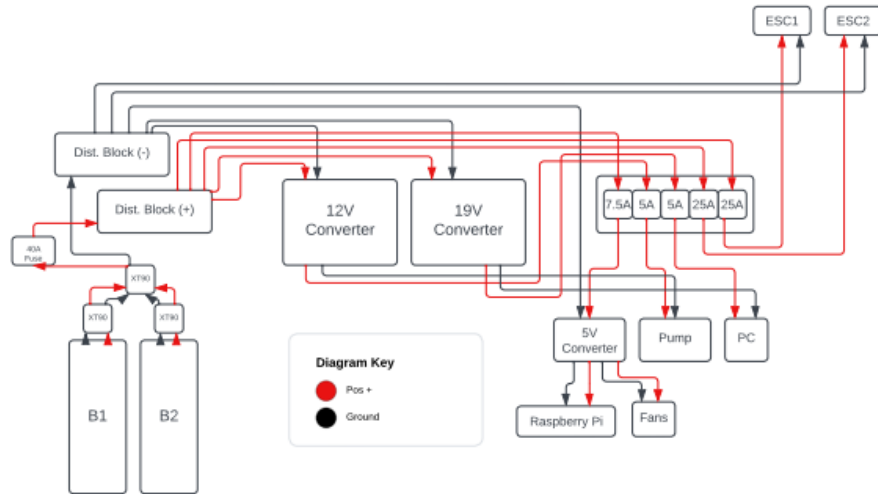
Three Solidworks assemblies will be discussed in this section. One assembly will illustrate the plans for the interior of the surface vehicle, which was recently fabricated and are shown in the latest progress section of this paper. The second assembly will illustrate the chassis of the surface vehicle and the final assembly will demonstrate the final design of the cleaning mechanism.

The first CAD model shown in Figure 9 illustrates the general layout of the electrical components. This layout is optimal because it organizes the power sources and its relevant components (distribution terminal, power converters, and fuse block) consecutively, then allows the output to go directly to its proper component, like the PC. Prior to the 3D printed layouts for the interior, a wooden plank was utilized to guide the CAD planning and help visualize the location of each component. The figure afterwards illustrates the electrical diagram associated with the layout shown in figure 9.



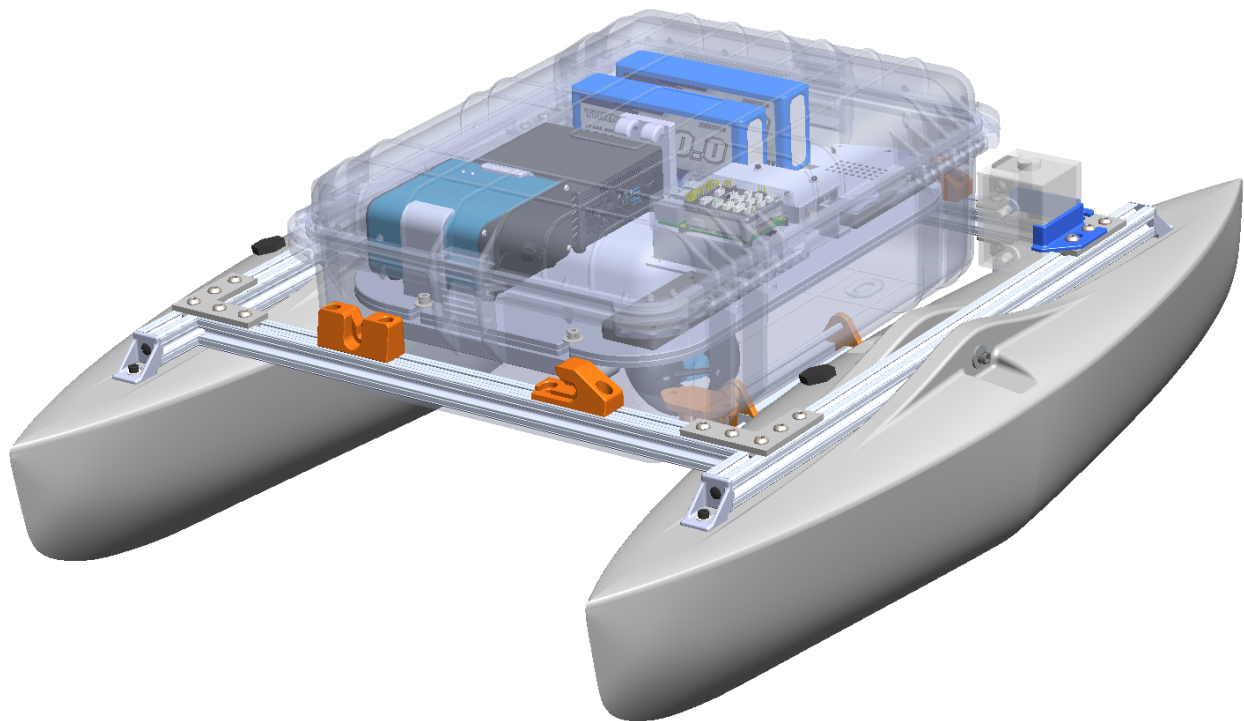
**Figure 10:** CAD of ASV housing inner structure

The surface vehicle will consist of two levels (analogous to a building with 2 floors on them.) The second fact is that the general electrical component shown will be laid out the top level whereas the bottom level is reserved for a diaphragm pump responsible for the recirculation of water as a part of the cooling system.

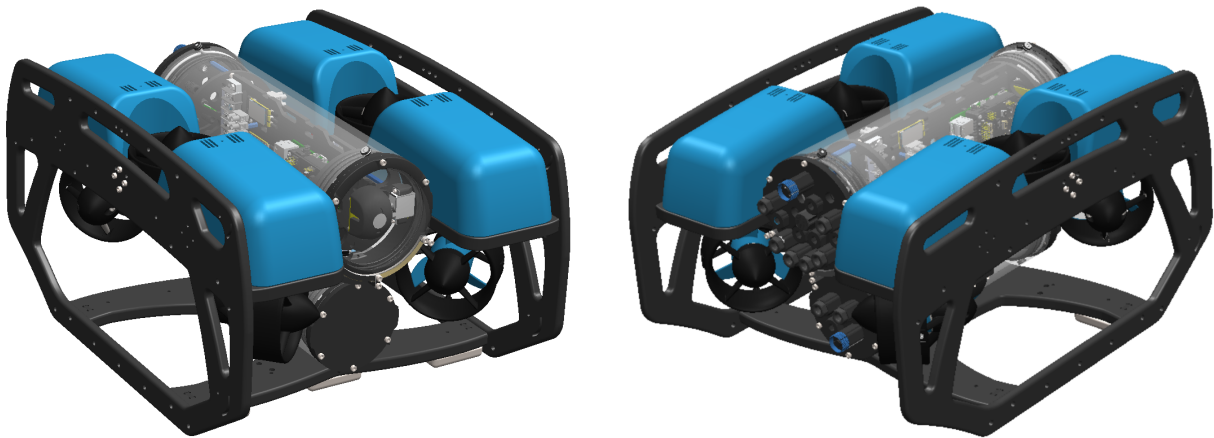


**Figure 11:** Electrical wiring diagram for the inner components of the surface vehicle.

The next CAD models generated were of the surface vehicle chassis which consists of pontoons connected by 1.0" T-Slotted 80/20 framing rails. A 90 degree bracket was also designed for fastening to the pontoons at four separate locations for added integrity. Atop the pontoons and framing rails lies the waterproof case – holding the system previously shown. The CAD models for these components required precise modeling (and surfacing) to ensure that any simulation or model-testing run on our system was as accurate as possible (for CFD and FEA).

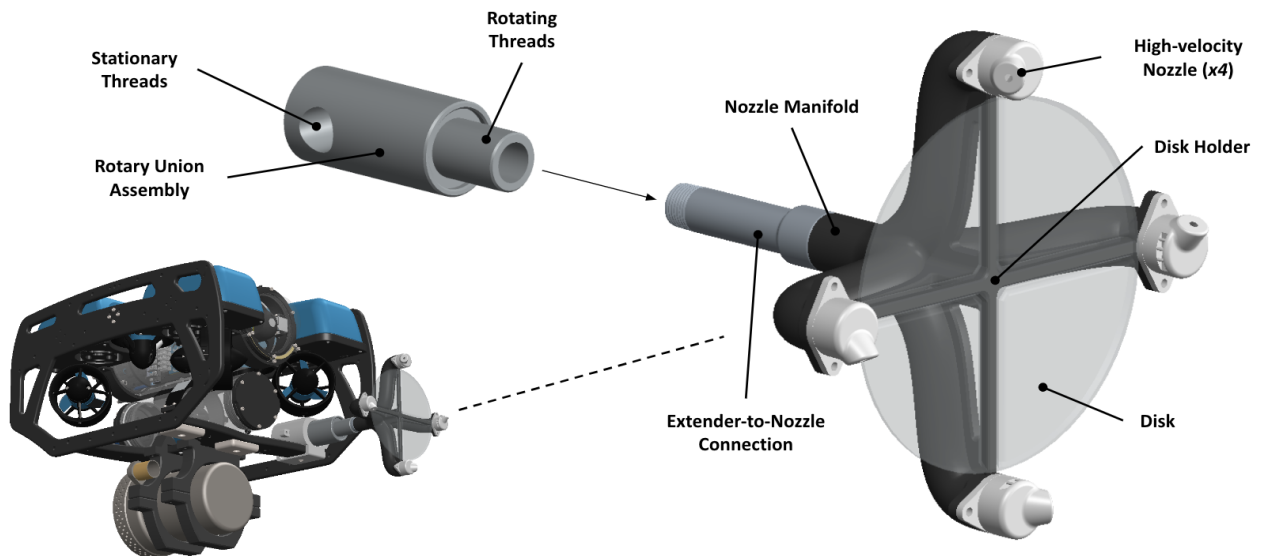


**Figure 12:** Final ASV assembly model (industrial case transparent).

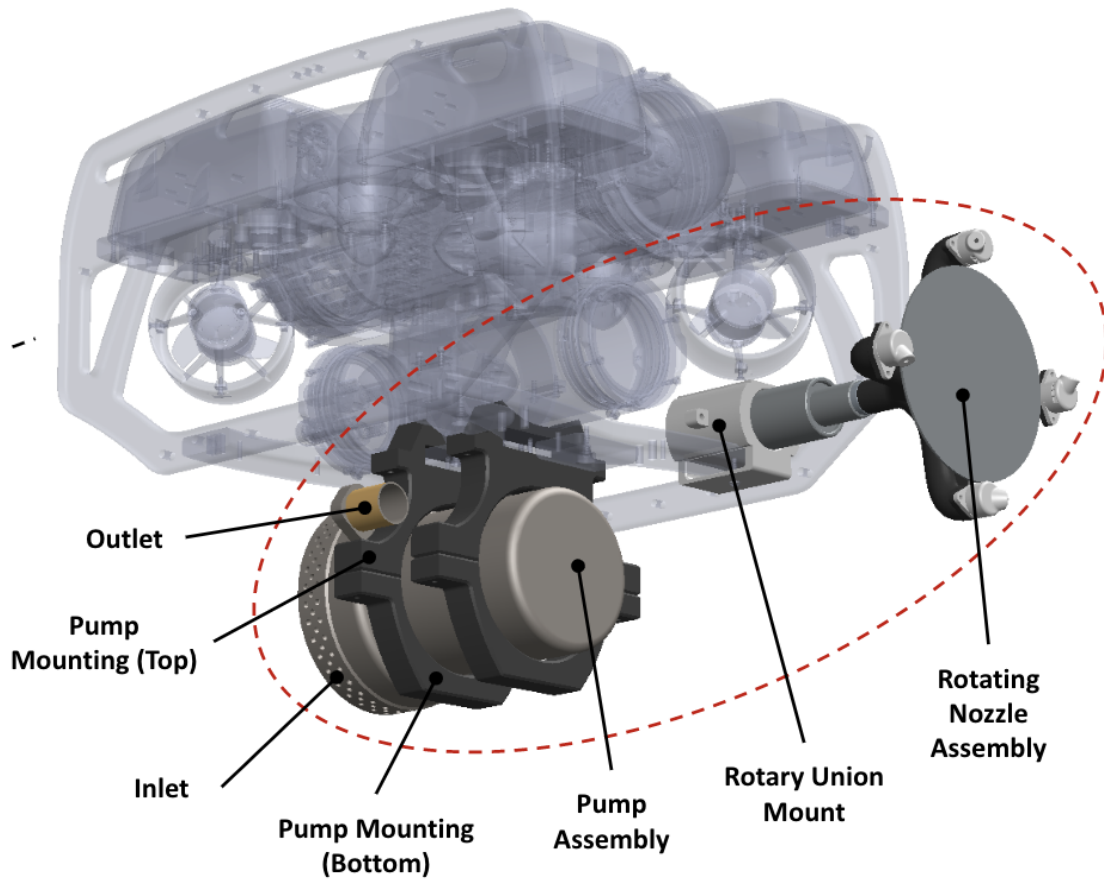


**Figure 13:** Final AROV assembly model (front view on left, rear view on right).

The final assembly is of the cleaning mechanism design attached to the BlueROV, which serves as the underwater vehicle component. Structures were developed in CAD to connect the mechanisms components to the BlueROV, and are shown below alongside the pump, disk, rotary union, and jet nozzles. The platform of the BlueROV is highly versatile, which enables easy mounting options and the addition of these vehicle subsystems. Future teams will have the option to integrate even more systems, if necessary (these could include sonar, lights, auxiliary units, etc.)



**Figure 14:** Final cleaning mechanism rotating-nozzle subassembly. Underwater vehicle shown left.

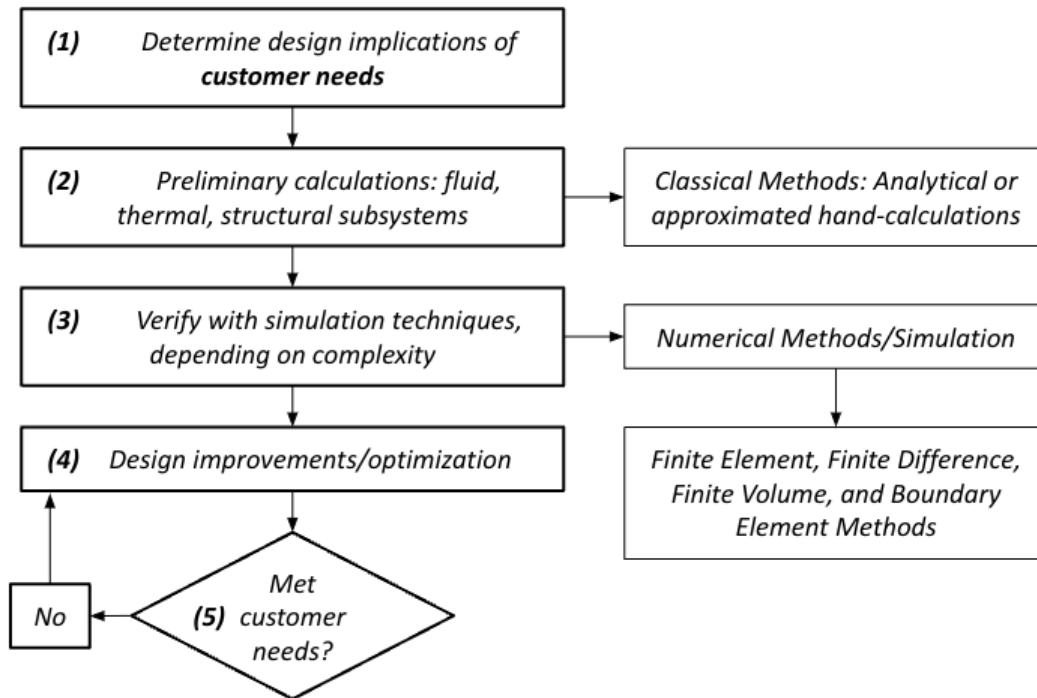


**Figure 15:** Final cleaning mechanism assembly fully integrated with underwater vehicle.

## 5 Validation

### 5.1 Component Level

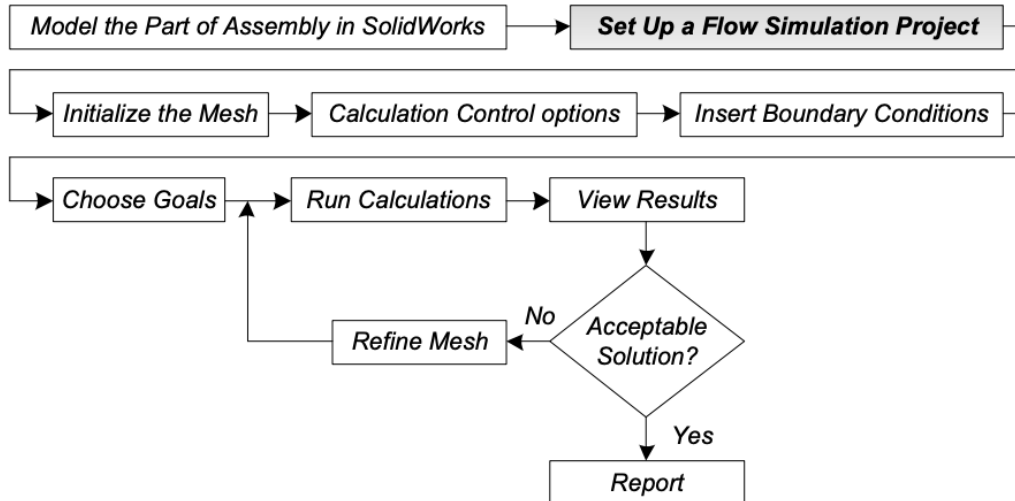
Synthesizing a theoretical design in CAD and arbitrarily determining its worthiness of proper operation is not sufficient. Numerical and mathematical analysis on vehicle components and subsystems is necessary to verify initial goals and target specifications to ensure the design iteration will fully meet customer needs. These calculations can be as little as basic hand-calculations or analytical methods, or as far-reaching as multimillion-cell computational fluid dynamics (CFD) simulations. If the numerical results yield a failure to meet the customer needs criteria, more design iterations are necessary. A flow diagram of this process is illustrated below in Figure 15.



**Figure 16:** General Process Flow of Numerical/Mathematical Analysis.

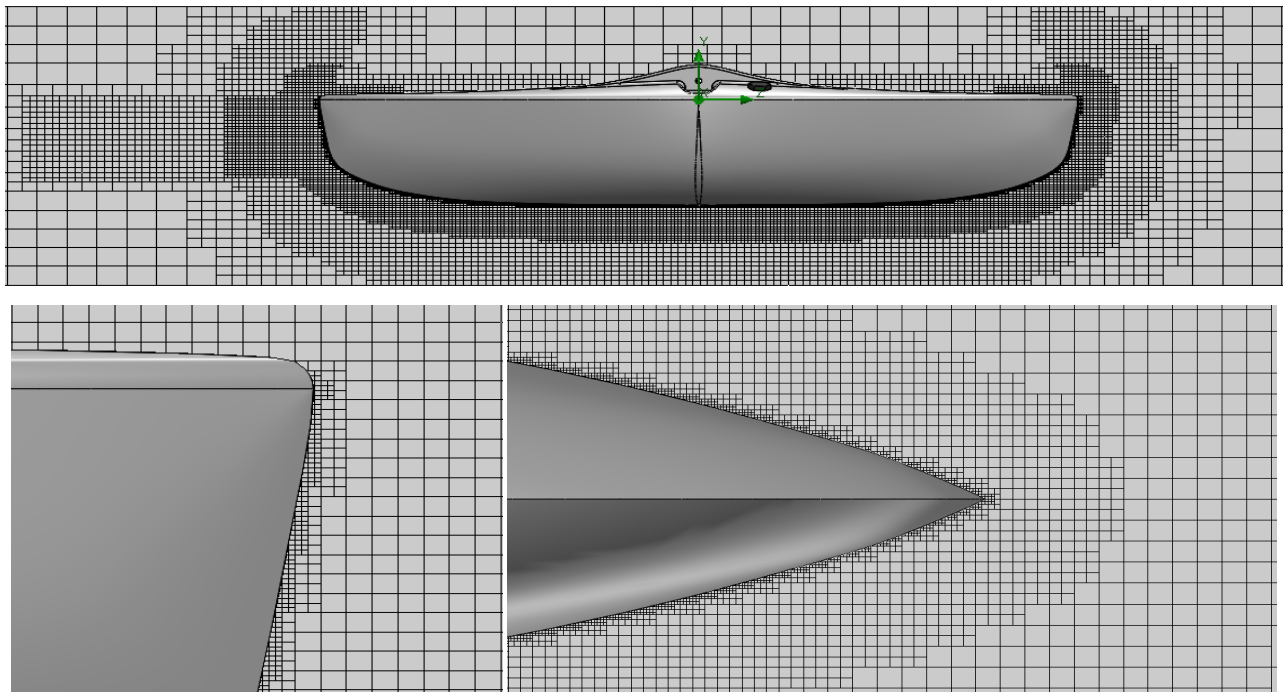
There were some notable calculations and simulations explored. Due to our system’s inevitable interaction with water as an incompressible fluid, it was imperative to understand and predict how our vehicle would perform in an oceanic environment. (1) Our ASV outer mold line (OML) pontoon design needed to be simulated in CFD to model the energy losses of the system (from drag, waterlogging, and turbulence) along with (2) our thruster design to minimize mounting height (for easy transportation) and ensure no air was present in the freestream inlet diameter.

While the design process often receives the most time and attention, developing and validating nuanced, creative constraints and assumptions can truly make or break a design in practice. When initializing any simulation of a part or assembly, it is absolutely imperative to model the part as accurately as possible, accurately and meticulously apply the boundary/initial conditions, meshing, loads, constraints, etc. to ensure a high-fidelity result. An example process flow of a CFD simulation using SolidWorks (SW) Flow Simulation® is shown in Figure 16 below.



**Figure 17:** Algorithm for analysis initialization, calculation, and post-process in SW Flow Simulation.

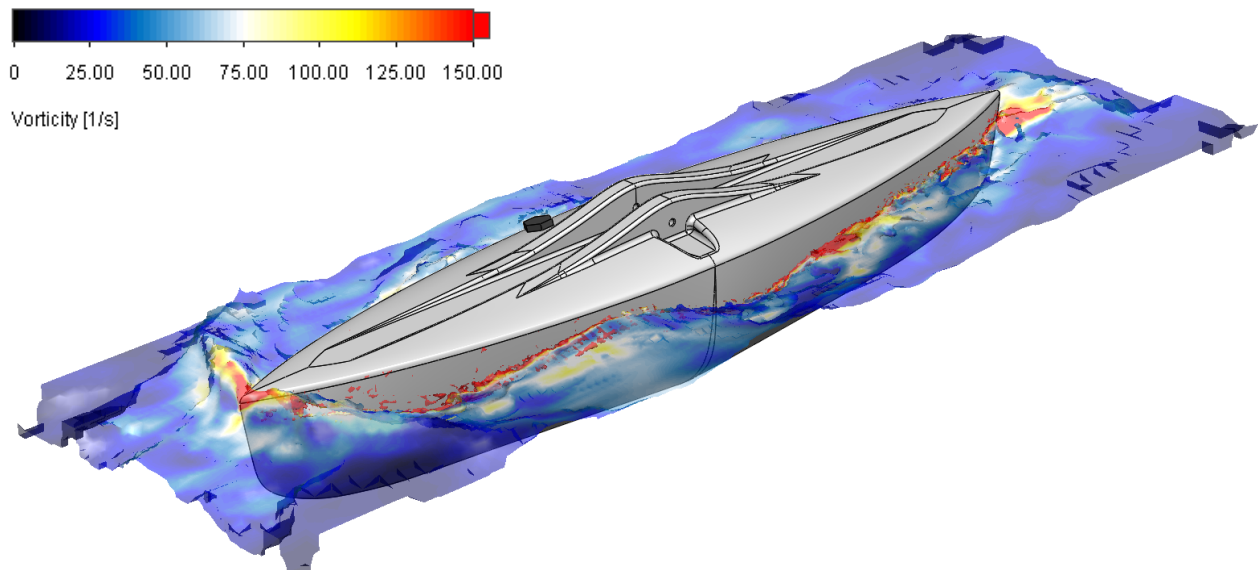
Illustrated below in the following figures is the single pontoon OML structure being meshed and simulated. The mesh contained 1.5 million cells with 7x refinement at the solid boundary after a preliminary boundary layer calculation was performed.



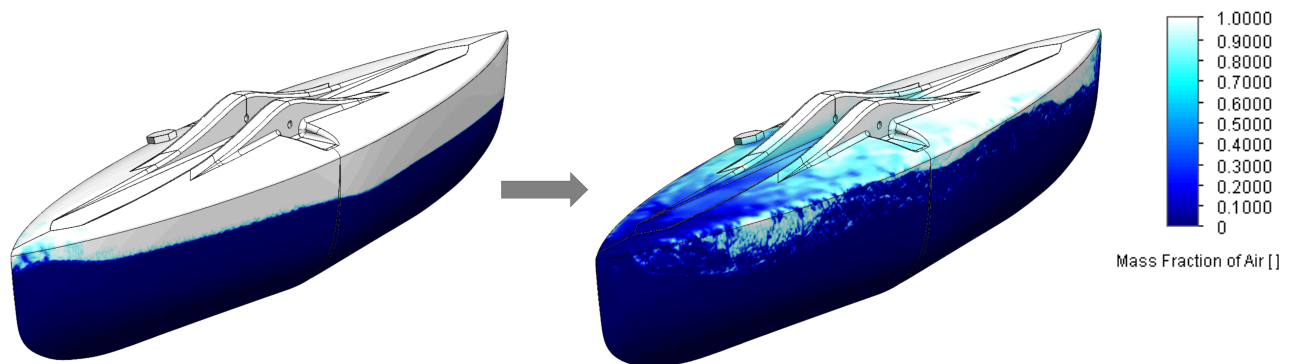
**Figure 18:** Pontoon OML mesh (note refinement increases towards solid boundary).

The following assumptions, boundary and initial conditions were initialized:

- Transient simulation (3.0 second maximum), free surface flow
- Convergence goals: Force (Z), Velocity (relative error =  $1.0E-6$ )
- Immiscible fluid interaction (air and water)
- Initial water height experimentally obtained
- 3.0 microinch surface roughness (approximated)
- 2.0 MPH velocity applied to initial flow field (relative motion to pontoon)



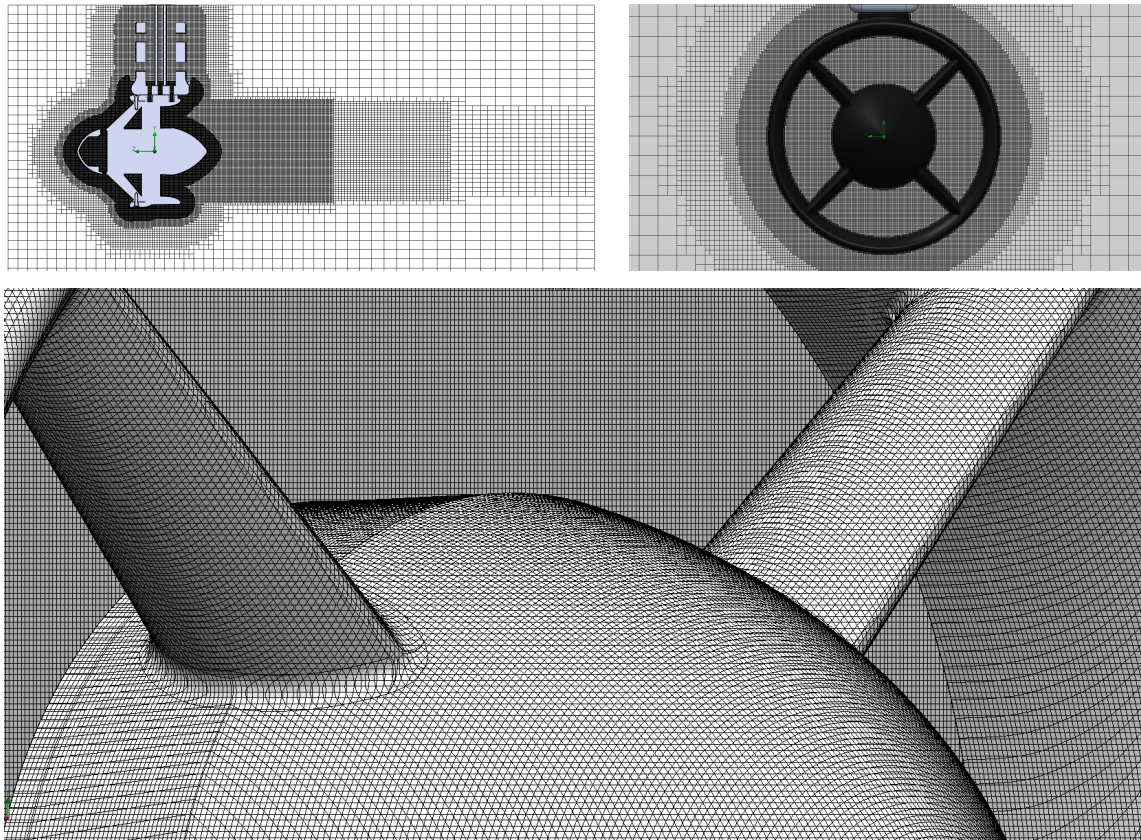
**Figure 19:** Isosurface plot of 99% mass fraction water with vorticity intensity.



**Figure 20:** Transient surface plot of water trajectory. Thin film of water on the pontoon top was minimal and did not yield significant waterlogging effects.

Some notable results included that the drag coefficient ( $C_d$ ) of a single body was about 0.052, while the force in Z ( $F_z$ , flow direction) was  $-0.159$  lbs. and the frictional force in Z ( $F_{f,z}$ ) was  $-0.081$  lbs. After further calculations, these numerical results yielded that the surface vehicle would have approximately 2.1 hours of operation at an average 35% throttle input. This satisfied our customer needs as the vehicle would be a highly efficient system.

Next, the thruster system was analyzed. Using fan curve performance and experimentally obtained values from BlueROV T200 data sheet, an appropriate steady-state solution could be determined. Below are the mesh results of the thruster underwater, with over 9 million cells and 8x refinement at the rotating fan blades. A local mesh was also added behind the body for added accuracy of the turbulent outwash.

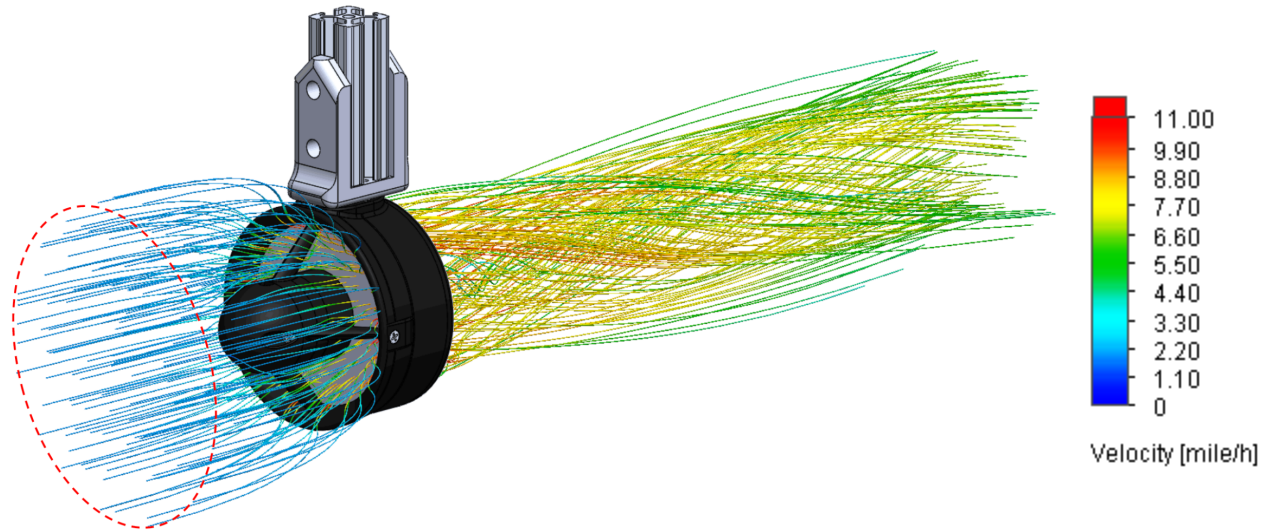


**Figure 21:** Thruster mesh cut and surface plots (right and front planes, outlet nozzle).

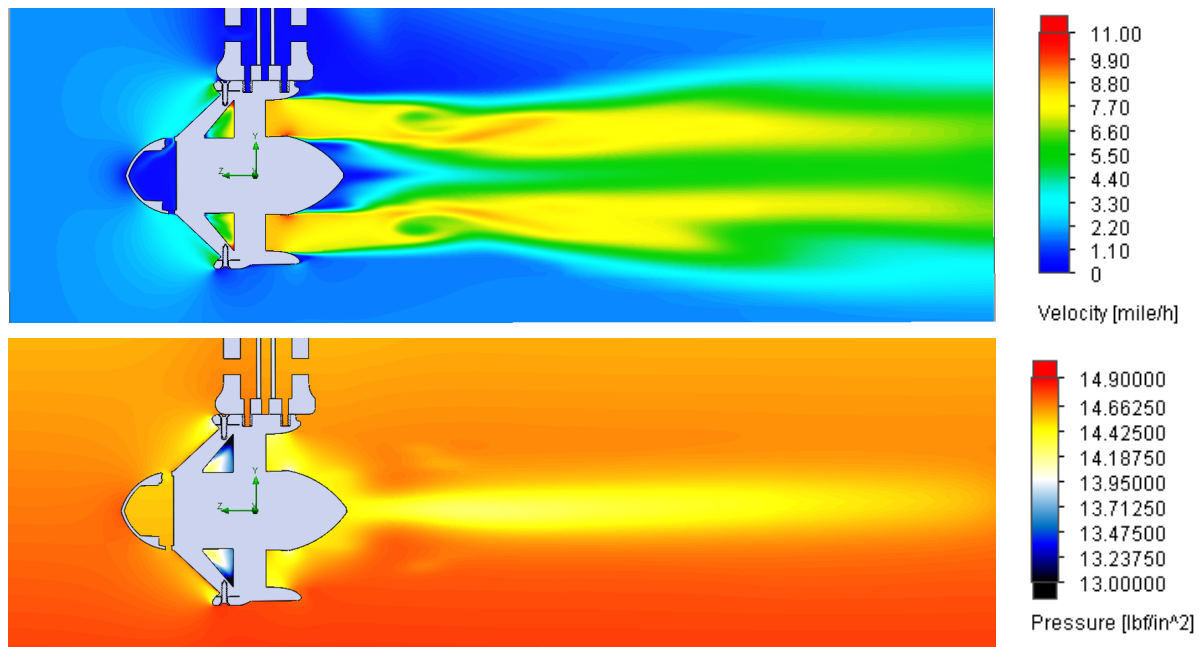
The following assumptions, boundary and initial conditions were initialized:

- Steady-state simulation (no time-dependent convergence)
- Convergence goals: Velocity (X, Y, Z) (relative error =  $1.0E-6$ )
- Computational domain contained only water
- 4.0 microinch surface roughness (approximated)
- 5.0 MPH velocity applied to initial flow field (not static thrust), matched with fan curve





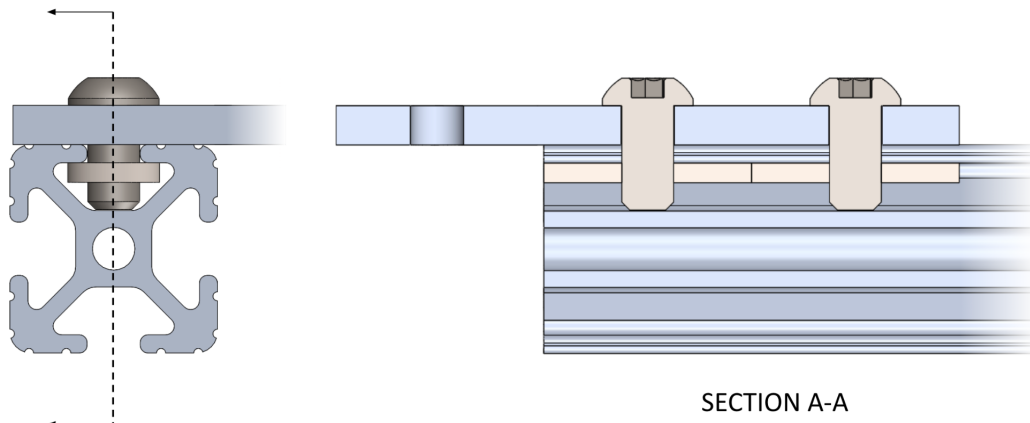
**Figure 22:** Thruster flow trajectories with velocity intensity (red circle is freestream diameter).



**Figure 23:** Thruster velocity and pressure cut plots.

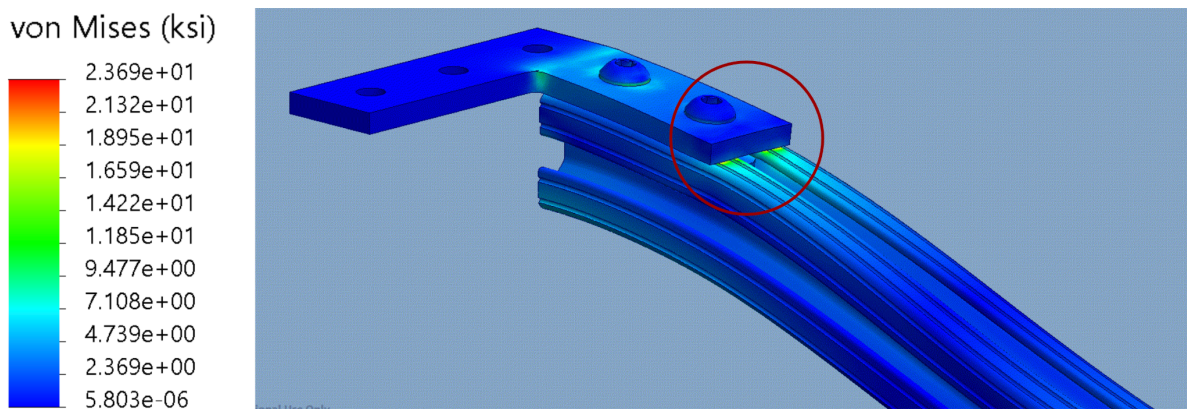
Some notable results included that minimum thruster height needed to be 1.88 inches from the water surface so the free stream diameter would have no interaction with the surface of the water (and hence intake air, reducing efficiency). This also helped minimize the dimensional size of the vehicle for easier transportation and less risk of damaging the protruding thruster mounting. The thrust force was 12.59 lbs. while the propulsive efficiency was 19% (surrounding water was moving significantly slower than exit velocity).

Lastly, structural analysis was necessary on particular subsystems of the surface vehicle to ensure that it could endure mishandling or abuse loading from the user (such as being dropped and hit). Many finite-element (FEA) analysis simulations were performed, but only one is shown below. The integrating structure of our design incorporated aluminum T-slotted 1.0 inch-thick 80/20 framing for ease of mounting and versatility.



**Figure 24:** 80/20 t-slotted framing cross section and fixtures.

The beam was fixed at either end and was tested under various different loading scenarios. Although beams can be typically modeled with hand-calculations, the complex cross sectional area of this type required FEA. The loading applied and beam constraints (fixed, roller, etc.) to the beam was distributed in different shaped areas using the split line feature in SolidWorks.



**Figure 25:** Deflected beam with von Mises stress magnitudes indicated on surface.

Some notable results included that the maximum stress ( $\sigma_{max}$ ) endured was 24.0 ksi, which did not approach the yield strength ( $S_y$ ) of AL6061-T6 of 38.0 ksi. A stress concentration was present at the top of the beam, which was expected as this portion was in tension. This satisfied our customer needs and additionally leaves room for lightweighting of the structure of next year's design team to explore.

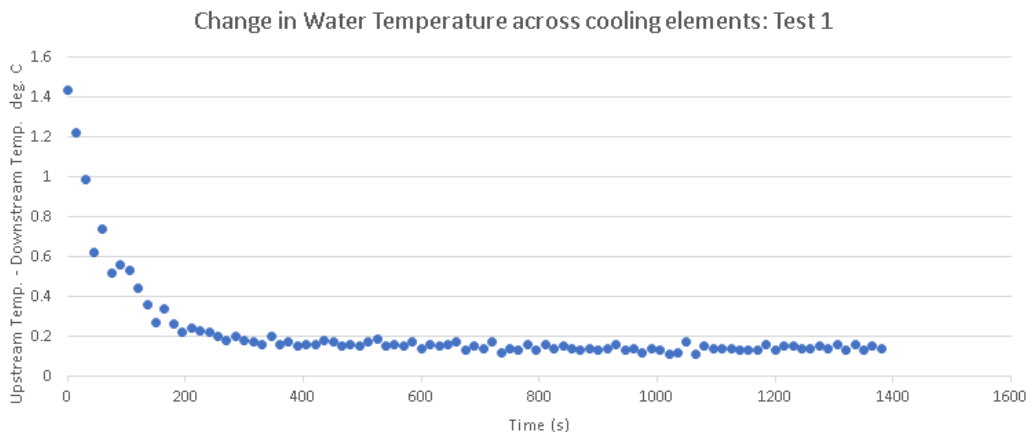
## 5.2 System Level

A pair of temperature studies were conducted to assess the performance of the cooling system and to determine if the design was in accordance with target specifications. The dissipation of heat is integral in the long term operation of the ASV and as such, supports the ASV range target specification. Since the cooling system draws power from the ASV's power system, the efficiency of the system supports the battery life target specification.

The studies collected temperature data from six points in the system: ambient air and water, coolant temperature upstream and downstream of the external cooling element, and air temperature inside the house near the top and near the bottom of the housing. The system was run at full throttle for approximately 25 mins. The weather conditions were recorded in the field notes for these outdoor tests.

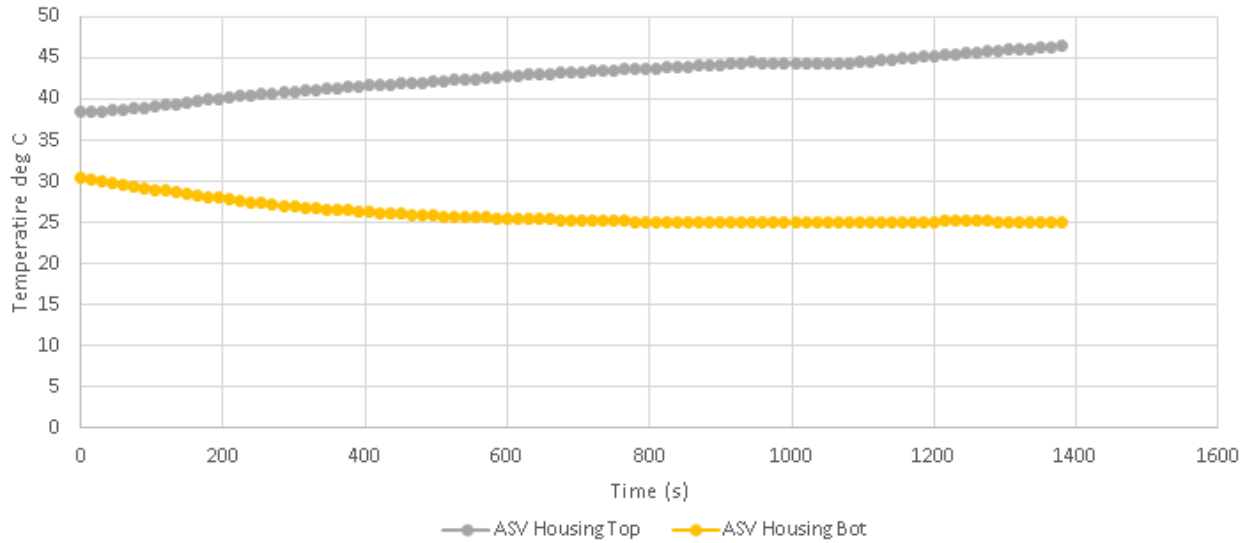
The first of the temperature studies was performed on the base configuration of the cooling system. In this configuration, the only powered component is the pump. This pump is rated for up to 12V. However with the battery life target specification in mind. The power to the pump was set to 3.5V. This configuration, using minimal power, can serve as a baseline for future iterations of the system. The flow tests that were used to calculate the mass flow rate of the water through the system were performed at this pump power. Data from the flow tests are in Appendix E.

The results of the first test showed that in the base configuration the temperature drop across the cooling elements was about  $0.15^{\circ}\text{C}$  (Figure 25a). When combined with the measured flow rate. This corresponds to a heat dissipation rate of 12W. The estimated waste heat of the internal electronics is 30W. Based on this test, further improvements on the cooling system are justified. This is supported by the data collected from inside the ASV housing. After 700s the air in the bottom of the housing appears to reach steady state, while the air in the top of the housing continues to rise throughout the duration of the test (Figure 25b). This indicates that the capacity of the system tops out before all the heat in the system can be removed.



**Figure 26a:** Temperature-drop across external cooling elements in base configuration.

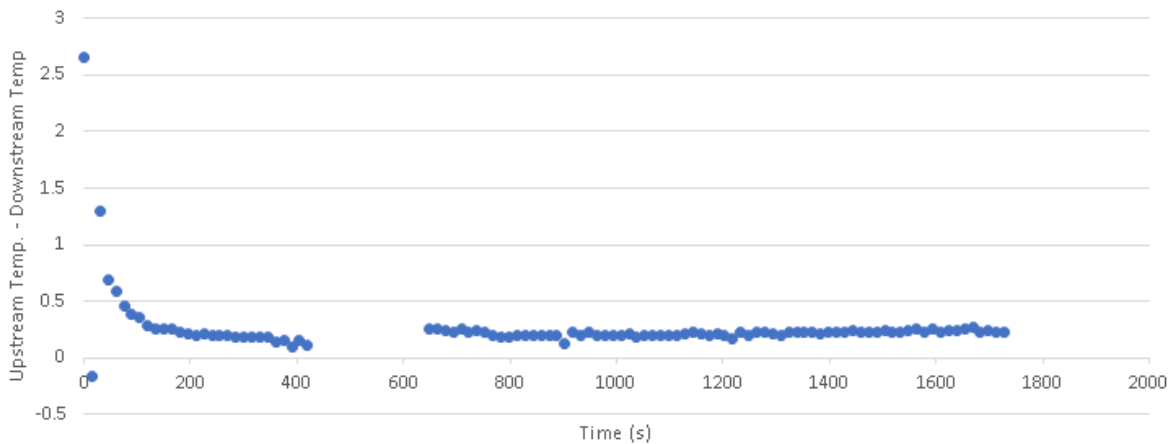
### Internal Temperatures: Test 1



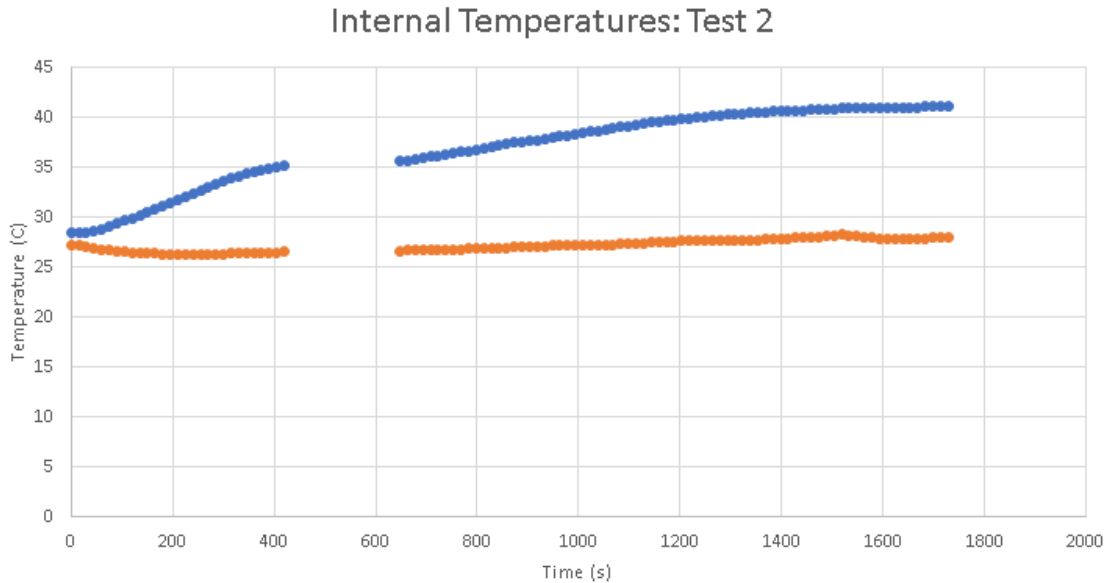
**Figure 26b:** Bulk-average temperature of air at housing top and bottom (Test 1).

The second test was performed following the installation of two small 5V, 0.2A cooling fans. These fans were positioned under the power converters near the center of the electrical and control systems. The results of this test are shown in Figure 26. This configuration of the system dissipated 16W of heat. This is still below the 30W target, however the temperature at the top of the housing did rise much more slowly than in Test 1. The gap in the data from ~420s to ~620s was due to issues with the wireless temperature sensors.

### Change in Water Temperature across cooling elements: Test 2



**Figure 27a:** Temperature-drop across external cooling elements (Test 2).



**Figure 27b:** Bulk-average temperature of air at housing top and bottom (Test 2).

The data from the two tests suggests that the addition of the fans significantly improved the performance of the cooling system. It is likely that further improvements are possible with the addition of more fans.

## 6 Operations Manual

### 6.1 ASV Operation

#### *ASV Operation Required Equipment:*

- Computer running Windows and has the Windows Remote Desktop Program. This will be referred to as the ‘base computer’
- Wifi Router. The system has been configured to work well with the Netgear Nighthawk router included in the ASV equipment set. This router network is called “NETGEAR21”.
- Wifi router power cable
- Logitech wireless game controller with usb dongle
- ASV Component Checklist:
  - 4S (14.8V) 10Ah LiPo batteries (2x)
  - ASUS Mini PC (typically mounted inside the ASV)
  - Raspberry Pi + Navigator Flight Controller (typically mounted inside the ASV)
  - Ethernet Cable
- [Field Tests Only] Power Inverter to power the wifi router off a car’s 12V power outlet. Included in the ASV equipment set.

*ASV Set-Up and Operation:*

1. Plug in and power on the wifi router within range of the operating area.
2. Ensure the ASV internal components are connected properly
  - a. The PC should have three things plugged into it.
    - i. Power cable
    - ii. Ethernet cable
    - iii. Logitech usb dongle

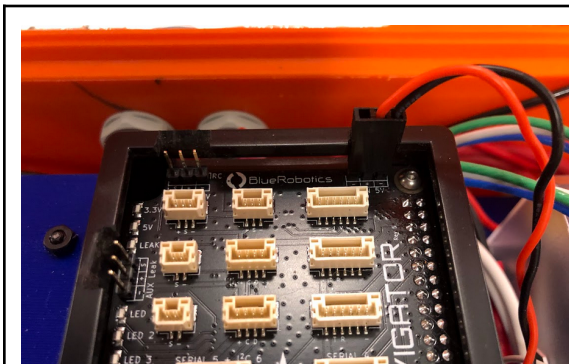


Ethernet Cable and Power Plug for PC

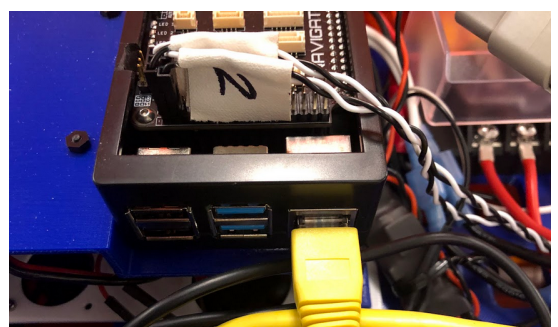


Wireless Controller USB dongle

- b. Check connections on the Raspberry Pi and Flight Controller
      - i. The Pi receives power from the 5V power converter though the pins on the top right of the the upper PCB board
      - ii. The ESCs are connected to the PWM outputs on the bottom of the upper PCB board and are labeled to correspond to PWM outputs 1 and 2.
      - iii. The ethernet cable is connected to the to the side of the Pi.



Raspberry Pi Power Connection

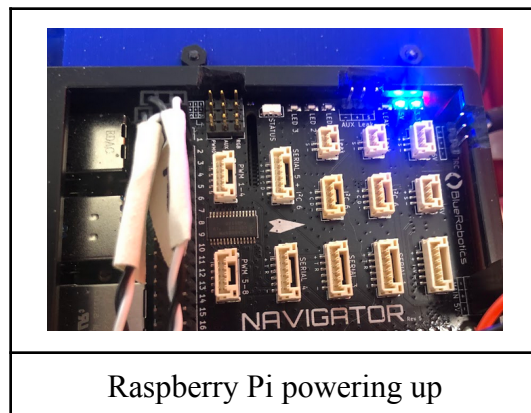


Ethernet and PWM connections

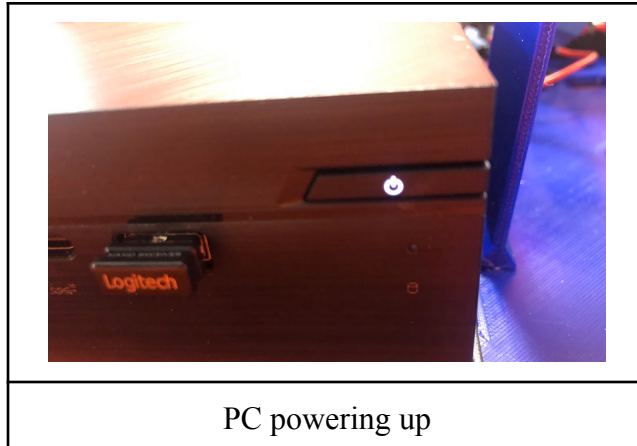
- c. Ensure the ESCs are connected to the thrusters via the gray 6-wire deutsch connector.



3. Connect the Batteries. The batteries are connected to the system in parallel with a wiring harness using T90 connectors. When the batteries are connected the Pi should automatically power up as indicated by LEDs on the top PCB board and a series of beeps.



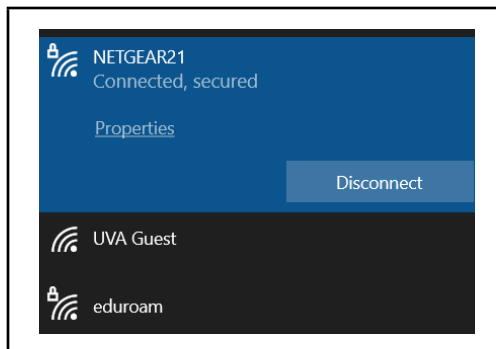
4. Power up the PC by pressing the power button on the front of the case. The power symbol on the button should light up indicating that it has power.



PC powering up

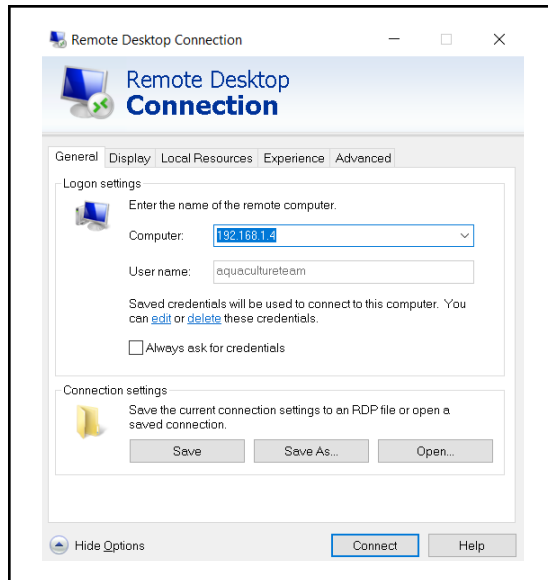
The PC is set up to automatically connect to the 'NETGEAR21' wifi network.

5. Connect to the 'NETGEAR21' with the base computer running windows. The password is on the bottom of the router.

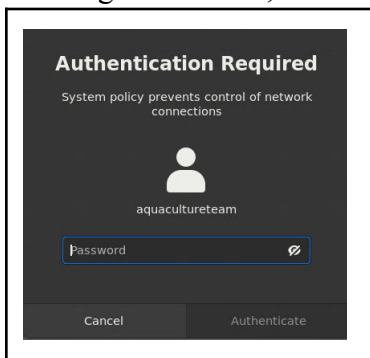


6. Open the Remote Desktop Connection Program on the base computer. It can be found with the search function in the task bar. The ASV runs Ubuntu, but uses a program called XRDP to interface with the Windows RDP program.
  - a. The PC on the ASV has been set up to have a static IP address on the NETGEAR21 network. The IP address is: **192.168.1.4**
  - b. The username on the PC is: **aquacultureteam**
  - c. The password is: **password**
  - d. Click connect to establish remote access to the ASV's PC.
  - e. Optional: Save the connection settings for faster set-up in the future.

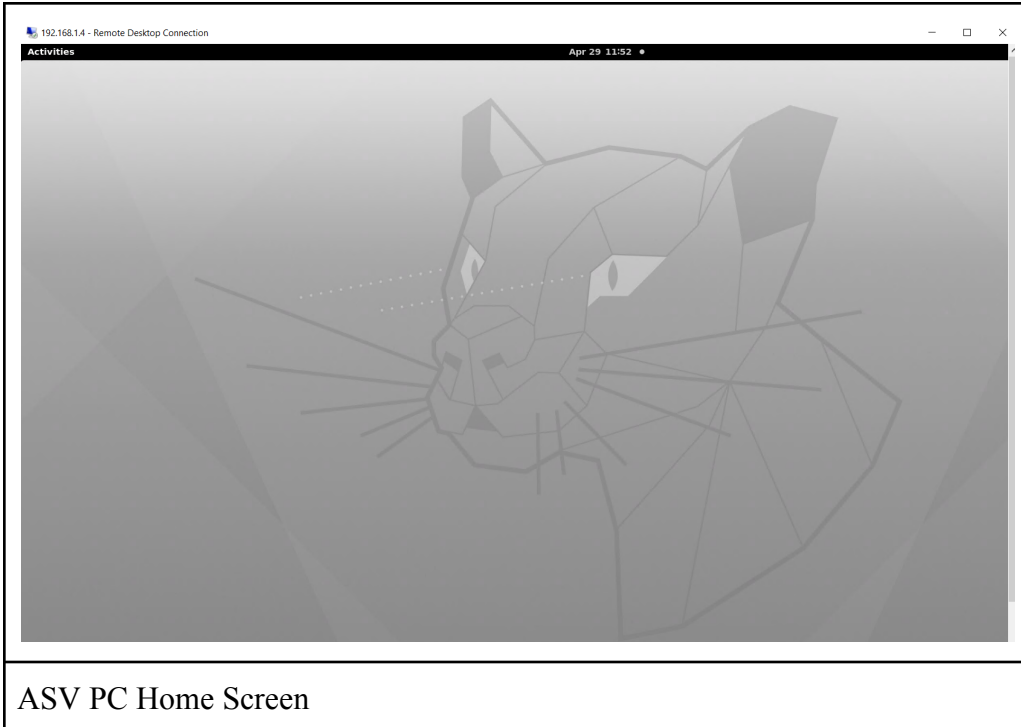




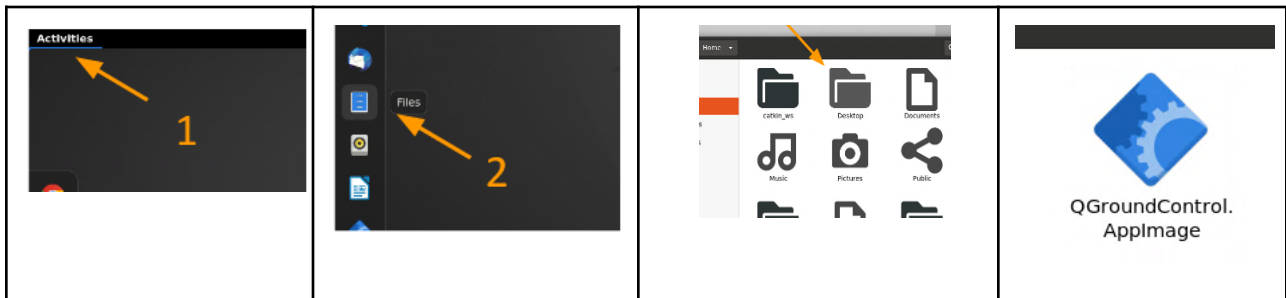
7. There will be a series of Authentication Required pop-up windows (example below). Type in the password ('password') and click Authenticate. If the pop-up window refers to the Netgear network, click cancel to bypass. These will have a different appearance.



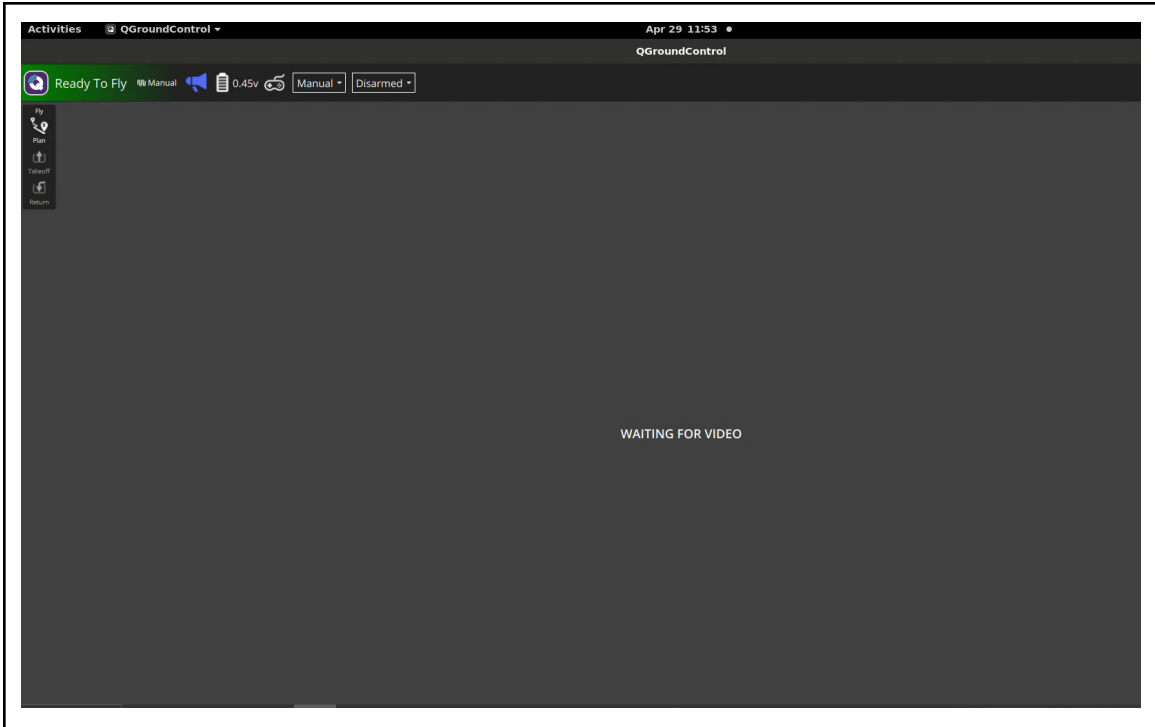
8. This is the home screen of the PC:



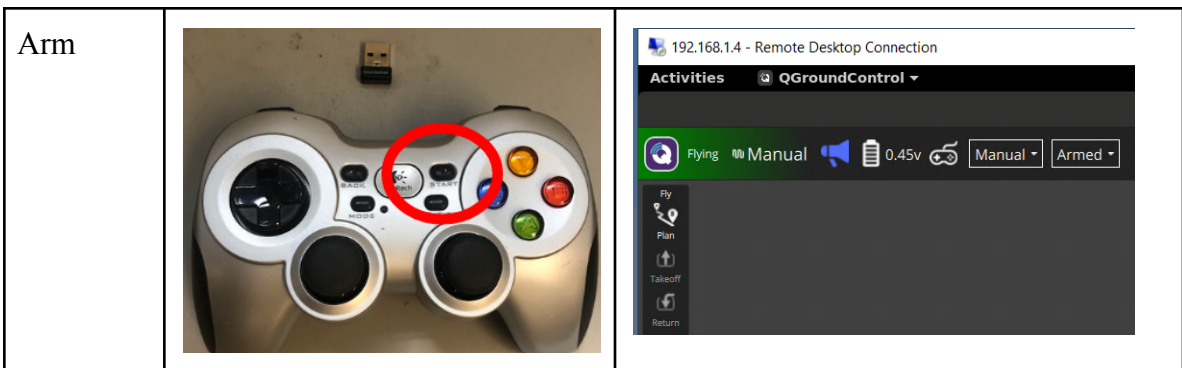
9. Open QGroundControl (QGC): Activities → Files → Desktop → QGroundControl.AppImage

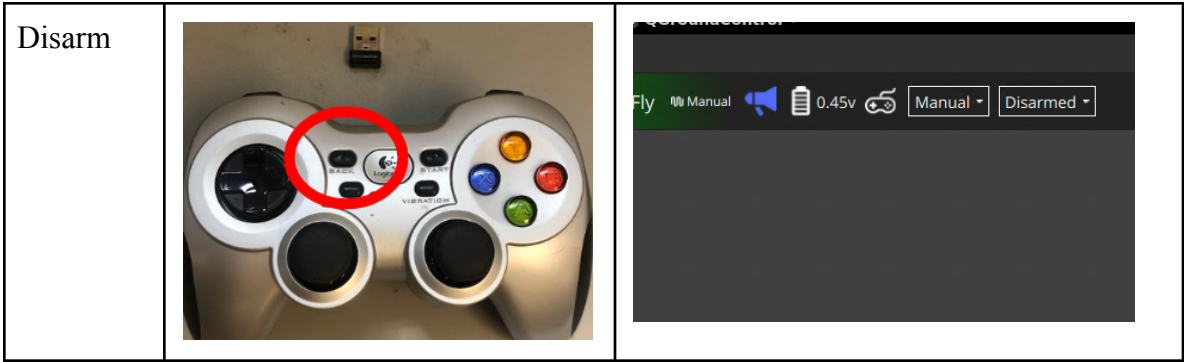


10. If the Pi has power and is connected properly to the PC, it will connect automatically to QGC. There will be a green progress bar across the top of the window as the vehicle parameters are loaded. After this you should see the screen below.

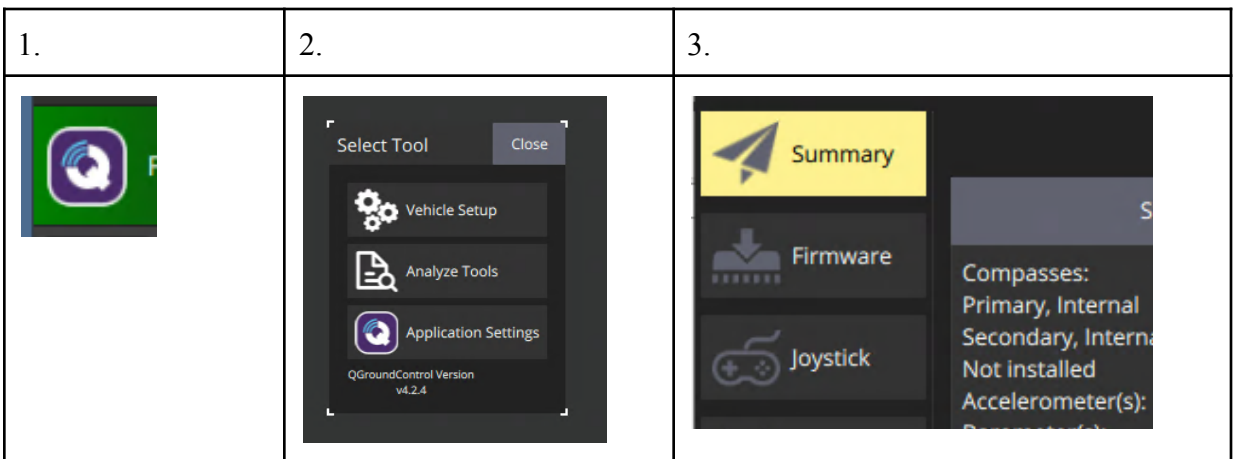


11. Test out the wireless controller by pressing the ‘start’ button’. If working properly the system will display as ‘Armed’. Moving the joysticks on the controller will send commands to the thrusters on the ASV. [NOTE: The thrusters are designed to be water lubricated and should only be run for short periods of time while not in the water.] Disarm the system by pressing the back button.

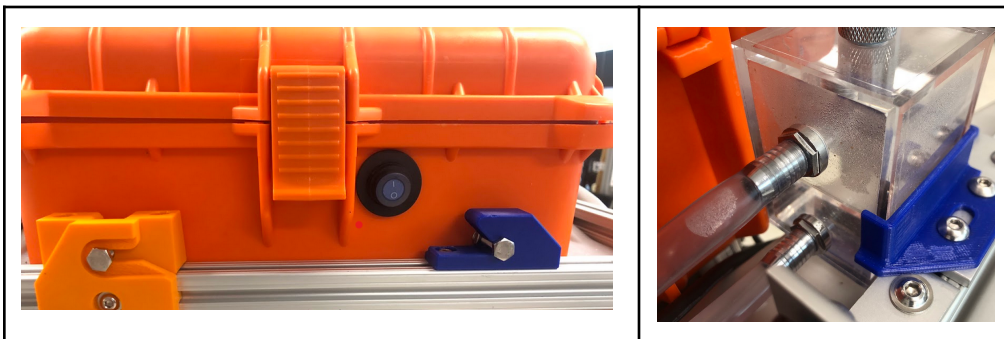




12. Optional: Reconfigure or Calibrate the Controller. The button and joystick mapping can be viewed and changed by clicking the QGC logo in the top left of the screen, then by clicking ‘Vehicle Setup’ → ‘Joystick’.



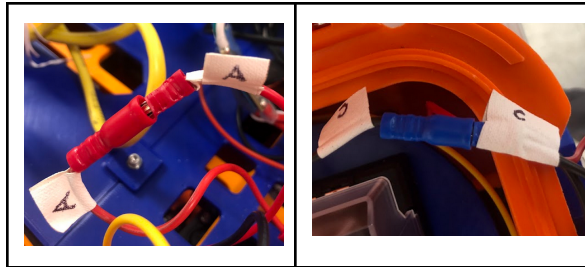
13. Run the cooling system if the ASV is operating for more than a few minutes. The system can be tuned on and off using the blue switch on the front of the ASV’s main housing. The water level of the system can be checked by looking at the transparent reservoir on the side of the ASV. If the water level is low it can be refilled using the funnel included in the ASV equipment set.



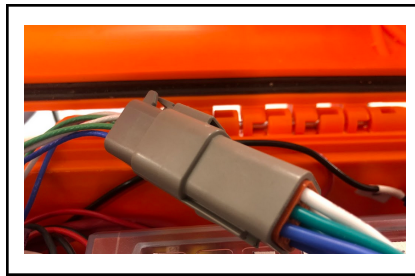
*ASV Maintenance and Disassembly:*

To access the electrical and cooling systems of the ASV, the board containing all the wiring can be removed for easier access.

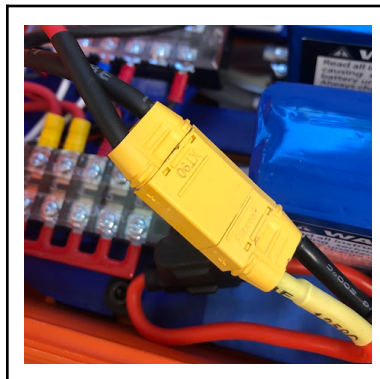
1. Disconnect the electronics from the ASV housing:
  - a. Next to the fuse box there are 2 connections that need to be unplugged before proceeding. These connections are labeled 'A' and 'C'. Connections 'B', 'D' and 'E' can stay plugged in.



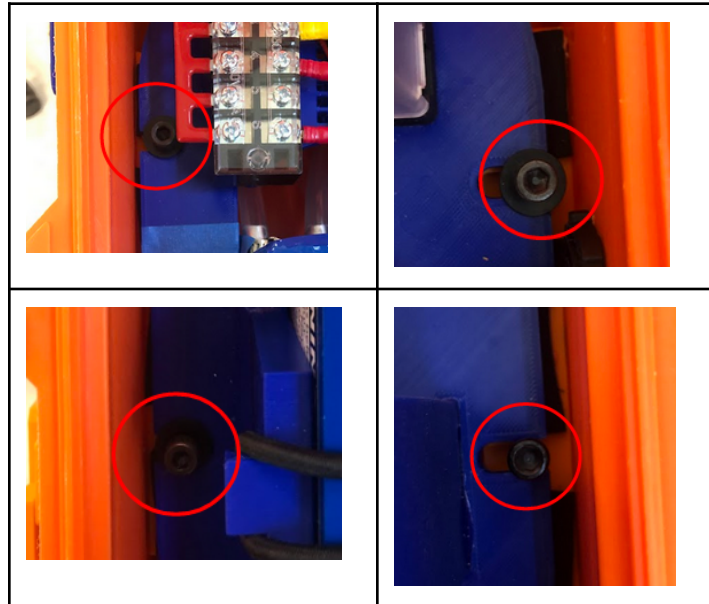
- b. Unplug the gray 6-wire plug that connects the thrusters to the ECSs.



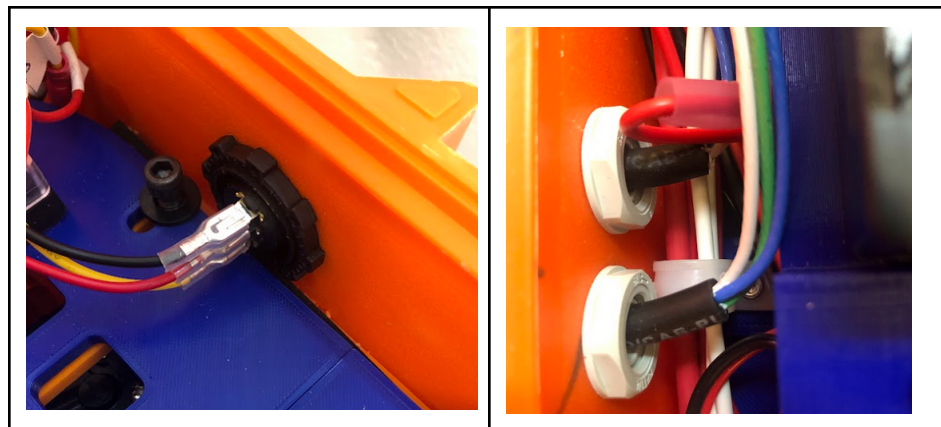
- c. Unplug the batteries. This can be done by disconnecting the T90 connection between the in-line fuse holder and the power distribution terminals next to the batteries.



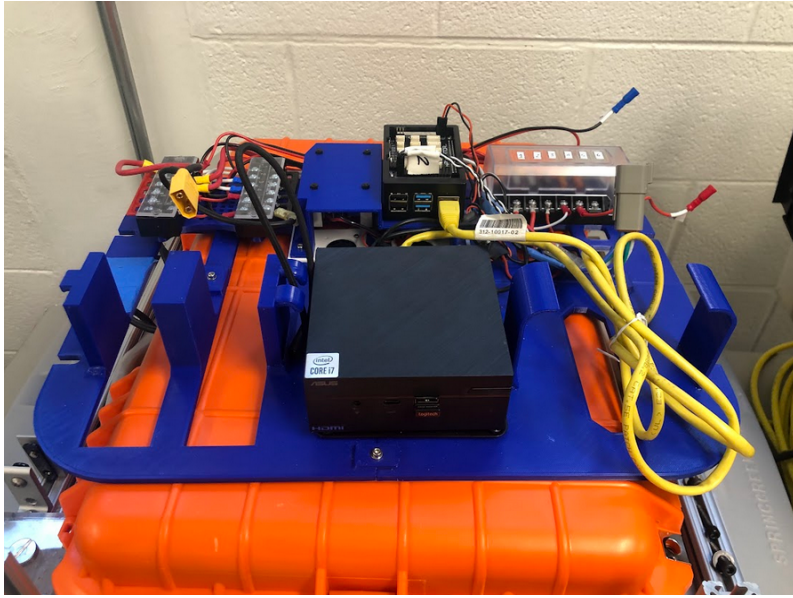
2. Remove the batteries and set them aside or they will likely fall out as the electronics mounting board is removed.
3. Remove the four screws holding the blue board in place. This will require a 3/16 in hex wrench.



4. Lift up on the side of the blue board towards the rear of the ASV. Be mindful of the wire terminals on the backside of the cooling pump switch at the front end of the housing, as well as the wires entering the housing from the thrusters behind the power converters. The board can catch on these wires.



5. When the back end of the board has cleared the lip of the housing, the board can be slid out of the housing. Providing access to the wiring, and the cooling system below.



Removed electronics board



Cooling System and support structures

## 6.2 AROV Operation

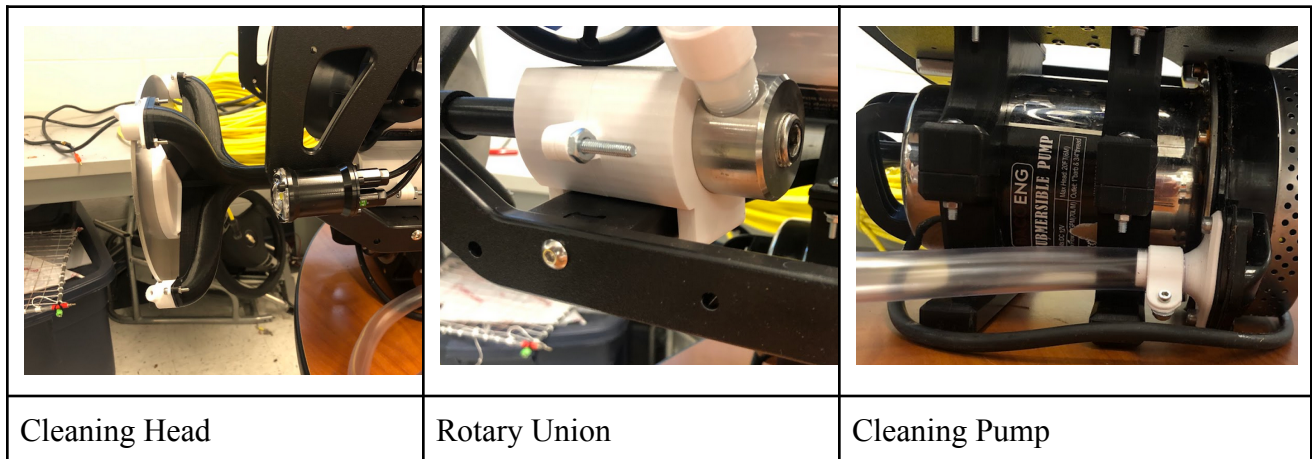
### *AROV Operation Required Equipment:*

- Computer with QGroundControl (QGC) installed. This will be referred to as the ‘base computer’
- PhantomX Tether interface w/ usb cable
- BlueROV2
- Vacuum hand pump
- 2.5mm hex wrench
- ROV Battery
- Game Controller

For ROV dive prep and operation instructions we refer to the official BlueRobotics instructions found at: <https://bluerobotics.com/learn/bluerov2-operation/>

### *Cleaning System Set-Up and Operation:*

Ensure the pump, rotary union and cleaning head are oriented properly on the AROV. The following images can be used as reference.



### Equipment:

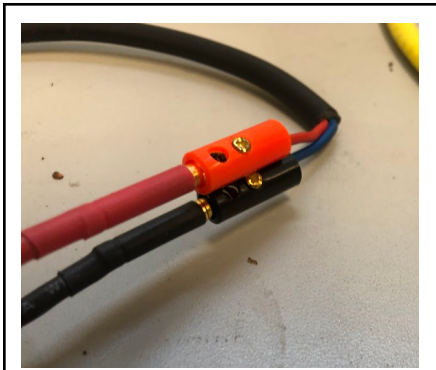
- 12V DC power supply. The power supply shown below is stored on the battery charging shelf in the drone room of VICTOR lab.





12V DC power supply

1. Submerge the ROV with the attached cleaning system.
  - a. The power cord of the cleaning pump needs an external power supply. Run the power cord for the pump along with the tether for the ROV out of the water to the base control area. Do not plug the pump in before the pump is submerged.
2. Once in the water, the pump can be powered up. It is suggested that a power strip with a switch be used to toggle power on and off to the pump. The power cord for the pump can be plugged into the power supply as shown below.



Cleaning Pump Power cord connection to the 12V DC power supply

3. Once the pump powers up, the water coming out of the nozzles will provide the thrust that rotates the cleaning head.

### 6.3 Troubleshooting

Problem	Potential Solution or Fix
QGC is not connecting to the Raspberry Pi Flight Controller.	Check that the ethernet cables are fully inserted into the ethernet ports on the Pi and the PC.
QGC is connected and armed, but the motors are not responding.	Confirm that the ESCs are connected to the motors through the gray 6-wire connector.
The cooling system pump is on but no water is circulating.	If the system appears to have enough water; there may be air bubbles blocking the water flow. Try rocking the ASV all the way to one side (90deg from horizontal) then to the other. Repeat this several times as the air bubbles work their way out of the system.
Windows RDP is not connecting to the PC in the ASV.	Double check that your base computer is still connected to NETGEAR21. Occasionally computers will disconnect from networks that don't have internet access and join networks that do.
The ROV camera feed is not showing up in QGC.	If you are using a base computer running Ubuntu 18.04 this is a known issue with no known solution. Try using a base computer running a different OS.

## **7 Conclusions and Future Work**

### **7.1 Summary**

Through the aforementioned design process, our team was able to develop both the remotely-operated surface vehicle and a potential cleaning mechanism for the underwater vehicle. The surface vehicle met several target specifications, which were verified through different tests and analyses – these include weight limits, operational lifespans, range capabilities, and simplicity. Additionally, the cleaning mechanism developed has proven capable of removing debris from net-like surfaces, without causing any damage. While the long term goal is a fully autonomous system with co-navigational capabilities, remote-operation is a key step in this process and lays the groundwork for future teams to improve upon our design and ultimately reach that goal.

### **7.2 Future Work**

Future work could focus on the refinement of our design in various manners. The main focus should be programming both the BlueROV2 (underwater vehicle) and the surface vehicle to operate as a single system and to introduce low to mid-level autonomy. Additional avenues for future work include design and building of a docking mechanism capable of holding the surface vehicle while it recharges, increasing the complexity of the vehicles' navigational abilities (i.e. adding more sensors and developing co-navigation functionality), and reducing the weight of the surface vehicle to make it capable of greater speeds and maneuverability.

In terms of improvements for the cleaning mechanism, a level of stability in terms of buoyancy must be developed for the underwater vehicle. While the cleaning mechanism does work properly, it alters the center of mass for the device and greatly impacts its ability to float evenly above and below water. The cleaning mechanism will also need to be integrated into the power system of the AROV. This could involve the installation of additional watertight housing to hold another battery, more wiring or power system infrastructure.

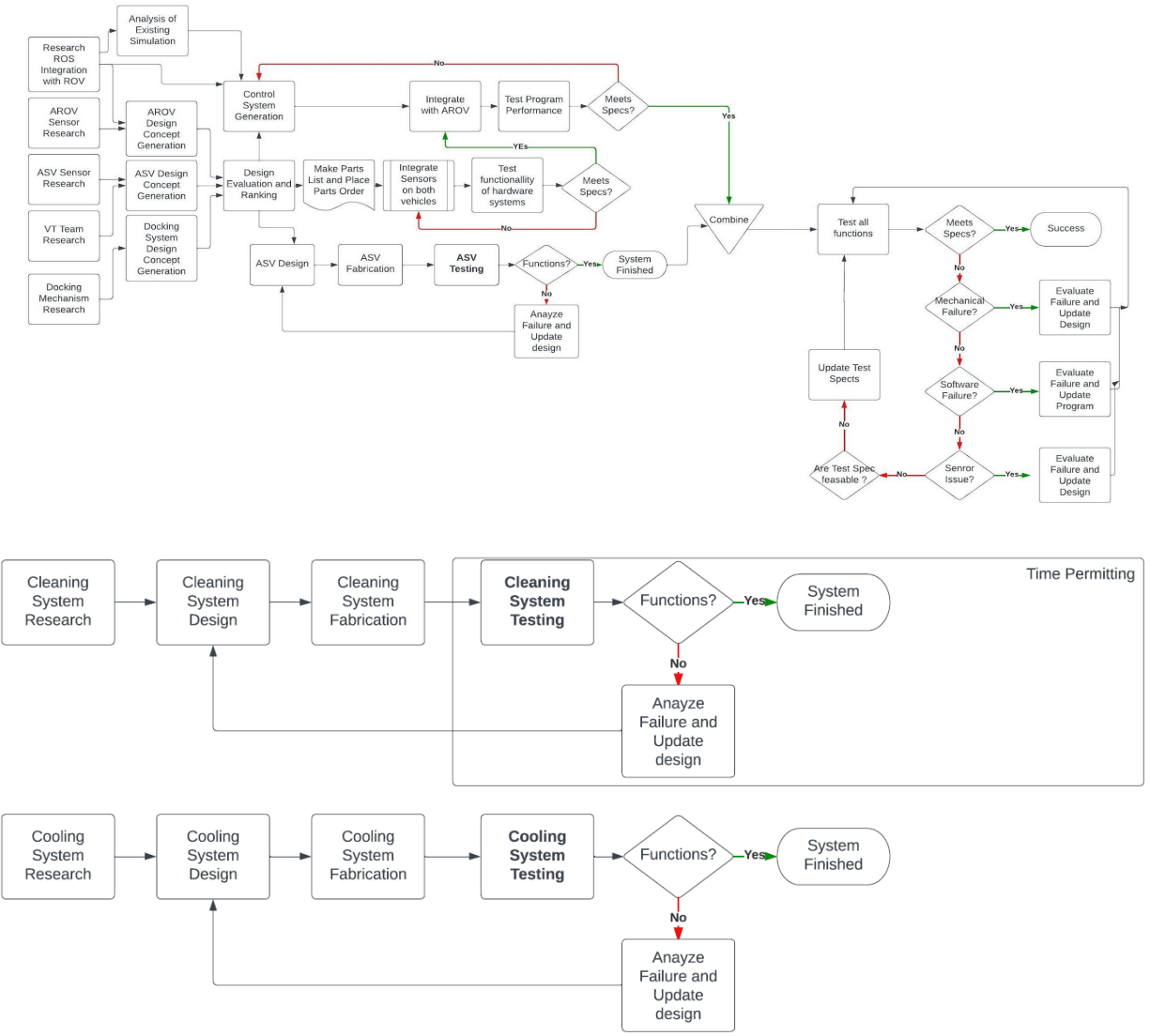


## References

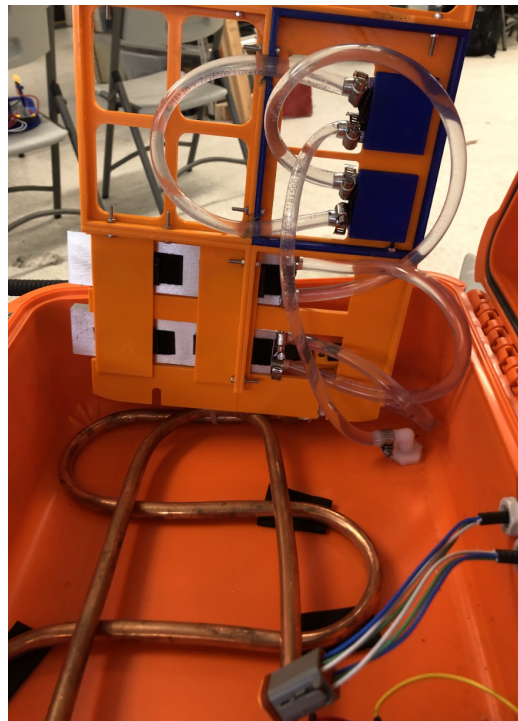
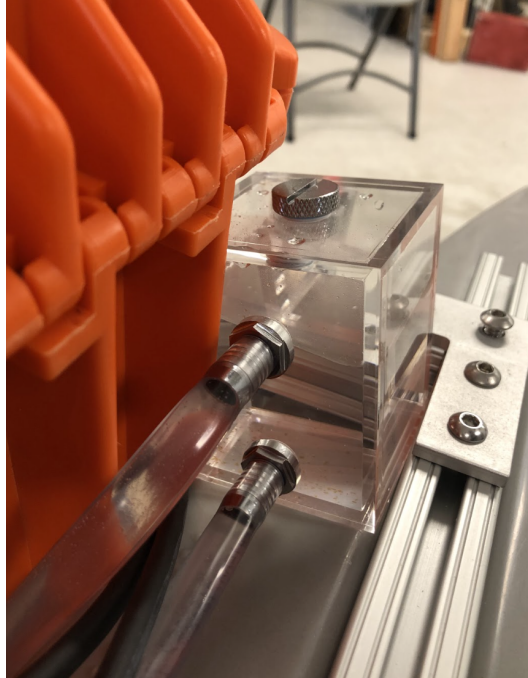
- Aquaculture: Occupational diver certification*. ADAS. (2022, May 6). Retrieved December 7, 2022, from <https://adas.org.au/careers/aquaculture/>
- FAO (2022) Food and Agriculture Organization of the United Nations. The State of World Fisheries and Aquaculture. (report) [www.fao.org/publications/sofia/2022/en](http://www.fao.org/publications/sofia/2022/en)
- J. Lindsay *et al.*, "Collaboration of Heterogeneous Marine Robots Toward Multidomain Sensing and Situational Awareness on Partially Submerged Targets," in *IEEE Journal of Oceanic Engineering*, vol. 47, no. 4, pp. 880-894, Oct. 2022, doi: 10.1109/JOE.2022.3156631.
- Mainstay. (2022, March 30). *Mainstay RM3*. Mainstay AS. Retrieved December 7, 2022, from <https://mainstay.no/products/mainstay-racemaster/>
- Naylor R, Burke M, and Wrigley J (2005, June 14) Aquaculture and Ocean Resources: Raising Tigers of the Sea. *Annual Review of Environment and Resources* 30, 185-218.
- Remora Robotics. (n.d.). *A robot that cleans and inspects fish pens while collecting data*. Autonomous Cleaning Robot – Remora Robotics. Retrieved December 7, 2022, from <https://remorarobotics.no/autonomous-cleaning-robot/>
- Sun, X *et al.* (2021) Reimagining Autonomous Underwater Vehicle (AUV) Charging Stations with Wave Energy. *Berkeley Scientific Journal*
- Talke, K., Birchmore, F. & Bewley, T. (2022) Autonomous hanging tether management and experimentation for an unmanned air-surface vehicle team. *Journal of Field Robotics*, 39, 869– 887. <https://doi.org/10.1002/rob.22083>

# Appendices

## Appendix A: Finalized Schematic of Project Design Process.



**Appendix B: Additional Photos of the Cooling System**  
*Copper tubing and pump setup, water reservoir, and full system shown.*



## Appendix C: Concept Screening Outcomes

### Control Software

Potential Solution → Selection Criteria ↓	QGroundControl	ROS
Cost	+	+
Complexity	0	-
Multi-Vehicle Capabilities	+	+
Existing Functionality	+	+
User-Friendly	+	-
Hardware Compatability	+	0
Sum +'s	5	3
Sum 0's	1	1
Sum -'s	0	2
Net Score	5	1
Rank	1	2
Continue?	Yes	Yes

### Cleaning Mechanism

Potential Solution → Selection Criteria ↓	Robotic Pinchers	Nets	Brushes	Water Jets
AROV charging cycle *	-	0	0	0
Cost	+	+	+	+
Weight	-	+	+	+
Length Dimensions	-	-	+	+
Large Scale Cleaning**	+	+	0	+
Small Scale Cleaning**	0	0	+	0
Cleaning Speed	+	+	-	+
Sum +'s	2	4	4	5
Sum 0's	1	2	2	2
Sum -'s	3	1	1	0
Net Score	-1	3	3	5
Rank	4	2	2	1
Continue?	No	Yes	Yes	Yes



### Cooling System

Solution →		Open System		Closed System	
Selection Criteria ↓	Weight	Rating	Weight	Rating	Weight
Energy Consumption	20%	4	0.8	4	0.8
Cost	15%	5	0.75	4	0.6
Weight	15%	3	0.45	3	0.45
Efficiency	20%	3	0.6	3	0.6
Resilience	30%	2	0.6	4	1.2
	<b>100%</b>		3.2		3.65
		<b>RANK</b>	2		1

### Appendix D: Concept scoring outcomes

#### Control Software

Solution →		QGroundControl		ROS	
# Selection Criteria ↓	Weight	Rating	Weight	Rating	Weight
1 Cost (Minimize)	10%	5	0.5	5	0.5
2 Complexity	30%	4	1.2	2	0.6
3 Multi-Vehicle Capabilities	20%	3	0.6	3	0.6
4 Existing Functionality	20%	5	1	2	0.4
5 User-Friendly	5%	4	0.2	1	0.05
6 Hardware Compatability	15%	5	0.75	2	0.3
	<b>100%</b>		4.25		2.45
		<b>RANK</b>	1		2

#### Cleaning Mechanism

Solution →		Nets		Brushes		Water Jets	
# Selection Criteria ↓	Weight	Rating	Weight	Rating	Weight	Rating	Weight
1 AROV charging cycle	20%	5	1	5	1	5	1
2 Cost	20%	4	0.8	2	0.4	4	0.8
3 Weight	15%	3	0.45	3	0.45	2	0.3
4 Length Dimensions	10%	3	0.3	3	0.3	4	0.4
5 Large Scale Cleaning**	5%	5	0.25	4	0.2	4	0.2
6 Small Scale Cleaning**	15%	4	0.6	5	0.75	5	0.75
7 Cleaning Speed	15%	3	0.45	4	0.6	4	1.8
	<b>100%</b>		3.85		3.7		5.25
		<b>RANK</b>	2		3		1

Cooling System I

Solution →		Open System		Closed System	
Selection Criteria ↓	Weight	Rating	Weight	Rating	Weight
Energy Consumption	20%	4	0.8	4	0.8
Cost	15%	5	0.75	4	0.6
Weight	15%	3	0.45	3	0.45
Efficiency	20%	3	0.6	3	0.6
Resilience	30%	2	0.6	4	1.2
	<b>100%</b>		3.2		3.65
		<b>RANK</b>	2		1

Cooling System II

Solution →		Water Cooled		Artificial Coolant	
Selection Criteria ↓	Weight	Rating	Weight	Rating	Weight
Energy Consumption	20%	5	1	4	0.8
Cost	15%	5	0.75	1	0.15
Weight	15%	3	0.45	3	0.45
Efficiency	20%	3	0.6	4	0.8
Resilience	30%	5	1.5	4	1.2
	<b>100%</b>		4.3		3.4
		<b>RANK</b>	1		2

Appendix E: Mass Flow Rate Analysis of the Cooling System

				Calculation
Run #	measured mass (g)	minus container (g)	time (s)	Mass Flow Rate (g/s)
1	323	195.5	10.19	19.2
2	346	218.5	11.2	19.5
3	341	213.5	10.41	20.5
4	335.5	208	10.61	19.6
container tare (g)	127.5		<b>Ave. MFR (g/s)</b>	<b>19.7</b>