

Optimization of Carbon-Neutral Production of Methanol Via Direct Air Carbon Capture

A Technical Report submitted to the Department of Chemical Engineering

Presented to the Faculty of the School of Engineering and Applied Science
University of Virginia • Charlottesville, Virginia

In Partial Fulfillment of the Requirements for the Degree
Bachelor of Science, School of Engineering

Spring, 2023

Technical Project Team Members

Alexandra Cresci

Zexian He

Nick Hoessle

Cameron Williams

On my honor as a University Student, I have neither given nor received unauthorized aid on this assignment as defined by the Honor Guidelines for Thesis-Related Assignments

Eric Anderson, Department of Chemical Engineering

TABLE OF CONTENTS

| | |
|-------------------------------------------------------------------------|-----------|
| SUMMARY | 5 |
| I. INTRODUCTION | 7 |
| II. PREVIOUS WORK | 9 |
| 2.1 Direct Air Capture Previous Work | 9 |
| 2.1.1 Carbon Engineering | 9 |
| 2.1.2 2022 Carbon-Neutral Production of Methanol Via DAC Capstone Group | 10 |
| 2.1.3 Existing Modeling Research | 10 |
| 2.2 Methanol Synthesis Previous Work | 11 |
| 2.2.1 The CAMERE Process | 11 |
| III. DISCUSSION | 12 |
| 3.1 Overall Design Basis | 12 |
| 3.1.1 Direct Air Capture Design Basis | 15 |
| 3.1.2 Methanol Synthesis Design Basis | 16 |
| 3.2 Direct Air Capture Design | 18 |
| 3.2.1 Air Contactor | 18 |
| Unit Design | 18 |
| Energy Analysis | 19 |
| Material Balance | 20 |
| Modeling Via Aspen Plus | 20 |
| 3.2.2 Pellet Reactor | 21 |
| Unit Design | 21 |
| Energy Analysis | 21 |
| Material Balance | 22 |
| Modeling Via Aspen Plus | 22 |
| 3.2.3 Calciner | 23 |
| Unit Design | 23 |
| Energy Analysis | 24 |
| Material Balances | 25 |
| Modeling Via Aspen Plus | 25 |
| 3.2.4 Direct Air Capture Heat Exchanger Design | 27 |
| Modeling via Aspen | 27 |
| Heat Exchanger E-301 | 28 |
| Heat Exchanger E-302 | 28 |
| Heat Exchanger E-303 | 28 |
| 3.2.5 Slaker | 30 |
| Unit Design | 30 |

| | |
|----------------------------------------------|-----------|
| Energy Analysis | 31 |
| Modeling Via Aspen Plus | 31 |
| Slurry Valve | 32 |
| 3.2.6 Pump and Conveyor Design | 32 |
| Pumps | 32 |
| Conveyors | 33 |
| 3.3 Methanol Synthesis Design | 34 |
| 3.3.1 Reverse Water-Gas Shift Reactor System | 34 |
| Unit Design | 34 |
| Catalyst | 35 |
| Energy Analysis | 35 |
| Residence Time | 36 |
| Pressure Drop | 36 |
| Auxiliary Equipment | 38 |
| 3.3.2 RWGS Condenser System Design | 39 |
| Unit Design | 39 |
| Energy Balance | 39 |
| Material Balance | 39 |
| Modeling Via Aspen Plus | 40 |
| 3.3.3 Hydrogenation Reactor System | 41 |
| Unit Design | 41 |
| Catalyst | 42 |
| Residence Time | 42 |
| Pressure Drop | 42 |
| Energy Analysis | 42 |
| Modeling Via Aspen Plus | 43 |
| Auxiliary Equipment | 44 |
| 3.3.4 Hydrogenation Condenser System | 45 |
| Unit Design | 45 |
| Energy Analysis | 45 |
| Material Balance | 45 |
| Modeling Via Aspen Plus | 46 |
| 3.3.5 Methanol Distillation Column Design | 47 |
| Modeling Via Aspen Plus | 47 |
| Material Balance | 49 |
| IV. ECONOMICS | 50 |
| 4.1 Operating Schedule | 50 |
| 4.2 Annual Revenue | 50 |

| | |
|-------------------------------------------------------------|-----------|
| 4.3 Purchased Equipment and Capital Costs | 51 |
| 4.3.1 Major Equipment | 51 |
| 4.3.2 Ancillary Equipment | 52 |
| 4.3.4 Total Capital Cost of Plant | 53 |
| 4.4 Operating Costs | 54 |
| 4.4.1 Raw Materials | 54 |
| 4.4.2 Labor Costs | 55 |
| 4.4.3 Utility Costs | 56 |
| 4.4.4 Waste Costs | 59 |
| 4.5 Cost of Manufacturing | 60 |
| 4.6 Cash Flow Analysis | 62 |
| 4.7 Scenarios | 63 |
| V. ENVIRONMENTAL CONSIDERATIONS | 67 |
| 5.1. Direct Air Capture | 67 |
| 5.1.1 Waste Streams | 67 |
| 5.2 Methanol Synthesis | 68 |
| 5.2.2 Waste Streams | 68 |
| VI. SAFETY CONSIDERATIONS | 69 |
| 6.1 Chemical Hazards and Compatibility | 69 |
| 6.1.1 Direct Air Capture Chemical Hazards and Compatibility | 69 |
| 6.1.2 Methanol Synthesis Chemical Hazards and Compatibility | 70 |
| 6.2 Safety Culture | 72 |
| VI. SOCIAL CONSIDERATIONS | 73 |
| VII. FINAL RECOMMENDED DESIGN | 74 |
| 7.1 Direct Air Capture and Power Island | 74 |
| 7.2 Methanol Synthesis | 78 |
| VIII. CONCLUSION AND FUTURE RECOMMENDATIONS | 82 |
| 8.1 Conclusion | 82 |
| 8.2 Future Recommendations | 82 |
| X. REFERENCES | 85 |
| XI. APPENDIX | 88 |

SUMMARY

As the effects of climate change become more apparent in modern day life, it is more urgent now than ever before to reevaluate the energy sources and production manners of industrial societies in terms of their carbon emissions. To prevent potential environmental destruction and massive weather changes, the Paris Climate Accord set a target of preventing the globe from warming above 2°C which can only be achieved by removing carbon dioxide from the atmosphere in addition to reducing future carbon dioxide emissions. The concept of capturing ambient carbon dioxide through direct air capture systems is an emerging technology with the purpose of reaching these new carbon negative industrial goals.

In this report, a direct air capture system is designed alongside a methanol synthesis system to provide a more environmentally friendly manner of producing methanol while capturing and utilizing ambient carbon dioxide. This system runs on a production schedule of 6000 hours/year with breaks in production for catalyst regeneration. In this system, 0.98 MtCO₂/year is captured and utilized to produce 0.62 Mt/year of methanol. The direct air capture system contains four units and the methanol production system has three units. The first unit, the Air Contactor captures 1.8 trillion kg/year of air and captures the carbon dioxide with an aqueous sorbent solution. The carbon dioxide is then sent through calcium caustic loop and calcium carbonate regeneration system which consists of the Pellet Reactor, Calciner, and Slaker systems. A purified stream of carbon dioxide (99.8%) leaving the Calciner is produced with a carbon dioxide rate of 0.98 MtCO₂/year. This stream is then sent to the Reverse Water-Gas Shift Reactor (RWGS) to produce a stream of carbon monoxide. In the next unit, the Hydrogenation Reactor, the carbon monoxide is converted to methanol which is then purified in the distillation column at 99% purity with a production rate of 0.62 Mt methanol/year.

Even though this project contributes directly to the global carbon reduction efforts, it is not economically feasible. Cash flow analysis indicates this plant will be losing 359 million per year as a result of high raw material costs. There are three scenarios this project could slightly generate profit: carbon credit subsidy, premium methanol, and gray hydrogen. However, these scenarios are unrealistic and lead to the conclusion that this project would not be a worthwhile investment until a more economically viable process can be determined. Here we provide a few recommendations to improve the economics of this project. The gas purge stream could be relocated to reduce hydrogen losses. The calciner could use a fire heater rather than an electric

heater, since operating an electric heater is much more expensive. More optimization recommendations could be found in the future recommendations section.

I. INTRODUCTION

As the world continues into the mid-21st century, we are beginning to see rapid weather and environmental changes due to climate change. The average temperature on Earth has risen 0.08° Celsius per decade since 1880, but this rate has more than doubled since 1981, rising 0.18° C per decade in recent years. The effects of global warming are driving regional and seasonal temperature extremes, playing a role in melting glaciers, intensifying hurricanes, extreme heat waves, and drastically altering the habitats that many life forms depend on for survival (Lindsey 2022).

Following the Industrial Revolution, carbon dioxide (CO_2) emissions from man-made sources have been increasing. Now, 87 percent of all anthropogenic carbon dioxide emissions come from burning fossil fuels (“Main sources of carbon dioxide emissions,” 2017). Our society, currently dependent on fossil fuels for energy, is being forced to reevaluate energy production due to this issue. To prevent potential environmental destruction and massive weather changes, the Paris Climate Accord set a target of preventing the globe from warming above 2°C . As the world begins to switch to renewable energy sources, scientists have stated that this alone will not prevent the climate from warming above this two degree target. Carbon dioxide will need to be removed from the atmosphere in addition to reducing the carbon dioxide that is being emitted currently.

Direct air capture (DAC) is a new type of technology that serves to decrease ambient carbon dioxide concentrations as opposed to traditional carbon capture technologies which target point source emissions. In this project, a direct air carbon capture system and methanol production plant are designed based on “Carbon-Neutral Production of Methanol Via Direct Air Carbon Capture,” a technical report submitted in 2022 by Brown, Huynh, Lee, Park, and Smith (Huynh 2022). DAC is achieved by extracting carbon dioxide from the air, and sending it through a calcium caustic loop and calcium carbonate regeneration system which consists of a Pellet Reactor, Calciner, and Slaker. Methanol production is achieved by catalytic hydrogenation of CO and H_2 syngas produced from reverse water-gas shift reactions. A distillation column purifies the methanol stream, yielding product methanol of 99.9%

This design has a number of safety, environmental, and social considerations. The main safety concerns involve waste water streams, mechanical conveyors that pose a hazard to the

operators should any accidents occur, and leaking syngas from different equipment in the process. The environmental impact of this process is beneficial since ambient carbon dioxide is being removed from the atmosphere and aiding in the reduction of climate change. The goal of this production process is to create a net-negative methanol production plant that benefits the chemical industry while also demonstrating the ability of the industry to reduce its negative impact on the planet.

II. PREVIOUS WORK

2.1 Direct Air Capture Previous Work

While it is a newer technology, direct air capture was first suggested by Klaus Lackner, a chemical engineer at Arizona State University, in 1999 as a potential method of ameliorating climate change (Ozin, 2022). As of September 2022, there are 18 direct air capture plants operating worldwide (Budinis, 2022). These plants capture around 0.01 megatonne-CO₂ per year (MtCO₂/yr), and in the United States there is a plant in an advanced development stage that aims to capture 1 MtCO₂/yr. The intended goal is to scale up to 60 MtCO₂/yr by 2030 and achieve a net zero emissions environment by 2050 (the “Net Zero Emissions by 2050” scenario). Projections show that this monumental goal is within reach, but more refinement in the technology via implementation is needed. Another one of the major drawbacks to this technology is that the current costs to implement the technology are quite high, deterring companies from utilizing the technology.

For this technology, there are two methods of achieving the capture of the CO₂, solid and liquid capture. For solid capture, solid sorbents such as metal–organic frameworks (MOFs), zeolites, activated carbon, silica materials, carbon nanotubes, porous organic polymers, and carbon molecular sieves are used to bind with the CO₂. The solids can then be reheated to release the CO₂ in a desired process location for an industrial process or for storage. Liquid capture utilizes solutions that CO₂ air can flow through and react with the gas to strip the CO₂ and send a pure stream of the CO₂ further through the process.

2.1.1 Carbon Engineering

As direct air capture is still a relatively new technology, many organizations are currently researching how to improve this technology. One of the leaders in this field is Carbon Engineering. Carbon Engineering was founded as a company focused on improving direct air capture and scaling up the technology to around 1 MtCO₂/yr. The research and developments that Carbon Engineering have made are leading in the field of direct air capture, and is reported in “A Process

for Capturing CO₂ from the Atmosphere”, written by David Keith, Geoffrey Homles, David St. Angelo, and Kenton Heidel. This paper was used by the 2022 Carbon Capture and Conversion Capstone group, which this paper will also be building off of, and thus the following report will utilize Carbon Engineering’s pilot plant as a basis while still providing a novel approach to the problem.

2.1.2 2022 Carbon-Neutral Production of Methanol Via DAC Capstone Group

As mentioned, the following report will build on the 2022 Carbon Capture and Conversion capstone project. The same general process and scale up design will be used, but with some key differences to make this report its own novel idea. The primary difference will be in the power island for the direct air capture portion of the plant. The previous report on this topic has black boxed this portion of their process. This report will dive into said power island by incorporating a combustion reactor to heat the calciner, but will purchase electricity for the majority of the plant. Another major difference in the process described in this report is in the calciner, making this report unique in comparison to the previous paper.

2.1.3 Existing Modeling Research

Outside of Carbon Engineering, other companies and universities around the world have contributed to the development of direct air capture. One such thesis, “Process modeling of a Direct Air Capture (DAC) system based on the Kraft process,” was written at the Politecnico di Torino (Bianchi, 2018). This report utilized ASPEN software to model the unit operations of the pilot plant data. The thesis utilized the electrolyte non-random two-liquid (NRTL) model for the liquid phase streams and the Soave-Redlich-Kwong Equation of State (SRK EoS) model for gas phase streams. Electrolyte-NRTL accounts for the ionic dissolution that occurs between solid components in the system and the water in the system, and SRK EoS describes the relationships between temperature, pressure, and volume of a gaseous component (Bianchi, 2018). These modeling choices will be used as a basis for this report, with some variations in design for different units of the process.

2.2 Methanol Synthesis Previous Work

Methanol production, unlike the novelty of direct air capture, has been a fundamental process for many years. Methanol was first isolated in 1661 by Robert Boyle, and then in 1834 Jean-Baptiste Dumas and Eugene Peligot determined its elemental composition (TheChemicalCompany 2023). Currently, the standard for methanol production is to hydrogenate synthesis gas (syngas) containing CO and H₂. However, the process in this report will utilize the DAC system to absorb CO₂, convert the CO₂ into syngas in the RWGS, and then will produce methanol via hydrogenation and distillation.

2.2.1 The CAMERE Process

The process utilized in this report is based on the CAMERE process. The CAMERE process is carbon dioxide hydrogenated to form methanol via a reverse-water-gas-shift reaction (Joo, 1999). This will be the process utilized for the most part, just with the alteration of the source of the CO₂. Straying away from a petroleum dependency for this process is vital to reducing the carbon emissions and making the process a net-zero impact.

III. DISCUSSION

3.1 Overall Design Basis

The figure below (Figure 3.1-1) demonstrates a simplified overall design basis diagram, compiling several pieces of equipment into a “direct air capture” block and several pieces of equipment into a “methanol synthesis” block. The direct air capture block (Figure 3.1-2) major equipment includes an air contactor, pellet reactor, dryer, combustion reactor, calciner, and slaker, as well as several pumps and conveyors as ancillary equipment. The methanol synthesis block (Figure 3.1-3) converts the CO₂ captured in the direct air capture block to methanol through major equipment including the reverse water gas shift reactor, CO hydrogenation reactor, and distillation column in addition to several pieces of ancillary equipment. The calciner produces 0.98 Mt-CO₂ per year which is sent to the reverse water gas shift reactor in a stream which connects the two blocks together.

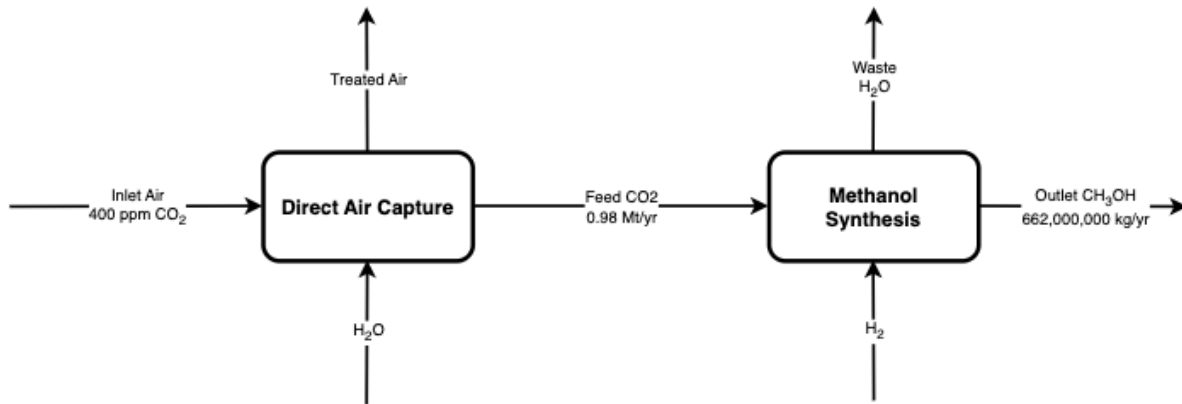

Figure 3.1-1 DAC and Methanol Synthesis Block Flow Diagram

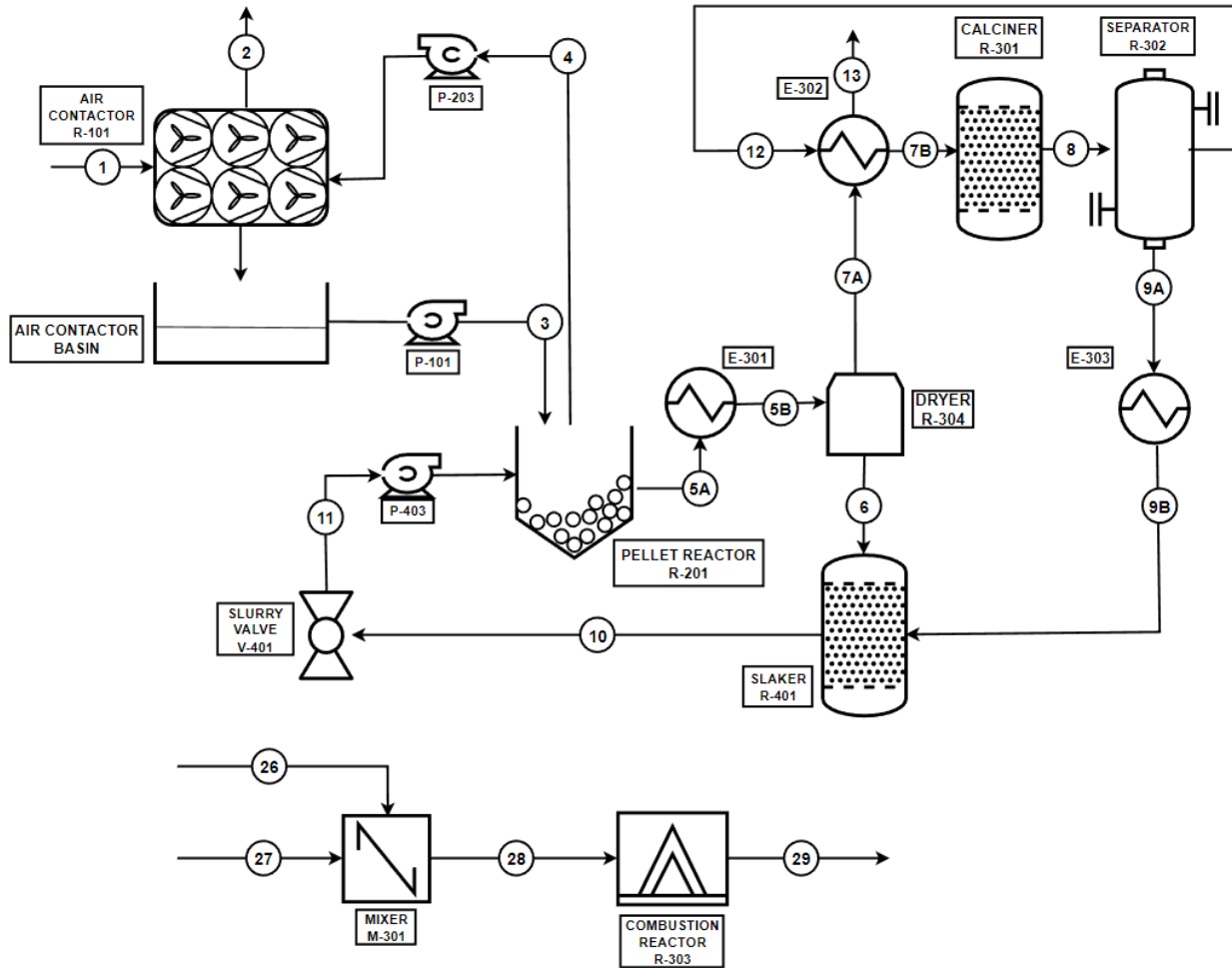

Figure 3.1-2 Direct Air Capture Process Flow Diagram

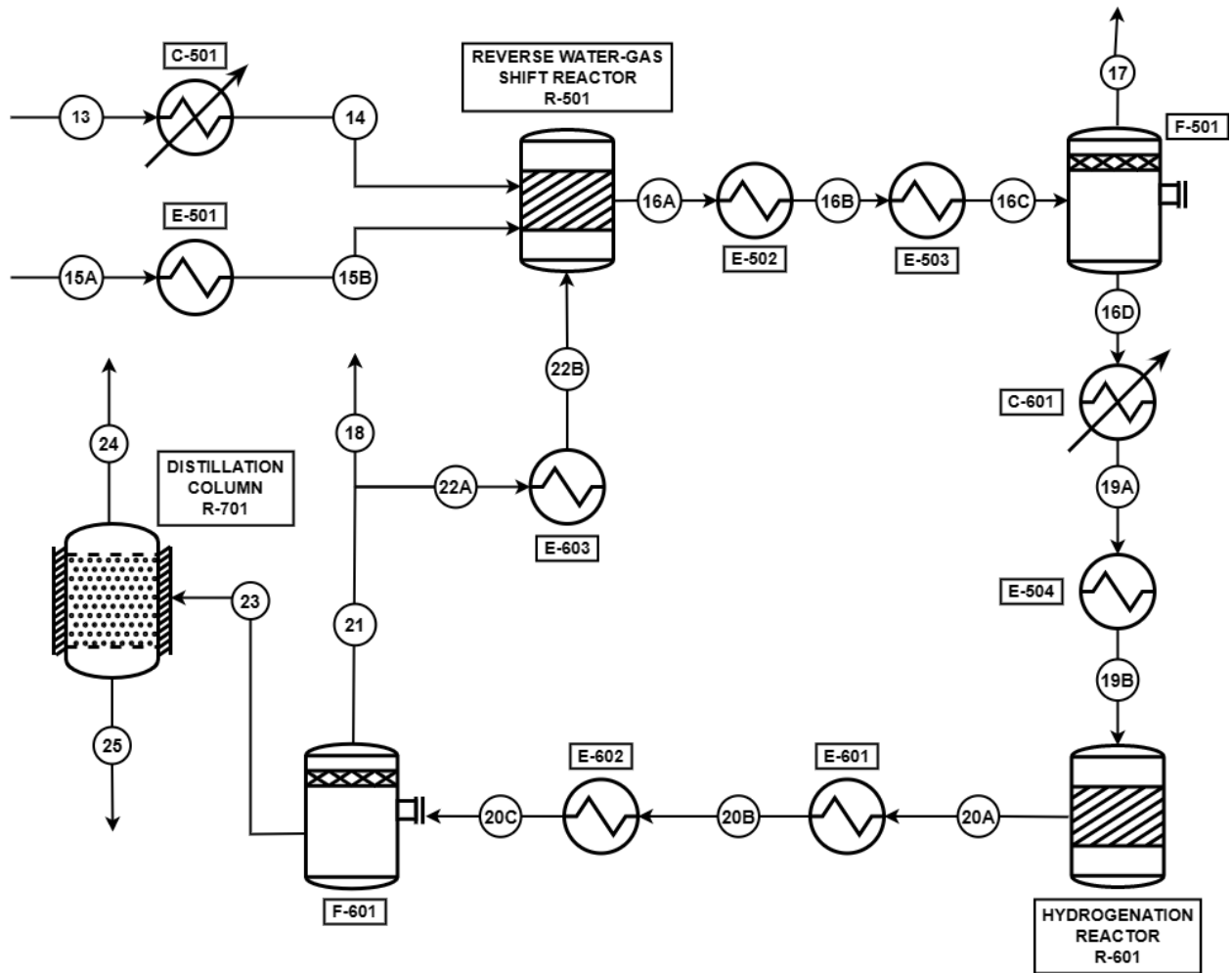

Figure 3.1-3 Methanol Synthesis Process Flow Diagram

3.1.1 Direct Air Capture Design Basis

Literature review had suggested two possible DAC processes: high temperature aqueous solution (HTAS) and low temperature solid sorbent (LTSS) systems. HTAS was chosen because this system is continuous, suitable for large scale CO₂ capture. KOH was chosen to be the sorbent since it could produce high purity streams of CO₂. In the chosen high-temperature aqueous solution based DAC, a potassium hydroxide sorbent connected to a calcium caustic loop is used to recover carbon dioxide (Keith et al., 2018). This is accomplished through the use of four major unit operations: air contactor, the pellet reactor, the slaker, and the calciner. The process is shown below in Figure 3.1.1-1.

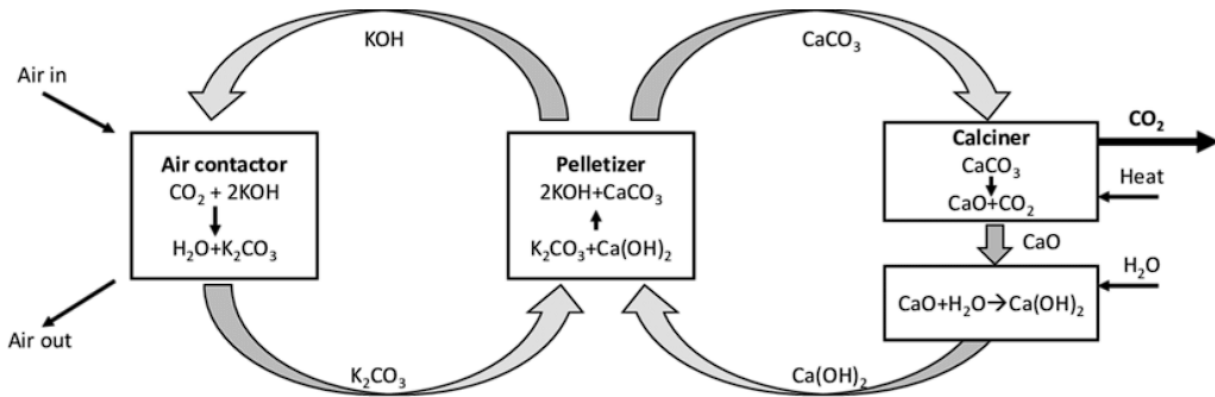
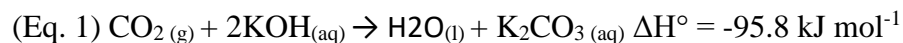
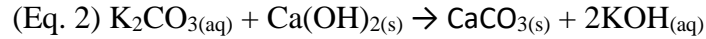

Figure 3.1.1-1 CO₂ Production Via Potassium Hydroxide Sorbent and Calcium Caustic Recovery Loop System (Keith et al., 2018)

The purpose of the first unit, the air contactor, is to draw in ambient air to be used for this process. The air contactor is designed to be a vertical tower with plastic packing, where CO₂ in air contacts with a thin film of KOH solution in a cross-flow design to chemically bind with the solution and make K₂CO₃. The previous design had provided several design parameters for the air contactor: the aqueous contact solution was specifically composed of 1.0M OH⁻, 0.5M CO₃²⁻, and 2.0M K⁺, operating at 21°C and ambient pressure, assuming an ambient CO₂ concentration of 400 ppm. The reaction is shown below:



The second unit is the pellet reactor. The reaction will take place in a fluidized bed reactor where a slurry of Ca(OH)_2 is injected into the bottom of the reaction vessel, and pellets of CaCO_3 are then formed as Ca(OH)_2 dissociates into Ca^{2+} and subsequently reacts with CO_3^{2-} . The formula for the reaction is as follows:



The pellets are sent to a calciner, where temperature is raised from 300°C to 900°C to decompose CaCO_3 pellets into CO_2 gas and CaO solid. The previous design utilized an adiabatic direct oxy-fired rotary calciner reactor that continuously injects pre-heated oxygen and methane directly with the calcium carbonate pellets. A weakness of this design is that additional unit operations (water removal system in the previous design) are required to separate CO_2 and water vapor from the combustion of methane. We propose using the heat from the heat recovery system (in the form of steam) in the power island to supply heat for the calciner. The calciner will be a dual-layer heat exchanger reactor, and the water removal system from the previous design is discarded. The reaction is shown below:

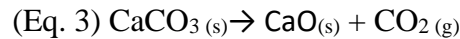

The fourth unit, the slaker, is used to regenerate the capture solution to increase the extraction of carbon dioxide. CaO pellets are sent to a slaker operating at 100°C and 10 bar, reacting with water generated by natural gas combustion from the power island to make Ca(OH)_2 . The temperature and pressure were chosen to maintain a 30% Ca(OH)_2 mixture in the slurry leaving the slaker. The reaction is shown below:

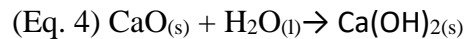

3.1.2 Methanol Synthesis Design Basis

Our goal product is methanol with a purity of 99.6% (wt. %), targeting a production rate of 412 million kg per year, which is about 7% of the annual production of methanol in the United States, at a continuous production schedule of 6000 hours per year. The scale of this project was

based on a published report by Carbon Engineering where a direct air capture plant was designed with a capacity to produce 0.98Mt of carbon dioxide per year based off of an internal pilot plant. Federal specifications for pure methanol in the United States vary depending on the grade, as specified in Ullmann's Encyclopedia of Industrial Chemistry. At a purity of 99.6%, methanol for laboratory use would qualify as "purum" quality (>99.0%), the lowest quality grade for laboratory use. Methanol for commercial use needs to be at least 99.85% methanol content and different grades (A, AA, or IMPCA) are determined by ethanol, acetone, water, and acetic acid content, among a few other specifications. To meet grade AA specifications, which is suitable for chemical applications, ethanol content is <10 mg/kg, acetone content must be <20 mg/kg, water must be <0.10 wt%, and acid must be <30 mg/kg (Ott et al., 2012). The goal for purity of the carbon dioxide stream exiting the DAC block is at least 99.8%. By-products in the CO₂ stream include oxygen, nitrogen, and trace water (Huynh et al., 2022).

In the previous design, water needed to be removed from the CO₂ stream before entering the methanol synthesis block. We will remove the water separation units, because methane combustion no longer takes place in the calciner, thus water content in the CO₂ stream is expected to be much lower. Two reactions are used to convert CO₂ into methanol. The first reaction is reverse water-gas shift (RWGS) reaction that converts CO₂ and H₂ (1:3 molar ratio) into CO and water, and a ZnO/Al₂O₃ (1:2) catalyst will be used (Joo, 2003). The resulting syngas will be sent to a condenser to separate water from CO, CO₂, and H₂. The dried CO, CO₂, and H₂ syngas (CO to CO₂ ratio 2:1) is then sent to a hydrogenation reactor to produce methanol. The 2022 report had suggested Cu/ZnO/Al₂O₃ catalyst for hydrogenation of CO to methanol. Since this catalyst is the industry standard, our design will also use this catalyst (Joo, 1999). The outlet stream from the hydrogenation reactor is separated into a gaseous CO and H₂ stream that recycles back to the RWGS reactor and a liquid methanol and water stream in a condenser. The methanol-water mixture is then sent to a distillation column for further purification.

3.2 Direct Air Capture Design

3.2.1 Air Contactor

The air contactor design does not change from the design of the previous group (Hyunh, 2022). Gas absorption occurs in a vertical cross-flow cooling tower consisting of plastic packing with an alkaline solution operating at 21°C and ambient pressure. The flow of the aqueous solution is adjusted to avoid a build up of air particulates. “After air is drawn into the contactor and passed over a thin film of potassium hydroxide (KOH) solution, ambient carbon dioxide binds to the sorbent and forms potassium carbonate (K₂CO₃). The necessary solution used in the air contactor for an initial reaction to take place will be an aqueous solution of 1.0M OH⁻, 0.5M CO₃²⁻, and 2.0M K⁺.” (Hyunh, 2022).

Potassium hydroxide was chosen for this reaction instead of other hydroxide-based compounds due to its cost-competitive nature and reliably high purity. The primary reaction that occurs in the air contractor is as follows:

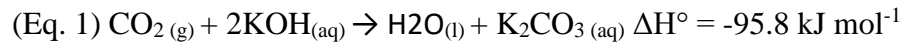

Unit Design

The air contactor unit was designed by Carbon Engineering. Large fans draw in air which is then introduced to a thin film of the alkali capture solution consisting of potassium hydroxide at the operating conditions of 21°C and 1 atm. The width of the film is approximately 50 μm and flows downward through the packing while the air flows in a cross-flow configuration. A reaction-diffusion process occurring in the film with an e-folding length of 0.3 μm limits the transport of CO₂ into the fluid. The contactor design by Carbon Engineering is based on an unit from SPX Cooling Technologies with differences in the geometry and fluid chemistry, but similarities such as the inclusion of fans, structured packing, demisters, fluid distribution systems, and fiber-reinforced plastic structural components (Keith et al., 2018). Carbon Engineering also recommended using a packing depth of 7 m and the use of cyclic-pulsing solution flow to minimize pumping energy while maintaining optimal packing wetting. The table depicts a summary of the major unit operations for this reactor gathered by Carbon Engineering:

Table 3.2.1-1: Air Contactor Process Parameters and Performance Metrics (Keith et al., 2018)

| Process Parameters | |
|--------------------------------------|--------------------------------------------|
| Mass transport coefficient | 1.3 mm/s |
| Air velocity | 1.4 m/s |
| Packing specific surface | 210 m ² /m ³ |
| Packing pressure drop | 9.7 Pa/m at 1.4 m/s |
| Max liquid flow | 4.1 L/m ² s |
| Performance Metrics | |
| Fan energy | 61 kWh/t-CO ₂ |
| Fluid pumping energy | 21 kWh/t-CO ₂ |
| Fraction of CO ₂ captured | 74.5% |
| Capture rate unit inlet area | 22 /t-CO ₂ m ² /year |

Energy Analysis

The primary chemical reaction in this reactor, as shown in Equation 1 is exothermic. Last year's Direct Air Capture Group noticed a minute temperature decrease in the outlet stream (Huynh, 2022). This same decrease appeared in the calculations for this air contactor. The endothermic behavior is likely due to the evaporation of water that comes in contact with the aqueous inlet stream. This evaporation is not modeled in the equation, but is likely the cause. The change is negligible and the unit is still run adiabatically.

Material Balance

Carbon Engineering’s pilot plant reported a carbon dioxide absorption rate of 74.5%, while last year’s Direct Air Capture group produced Aspen Plus simulations that produced 99.90% absorbency.

Modeling Via Aspen Plus

Last year’s air contactor was designed in Aspen Plus utilizing the electrolyte package with the ENRTL-RK base method to model the dissociation of compounds into their ions in solution, which is necessary for the reaction between carbon dioxide and aqueous potassium hydroxide (Huynh, 2022). The process was modeled with a Flash2 unit for understanding possible absorption at equilibrium and the results showed 99.90% of carbon dioxide reacts with potassium hydroxide.

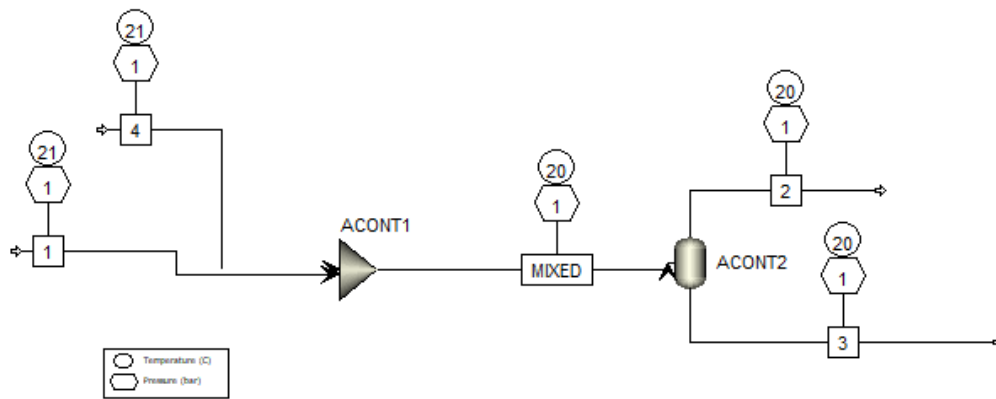

Figure 3.2.1-1 ASPEN Air Contactor Model

Table 3.2.1-2 Air Contactor ASPEN Details

| Block | Type | Temperature (°C) | Pressure (Bar) | Heat Duty (MW) |
|--------|--------|------------------|----------------|----------------|
| ACONT1 | Mixer | 20 | 1.01 | 0 |
| ACONT2 | Flash2 | 20 | 1.01 | 0 |

3.2.2 Pellet Reactor

The pellet reactor is used to form calcium carbonate pellets through a salt metathesis reaction between potassium carbonate from the air contactor and calcium hydroxide from the slaker. The desired product from this reaction is calcium carbonate, which is sent to the calciner to be decomposed. The reaction is as follows:



Unit Design

The pellet reactor was designed using the same design from the Direct Air Capture group. The reactor is an adiabatic fluidized bed crystallizer which operates at 25°C and 1 bar. A fluidized bed reactor allows the incoming aqueous potassium carbonate to react with calcium hydroxide as well as allowing calcium carbonate to react with the calcium carbonate pellets that are suspended in the system. Pellets are added at the top of the bed and sink through the reactor as they grow in size until they are discharged through the bottom through a 20 mesh shaking screen. Roughly 10% of the pellets that leave the reactor as fines must be captured by a downstream filter. The finished pellets are roughly spherical calcite crystals with a negligible porosity. This process was adapted by Carbon Engineering from water treatment technologies to allow calcium carbonate crystals to form in high ionic strength solutions. This process requires a Spiractor configuration with conical feed sections in a large concrete reactor. The pumping efficiency of 82% is based on GPSA data, while the fluidization velocity of 1 m/s is based on performance metrics from Carbon Engineering.

Energy Analysis

This reaction is slightly exothermic; however, this reactor is designed to be adiabatic and no heat is added or removed. Because the temperature change between the inlet and outlet streams is less than 3°C when modeled in Aspen Plus, energy considerations are considered to be negligible as small temperature changes such as this are considered to be inconsequential to the process.

Material Balance

To determine the mass balance, the “calcium retention” rate reported by Carbon Engineering is assumed to be equivalent to the extent of reaction over the pellet reactor system.

This is due to Carbon Engineering’s claim that the calcium retention rate is a measurement of pelletization performance (Keith et al., 2018). Through ASPEN Plus simulations, the calcium retention rate was determined to be 90%.

Modeling Via Aspen Plus

The pellet reactor was designed using the Aspen Plus electrolyte package with ENTRL-RK base method as done by the Direct Air Capture Capstone group (Huynh, 2022). The ENTRL-RK base method is used to account for the dissociation and precipitation reactions necessary for this unit’s operation (“Aspen Physical Property System,” 2001). The electrolyte package accounts for the ionic interactions for the salt metathesis reactions in the pellet reactor. Similar to last year’s design, an upstream mixer for the feed streams of pure calcium hydroxide and aqueous potassium carbonate (2.0 M K⁺) was installed before a Flash2 block to separate the products.

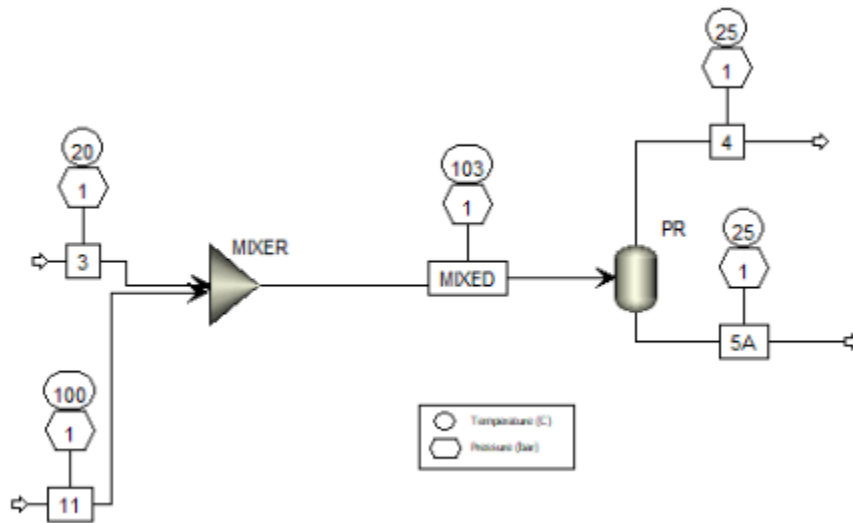

Figure 3.2.2-1 ASPEN Pellet Reactor Model

Table 3.2.2-1 Pellet Reactor ASPEN Details

| Block | Type | Temperature (°C) | Pressure (Bar) | Heat Duty (MW) |
|-------|-------|------------------|----------------|----------------|
| PRMIX | Mixer | Not specified | 1 | 0 |

| | | | | |
|-----------|--------|----|---|------|
| PR | Flash2 | 25 | 1 | -178 |
|-----------|--------|----|---|------|

3.2.3 Calciner

The calciner facilitates the decomposition of calcium carbonate pellets formed in the pellet reactor. This reaction produces calcium oxide, which is sent to the slaker, and a mixture of mostly carbon dioxide with trace carbon monoxide, oxygen, and nitrogen. The primary chemical reaction is as follows:

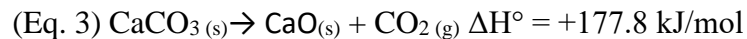

Due to the endothermic nature of the primary reaction in the calciner, calcium carbonate pellets are continuously heated to 898°C at ambient pressure (1.01 bar). These conditions were chosen as literature shows that calcium carbonate decomposition reactions typically occur between 820°C and 910°C, with a typical operation temperature being 898°C (Fedunik-Hofman, 2019).

Unit Design

The calciner is designed to be a dual-layered rotary indirect-fired calciner. The reactor will be adiabatic since high temperatures drive the dissociation of calcium carbonate and is able to remain controlled within the unit. Calciners are commonly used to decompose calcium carbonate in a carbonate looping process for CO₂ capture, particularly in lime and cement plants. The most direct way to heat the calciner is through direct-firing where methane and oxygen are injected into the reactor. However, the combustion reaction of methane would require technical oxygen and generate large amounts of water, in addition to soot and impurities (sulfur, ash). Indirect heating of the calciner can be achieved through metallic walls, by solids circulation, or via heat pipes. Heat pipes were chosen since they offer excellent heat transfer performance and the feasibility of the indirect heating carbonate looping process using heat pipes has been demonstrated in a 300 kWth pilot plant during more than 300 hours of stable CO₂ capture at various operating points (Ströhle, 2021). The primary chemical reaction for methane combustion is as follows:

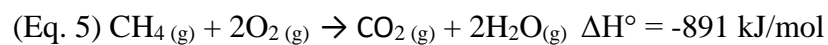

This highly exothermic reaction will take place in a separate combustion reactor where ambient air and methane are fed to the reactor, exhaust containing CO₂, H₂O, N₂, and trace impurities exits the reactor and is fed back to the direct air contactor. For simplicity in material balance calculations, the CO₂ molar flow rate exiting the combustion reactor is assumed to be 10% of the CO₂ captured by the air contactor, however the actual amount of CO₂ being produced to heat the calciner is much higher. Aspen Plus modeling determined the optimal flow rate for methane into the combustion reactor is 2150 kmol/hr of 100% CH₄, which maximizes CO₂ output from the calciner in stream 12 at 3972 kmol/hr (in addition to 4033 kmol/hr of CaO, 31 kmol/hr of O₂, and 61 kmol/hr of CO). These values are adjusted in Table 3.2.3-1 to account for Carbon Engineering's reported 98% conversion of CaCO₃ to CO₂ in their pilot plant, measured using chemical analysis and X-ray diffraction analysis on discharged pellets. CO₂ in the exhaust from the combustion reactor is 2159 kmol/hr which is 55% of the CO₂ exiting the calciner. Heat pipes will transport heat into the outer chamber of the calciner to heat the unit to 898°C. The heat of the flue gas leaving the calciner is used to pre-heat the raw material. In future improvements, the heat of the remaining flue gases and the heat from the exhaust of the calciner could be extracted in heat recovery steam generators for power generation as well as for heating the dryer.

Energy Analysis

Heat is supplied to the calciner via external combustion and energy requirements of this endothermic reaction can be evaluated by the heat duty found via Aspen Plus modeling. The heat duty of the calciner was found to be 303.3 MW. The heat duty of the dryer was found to be 155.3 MW, the heat needs of which still need to be integrated. Options include utilizing the heat from the exhaust leaving the combustion reactor, finding heat elsewhere in the system, or feeding more methane into combustion and pipe heat to the dryer.

Material Balances

To determine material balances on this system, the extent of reaction of 0.98 reported by Carbon Engineering's DAC pilot plant is used since this study collected real-world data and determined the extent of reaction from experimentation (Keith et al., 2018).

Modeling Via Aspen Plus

As previously discussed, the calciner unit will be modeled as an adiabatic indirect-fired rotary calciner (R-301) with a desired operating temperature and pressure of 898°C and 1.01 bar, respectively. In addition to heat pipes from the combustion reactor (R-303) which provide energy necessary to achieve extreme temperatures, feed streams to the calciner include calcium carbonate (CaCO₃) from the pellet reactor (R-201). Prior to being fed to the calciner, the calcium carbonate exits the pellet reactor at 25°C and passes through one heat exchanger (E-301), then a dryer (R-304) which operates at 105°C to evaporate the water, and then a second heat exchanger which uses the out gases from the calciner to further pre-heat the CaCO₃. The CaCO₃ inlet flow rate to the calciner was calculated based on desired methanol production and related carbon dioxide production. The temperature of this flow was modeled to be 321°C and will be achieved via heat exchangers discussed in the following section. The inlet flow rate for methane into the combustion reactor was determined through modeling of the calciner to have an outlet stream temperature of 898°C and the flow of air into the combustion reactor was fed at approximately 10% excess. It is assumed that methane and air streams are at an ambient temperature of 21°C.

In Aspen Plus, the calciner unit was modeled using the RK-SOAVE property method with a RGibbs reactor as this model provided the most accurate representation based on its ability to predict mass and energy balances via thermodynamic databases. This allows the user to input the desired operating conditions and Aspen provides an analysis of the products given the reaction reaches equilibrium and results in the full conversion of CaCO₃. The modeled product flow rates were adjusted to replicate the conversion given from Carbon Engineering's data as seen in Table 3.2.3-1 below. It was assumed that the combustion of methane goes to completion, whereas the decomposition of CaCO₃ has a 98% conversion. The trace amounts of carbon monoxide produced from incomplete combustion of methane was 61.3 kmol/hr and it still needs to be evaluated whether this amount will alter downstream unit designs.

Table 3.2.3-1 Outlet Flow Rate from Calciner

| Component | Modeled Flow Rate (kmol/hr) | Adjusted Flow Rate* (kmol/hr) |
|-------------------|----------------------------------------|------------------------------------------|
| CaCO ₃ | 0 | 80.67 |

| | | |
|-----------------|--------|---------|
| CO ₂ | 3972.0 | 3891.4 |
| CaO | 4033.4 | 3952.70 |
| CO | 61.3 | 61.3 |
| O ₂ | 30.7 | 30.7 |

*assumes 98% conversion of CaCO₃

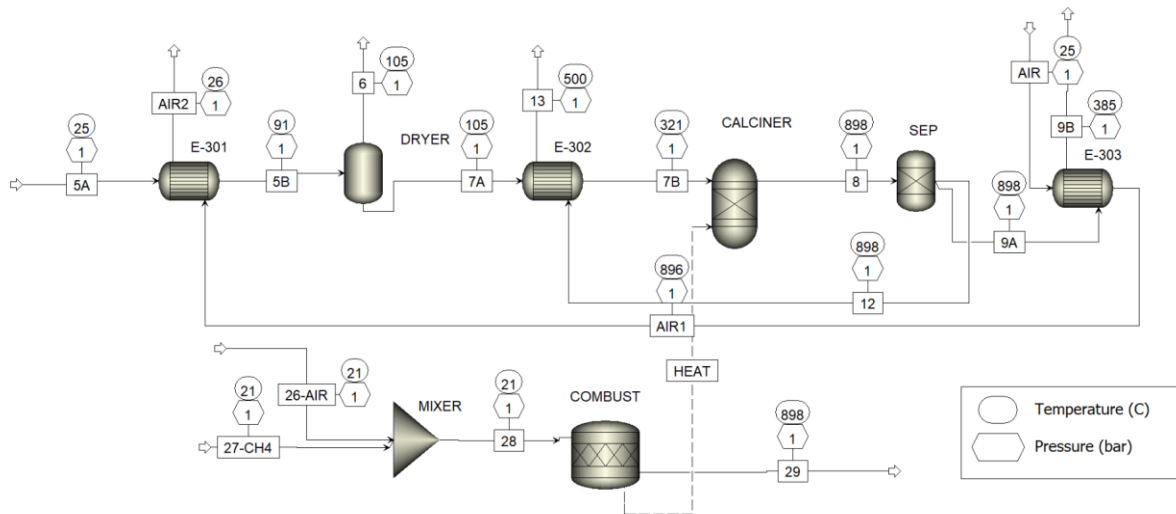

Figure 3.2.3-1 Calciner ASPEN Model

Table 3.2.3-2 Calciner ASPEN Details

| Block | Type | Temperature (°C) | Pressure (Bar) | Heat Duty (MW) | Extent of Reaction |
|-------------------------|--------|------------------|----------------|----------------|--------------------|
| CALCINER (R-301) | RGibbs | 898 | 1.01 | 271.7 | 0.98 |
| SEP (R-302) | Sep | 898 | 1.01 | - | - |
| COMBUST (R-303) | RStoic | 898 | 1.01 | -271.7 | 1.00 |
| DRYER (R-304) | Flash2 | 105 | 1.01 | 163.6 | - |

3.2.4 Direct Air Capture Heat Exchanger Design

The direct air capture system requires considerable design in regards to heat integration. The combustor and calciner operate at a higher temperature than any other unit in this system or in the methanol synthesis system. During the start-up phase, the calciner (R-301) will be entirely heated by combustion of methane in the combustion reactor (R-303) until hot CaO and exhaust gases exit the system and start cycling through the heat exchangers (E-302 and E-303) to heat the incoming feed to the calciner. One heat exchanger (E-303) uses an industrial dry air stream to absorb heat from the hot CaO solids exiting the calciner and another heat exchanger (E-301) uses that hot air stream to increase the temperature of the wet CaCO₃ exiting the pellet reactor. This heat exchanger system avoids the utilization of a solid-solid heat exchanger by using an intermediate fluid (air) to transfer heat from one solid stream to another.

Solid-solid heat exchangers are not as common in the chemical industry as other types of heat exchangers, such as shell-and-tube or plate-and-frame heat exchangers. This is because solid materials are generally poor conductors of heat and have low thermal conductivity. Therefore, it can be challenging to design solid-solid heat exchangers that provide efficient heat transfer. Indirect heat transfer through a heat transfer medium is used to circumvent this issue by using a heat transfer medium, such as a metal wall or a heat transfer fluid like water, steam, thermal oil, air or even supercritical carbon dioxide (sCO₂). This can be achieved using moving-bed heat exchangers (MBHE). Indirect bulk-solids heat exchangers typically are configured for counterflow heat transfer to maximize heat transfer effectiveness (Marinitsch, 2021).

Modeling via Aspen

Three countercurrent heat exchangers modeled by shortcut HEATX blocks are used to heat the inlet stream of CaCO₃ to the calciner. The HeatX model was chosen as it models a two stream, shell-and-tube heat exchanger and can perform simplified rating calculations (heat and material balance) if the exchanger geometry is unknown. The *Shortcut* calculation mode was chosen as this mode can perform the necessary material and energy balances without knowledge of the geometry of the exchanger (“Heat Exchangers in Aspen Plus,” n.d.).

Heat Exchanger E-301

The first heat exchanger (E-301) is a gas-solid fluidized bed heat exchanger modeled using the shell and tube shortcut method. It utilizes 4000 kmol/hr of industrial dry air at 895°C to heat 4033 kmol/hr of CaCO₃ (with 13445 kmol/hr of water) at 25°C (1.01 bar) to 91°C. The hot air stream exits at 25°C. The hot industrial air stream is heated through the heat exchanger E-303.

Heat Exchanger E-302

The second heat exchanger (E-302) uses the outlet gas stream of the calciner which flows at 4033 kmol/hr at 898°C (1.01 bar) to raise the temperature of the CaCO₃ to 98°C before it enters the dryer. E-302 heats the dry CaCO₃ stream to 231°C using the outlet CO₂ stream from the calciner, which exits the heat exchanger at 500°C before being sent to the RWGS reactor. Rotary kilns are commonly used for solid-to-gas heat exchange in cement manufacturing and other high-temperature applications, and fluidized bed heat exchangers are efficient, as well, for direct contact applications.

Heat Exchanger E-303

The third heat exchanger (E-303) is a fluidized bed heat exchanger which utilizes the same industrial dry air stream as E-301. E-303 takes the hot solid CaO stream exiting the calciner and lowers the temperature to 385°C before sending the CaO to the slaker. Solid-solid heat exchangers are not common but a means for such heat exchange is to use an intermediate circulating inert fluid medium, in this case, the air stream, that is heated by the "hot" reactive stream of solids. A system would consist of two direct-contact countercurrent heat exchangers or fluidized bed heat exchanger, one for each of the reactive solid streams, with the fluid heat transfer medium circulating between them (Curl, 1980).

Table 3.2.4-1 Calciner Heat Exchanger ASPEN Details

| | Heat Duty (MW) | Area (m²) |
|--------------|-----------------------|-----------------------------|
| E-301 | 30.4 | 297.7 |
| E-302 | 23.9 | 58.6 |

| | | |
|--------------|-------------|--------------|
| E-303 | 30.5 | 541.0 |
|--------------|-------------|--------------|

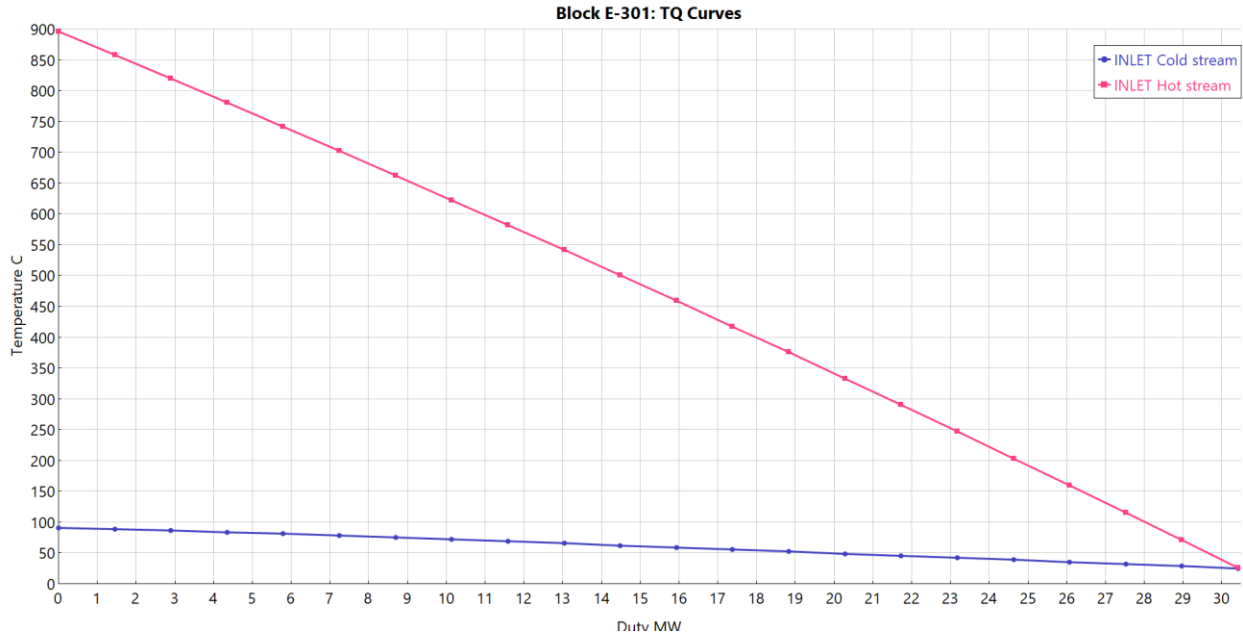

Figure 3.2.4-2 Heat Exchanger TQ Graph (E-301)

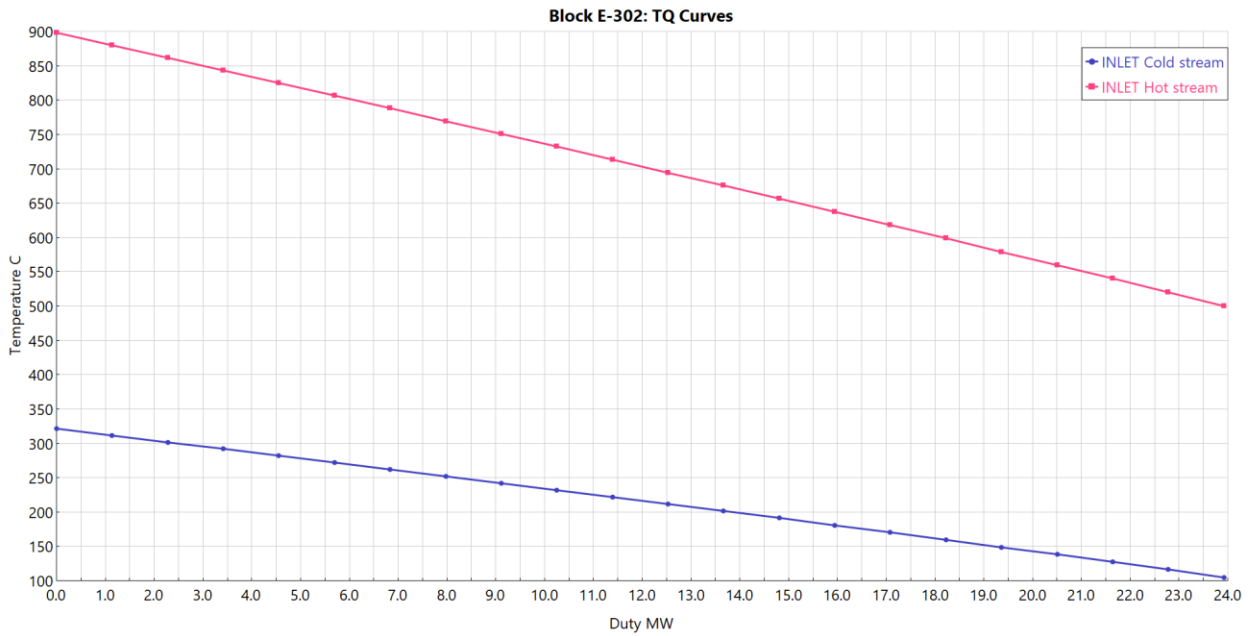

Figure 3.2.4-3 Heat Exchanger TQ Curves (E-302)

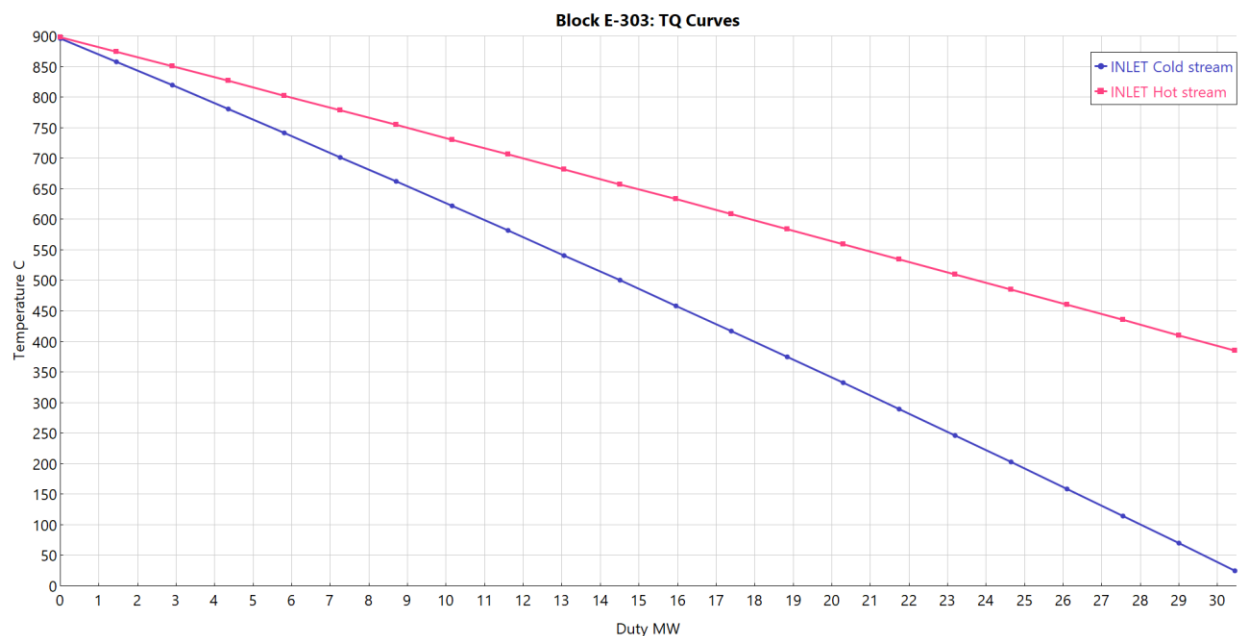
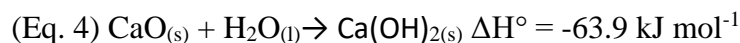

Figure 3.2.4-4 Heat Exchanger TQ Curves (E-303)

3.2.5 Slaker

The slaker unit hydrates the calcium oxide formed in the calciner. This regenerative process created calcium hydroxide that is used in the pellet reactor to form calcium carbonate. The chemical reaction in this unit is as follows:



Unit Design

The slaker is a refractory lined bubbling/ turbulent fluid bed that is fluidized by recirculating steam flow as described by Carbon Engineering (Keith et al., 2018). This unit receives hot CaO at 300°C from the calciner and CaCO₃ pellets at ambient temperature from washing. The fluidization velocity is 1 m/s, at which quicklime (CaO) particles are transported and slaked to form Ca(OH)₂. Small CaO particles are captured and recirculated by a primary cyclone and loop seal. The finer particles bypass the cyclone and are primarily captured in a dust collector. The outgoing stream consists of hydrated lime at 100°C and 10 bar, which is then dried and warmed to produce the pellets. The heat used to dry the pellets originates from the exothermic slaking reaction and the reactor is cooled to its operating temperature by cooling water. The dry

pellets are then fed into the top of the calciner through a closed-loop pneumatic conveyor driven by recirculating CO₂.

Energy Analysis

The steam slaking process that occurs in this unit is exothermic with a heat duty of approximately -246 MW according to Aspen simulations. The slaker is operated using the heat from the pellets arriving from the calciner and cooling steam to operate at the desired temperature. The slaker was run at this temperature and pressure it to maintain 30 mole percent of CaCO₃ in the outlet stream.

Modeling Via Aspen Plus

Last year's Direct Air Capture group modeled a simplified slaker unit in Aspen Plus using an RStoic unit with the RK-SOAVE base method. The RStoic unit allows for the simulation of the chemical reaction under specific conditions with a specified extent of reaction, which allows for the energy evaluations to be representative of the material balance..

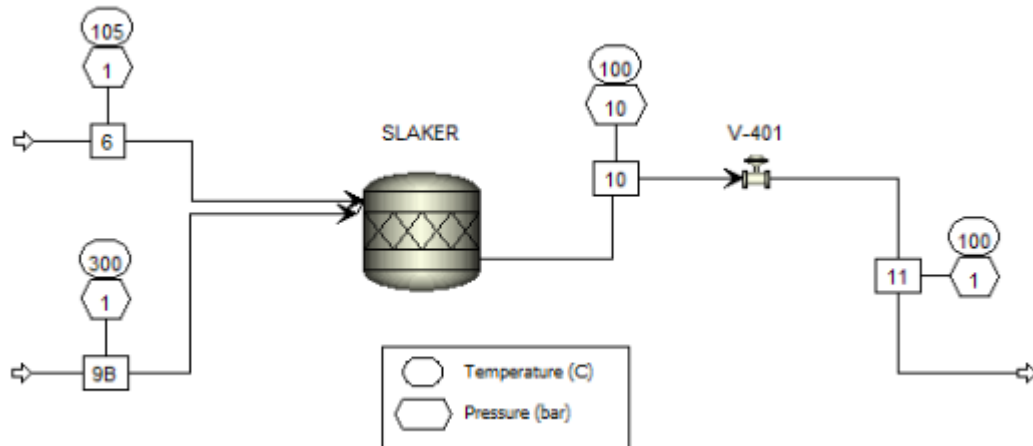

Figure 3.2.5-1 ASPEN Slaker Model

Table 3.2.5-1 Slaker ASPEN Details

| Block | Type | Temperature (°C) | Pressure (Bar) | Heat Duty (MW) | Extent of Reaction |
|---------------|-------------|-------------------------|-----------------------|-----------------------|---------------------------|
| SLAKER | RStoic | 100 | 10 | -246 | 0.85 |

Slurry Valve

Last year's group reported on a slurry mixer which allowed for water to be mixed with the lime slurry coming out of the slaker and into the pellet reactor. The purpose of the slurry mixer was to create a slurry of calcium hydroxide that will be injected into the bottom of the pellet reactor to facilitate calcium carbonate pellet generation. This mixture, also referred to as hydrated lime, contains calcium hydroxide suspended in water. Like last year's group, this mixture will contain 30 wt% calcium hydroxide in water. Slurry mixers are commonly used in water treatment processes where hydrated lime is used to treat contaminated water (Hyunh, 2022). Unlike last year's group, the optimal weight percentage was able to be achieved through the slaker itself at an operating pressure of 10 bar. Therefore, only a valve was needed to change the pressure to 1 bar to send the slurry into the pellet reactor.

Using ASPEN calculations, the valve will be a 2-in, Metal Seated Full Port ball valve. This size and style allows for a 70% valve opening at the maximum flow rate. Industry standards suggest an opening percentage between 60-80% at maximum flow rate for optimal control of flow. The valve flow coefficient reported by ASPEN for this valve is 68.32 with a pressure drop of 9 bar and a pressure recovery factor of 0.74.

3.2.6 Pump and Conveyor Design

Pumps

In the DAC process, liquids like potassium hydroxide, potassium carbonate, and calcium hydroxide slurry need to be moved between different unit operations. To achieve this, three pumps were created for the process: P-101, P-203, and P-403. P-101 transfers the potassium carbonate capture solution from the air contactor to the pellet reactor. The slurry mixer's output is carried to the pellet reactor using P-403. P-203 moves the regenerative solution from the pellet reactor to the

air contactor to supply potassium hydroxide. The continuous flow of liquid between the air contactor and pellet reactor enables the constant removal of carbon from the ambient air.

The pumps will be centrifugal pumps since they are generally standard in industry applications and can handle flows from 1 to 1000 L/s and up to 150 m of gravity head. The pump itself will be assumed to be 70% mechanically efficient and the electrical driver assumed to be 90% efficient, resulting in the tabulated electrical draw. Frictional losses within the pipes and for each control valve necessary for centrifugal pumps are assumed to be 0.5 atm each for a total of 1 atm total frictional losses for each pump. To supply the air contactor, pump, P-203, will transport the fluid 20 meters vertically, Carbon Engineering’s reported height of their air contactor system (Keith et al., 2018). P-403 will transport the slurry 7 meters vertically (height of the reactor according to Huynh et al.) to ensure that the slurry reaches the highest point of the pellet reactor (Huynh et al., 2022).

Table 3.2.6-1 DAC Pump Operating Conditions

| Pump | Total Frictional Losses (kPa) | Gravity Head (kPa) | Differential Pressure (kPa) | Hydraulic Power (kW) | Electric Draw (kW) |
|--------------|--------------------------------------|---------------------------|------------------------------------|-----------------------------|---------------------------|
| P-101 | 101.3 | 0 | 101.3 | 131.6 | 188.0 |
| P-203 | 101.3 | 233.2 | 369.2 | 278.7 | 398.1 |
| P-403 | 101.3 | 98851.9 | 98953.2 | 11082.8 | 15832.5 |

Conveyors

In the DAC process, a significant amount of the material that needs to be transferred between units exists in a solid phase. These materials consist of calcium carbonate pellets, CaO generated in the calciner, and Ca(OH)₂ formed in the Slaker. As a result, conveyor systems are required rather than pumps. Closed-loop pneumatic conveyors were selected for this process as they are a standard transport method for solids in the industry. Moreover, since several streams are at elevated temperatures, the pneumatic component can help with cooling if required.

To limit the scope of this report, the design of the pneumatic conveyor is restricted. The report assumes that all conveyors will have a width of 1 meter and length of 50 meters to enable

sizing and economic evaluations based on published correlations. Each of the seven necessary conveyors and their purpose are provided in the table below.

Table 3.2.6-2 DAC Conveyor Descriptions

| Conveyor ID | Stream # | Purpose |
|--------------------|-----------------|-------------------------------------------------------------------------------------------|
| P-201 | 5A | Transport CaCO ₃ pellets from Pellet Reactor (R-201) to Heat Exchanger (E-301) |
| P-202 | 5B | Transport CaCO ₃ pellets from E-301 to Dryer (R-304) |
| P-301 | 7A | Transport CaCO ₃ pellets from Dryer (R-304) to E-302 |
| P-302 | 7B | Transport CaCO ₃ pellets from E-302 to Calciner (R-301) |
| P-303 | 9A | Transport CaO from Calciner (R-301) to E-303 |
| P-401 | 9B | Transport CaO from E-303 to Slaker (R-401) |
| P-402 | 10 | Transport Ca(OH) ₂ from Slaker (R-401) to Slurry Valve (V-401) |

3.3 Methanol Synthesis Design

3.3.1 Reverse Water-Gas Shift Reactor System

The reverse water gas shift (RWGS) reactor carries out one of the two major reactions in the CAMERE (carbon dioxide hydrogenation to form methanol via a reverse water-gas-shift reaction) process: the catalytic conversion of carbon dioxide to carbon monoxide. An inlet stream of carbon dioxide from the direct air capture process and a stream of hydrogen gas purchased from the Blue Hydrogen Capstone Group will react as shown:

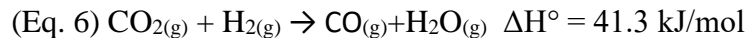

Unit Design

A packed bed reactor that contains smaller individual reactor tubes will be used. It converts the carbon dioxide from the calciner into a mixture of carbon dioxide and carbon monoxide. Literature has suggested that a mixture of carbon monoxide and carbon dioxide increases the

methanol yield in the hydrogenation reactor by chemically removing water on the catalyst surface. The operating conditions remained the same as the 2022 design: 500°C, 10.1 bar, a 61.2% conversion from carbon dioxide to carbon monoxide. These conditions are based on pilot plant data and modeling data from the Korean Institute of Science and Technology (Joo & Jung, 1999).

Catalyst

A 1:2 ZnO/Al₂O₃ catalyst is used for this reaction because of its durability. This catalyst is expected to be active for 2,000 hours (Joo & Jung, 2003). The amount of catalyst required is determined by the gas hourly space velocity (GHSV):

$$(Eq. 7.1) \quad GHSV = \frac{V_o}{M_c}$$

$$(Eq. 7.2) \quad 150000 \frac{mL}{gcat} * hr = \frac{1.279 \times 10^{11} \frac{mL}{hr}}{M_c}$$

$$(Eq. 7.3) \quad M_c = 865 \text{ kg}$$

where V_o is the exhaust flow (mL/hr), M_c is the mass of catalyst (g). GHSV = 150,000 mL/gcat*hr from the 2022 design, $V_o = 1.297 \times 10^{11}$ mL/hr from ASPEN simulation. A total of 865 kilograms of catalyst are required.

Energy Analysis

ASPEN Plus is used to simulate the RWGS reactor. The heat duty is estimated by an RGibbs reactor with RK-ASPEN method. The inlet carbon dioxide stream at 500°C will be compressed from 1 bar to 10 bar by a series of compressors and coolers. The inlet hydrogen stream at 10 bar will be heated from 30°C to 150°C by saturated steam generated at the RWGS condenser. The inlet recycle stream will be heated from 35°C to 150°C also by saturated steam generated at the RWGS condenser. ASPEN Simulation suggests 60.32 MW of heat are required to sustain this reactor.

This reactor will be heated by a fire heater, and the heat transfer area is calculated by the following equation:

$$(Eq. 8) \quad A = \frac{Q}{f} = \frac{60.32 \times 10^6 \text{ W}}{50000 \frac{W}{m^2}} = 1207 \text{ m}^2$$

where A is the total heat transfer area (m²), Q is the heat duty (W), f is the convection rate (W/m²). According to literature, the total surface flux of a compartment fire could reach 200,000 W/m²,

with convection accounting for 25% of the total flux (Veloo & Quintiere, 2013). Therefore, the convection rate of a fire heater is estimated to be 50,000 W/m². The total area needed to conduct 60.32 MW of heat at this convection rate is 1207 m². This area is then used to determine the dimensions of the individual reactor tubes and the number of tubes needed:

$$\text{(Eq. 9) } A = n \times \pi DL$$

where n is the number of reactor tubes needed, D, L are the tube diameter and length. Assume a tube diameter of 0.2 m and a length of 4 m. These tube dimensions require a total of 481 tubes to achieve the desired heat transfer area. The total volume of all reactor tubes is 61 m³.

Residence Time

The residence time of the reactor is calculated by the following equation:

$$\text{(Eq. 10) } \tau = \frac{V}{v} = \frac{61 \text{ m}^3}{35.873 \frac{\text{m}^3}{\text{s}}} = 1.68 \text{ s}$$

where τ is the residence time (s), V is the total tube volume (m³), and v is the volumetric flow rate (m³/s).

Pressure Drop

The pressure drop through the reactor is calculated by the Ergun equation:

$$\text{(Eq. 11) } \Delta P = \frac{150\mu L}{Dp^2} \frac{(1-\epsilon)^2}{\epsilon^3} vS + \frac{1.75\rho L}{Dp} \frac{(1-\epsilon)}{\epsilon^3} vS^2$$

where ΔP is the pressure drop (Pa), L is the tube length (m), μ is fluid viscosity (N*s/m²), Dp is the diameter of the packing (m), ϵ is the porosity, ρ is fluid density (kg/m³), vs is the fluid superficial velocity (m/s). From the 2022 design, Dp, ϵ , are 0.025 m, 0.75. From ASPEN simulation, ρ , μ , are 1.99 kg/m³, 2.92*10⁻⁵ N*s/m². vs is calculated by dividing the volumetric flow rate by the total cross-section area:

$$v_s = \frac{35.873 \frac{m^3}{s}}{100 * \pi * (0.1m)^2} = 2.38 \frac{m}{s}$$

The pressure drop calculated by the Ergun Equation is then 0.019 bar.

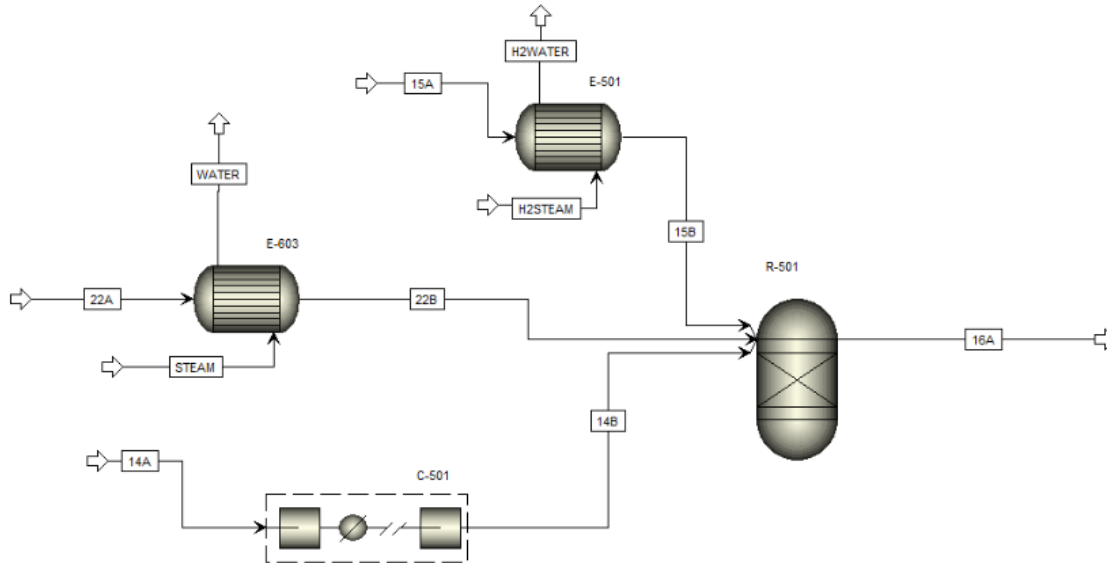

Figure 3.3.1-1 ASPEN Reverse Water-Gas Shift Reactor Model

Table 3.3.1-1 RWGS Reactor

| Block | Type | Temperature (°C) | Pressure (Bar) | Heat Duty (MW) | Extent of Reaction |
|--------------|--------|------------------|----------------|----------------|--------------------|
| R-501 | RGibbs | 500 | 10.1 | 60.32 | 0.612 |

Auxiliary Equipment

The purpose of the utilities around the RWGS reactor are to adjust the temperature and pressure of the inlet streams to closely match the operating conditions of the RWGS reactor, therefore reducing the heat duty of the reactor.

The CO₂ feed from the calciner is originally at 500°C and 1 bar. Multistage compression with interstage heat exchangers is used to increase the pressure to 10.1 bar. The initial temperature of the CO₂ feed is too high, therefore compressing the hot gas in a single stage results in a massive

heat duty. The multistage compression system consists of two compressors and two coolers, modeled by MCompr in ASPEN. The first compressor increases the pressure from 1 bar to 3.2 bar, and the second compressor increases the pressure from 3.2 bar to 10.1 bar. Compression at the first stage results in a temperature increase from 500°C to 719°C, the interstage cooler reduces the temperature down to 150°C, releasing 31.3 MW of reusable energy. Compression at the second stage results in a temperature increase from 150°C to 294°C, 11.3 MW of energy input by a heater is required to increase the temperature to 500°C. The work done by the two compressors are 12.8 MW and 7.1 MW.

The inlet H₂ stream is originally at 30°C and 10 bar. A shell and tube heat exchanger is used to preheat the H₂ stream to 153°C, and this block is modeled by HeatX in ASPEN (shortcut method). The heat source is saturated steam at 153°C and 5 bar generated at the RWGS condenser system, and a flow rate of 1050 kmol/hr is required to provide the heat. The heat duty of this heat exchanger is 11.6 MW, and the required heat exchanging area is 503 m².

The recycle stream is originally at 35°C and 8 bar. A shell and tube heat exchanger is used to preheat the recycling stream to 151°C. This block is also modeled by a HeatX block in ASPEN (shortcut method). The heat source is the same as that for the H₂ heater, requiring a flow rate of 400 kmol/hr. The heat duty of this heat exchanger is 4.4 MW, and the required heat exchanging area is 190 m².

3.3.2 RWGS Condenser System Design

Unit Design

The RWGS condenser system consists of two heat exchangers and a flash column placed in series. The gaseous reaction mixture passes through the heat exchanger to generate steam for other heating purposes, then the flash drum separates the reaction mixture into a liquid and a vapor stream. The target of the RWGS condenser system is to remove 96% of the water. The inlet stream to the first heat exchanger is set at 500°C and 9.12 bar, close to the operating temperature and pressure of the RWGS reactor. Water at 30°C and 5 bar is used as coolant, and the resulting saturated steam is at 162°C and 5 bar. The inlet is cooled to 146°C before entering the second heat

exchanger. Water at 30°C and 4 bar is used as coolant, and the resulting saturated steam is at 143°C and 4 bar. The outlet from the second heat exchanger is set at 35°C, same as the flash drum.

Energy Balance

A baseline heat transfer area and heat duty (862 m², 64.7 MW) are first calculated by using the shortcut feature in the HeatX block, then an initial shell and tube model is generated using the exchanger design and rating (EDR) feature. The geometry is optimized by varying the number of tubes, baffle type, and other parameters to match the baseline parameters and minimize tube vibration. Even though ASPEN still gives vibration warnings, the thermal results are valid. The optimal heat duty and heat transfer area are 52.4 MW and 892 m². ASPEN calculation suggests 2,460 carbon steel tubes (in 30-triangular pattern) that are 4.95 m long, 0.02 m in diameter are needed.

Material Balance

In the RWGS reactor, each mole of carbon monoxide generated corresponds to a mole of water generated. The purpose of the RWGS condenser system is to condense water before the reaction mixture enters the hydrogenation reactor, since literature suggests the activity of Cu/ZnO/Al₂O₃ catalyst is suppressed by the presence of water. Material balance indicates the condensed water from the RWGS condenser carries away approximately 0.4% of total methanol produced. Losing such a small amount of methanol has no significant economic effects. This water stream will be sent to the wastewater treatment plant.

Modeling Via Aspen Plus

In ASPEN, the first heat exchanger is simulated by the HeatX model to optimize its geometry, while the second heat exchanger is simulated by the Heater model for simplicity. The RK-ASPEN method is applied to account for non-ideality. The flash drum is modeled by a Flash2 unit. The second heat exchanger will carry all the heat duty of the flash drum (flash drum will have 0 heat duty). A baseline heat transfer area and heat duty (862 m², 64.7 MW) are first calculated by using the shortcut feature in the HeatX block, then an initial shell and tube model is generated using the exchanger design and rating (EDR) feature. The geometry is optimized by varying the number of tubes, baffle type, and other parameters to match the baseline parameters and minimize

tube vibration. Even though ASPEN still gives vibration warnings, the thermal results are valid. The optimal heat duty and heat transfer area are 52.4 MW and 892 m². ASPEN calculation suggests 2,460 carbon steel tubes (in 30-triangular pattern) that are 4.95 m long, 0.02 m in diameter are needed. The optimal cooling water flow rate is 3,700 kmol/hr. Other parameters of the RWGS heat exchanger are shown below.

Table 3.3.2-1 RWGS Reactor Heat Exchanger (E-502) Parameters

| | |
|----------------------------|---------------------|
| Shell Inner Diameter (m) | 1.4 |
| Shell outer Diameter (m) | 1.462 |
| Shells in Series | 1 |
| Shells in Parallel | 1 |
| Location of Hot Fluid | Tube side |
| Baffle Spacing (m) | 0.45 |
| Baffle Cut Orientation | Vertical |
| Number of Baffles and Type | 8, triple segmental |
| Tube Passes | 1 |

The second heat exchanger has a heat duty of 48.1 MW, requiring a cooling water flow rate of 3,678 kmol/hr. Both of the vapor and liquid stream leaving the flash drum would be at 35°C and 8.1 bar. The liquid stream leaving the flash drum removes 97.1% of the inlet water.

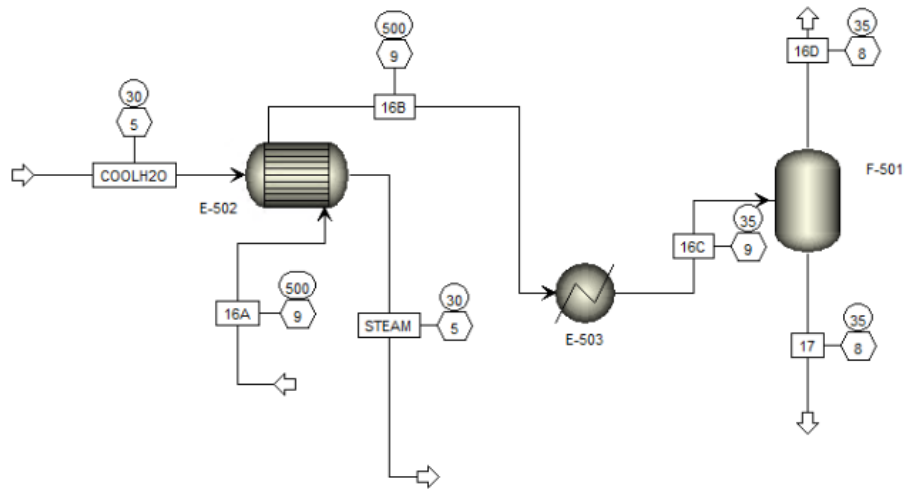

Figure 3.3.2-1 Reverse Water-Gas Shift Condenser ASPEN Model

Table 3.3.2-2 RWGS Condenser System ASPEN Details

| Block | Type | Temperature (°C) | Pressure (Bar) | Heat Duty (MW) |
|--------------|-----------------|-------------------------|-----------------------|-----------------------|
| E-502 | HeatX | 146 | 9.12 | 52.4 |
| E-503 | Heater | 35 | 8.1 | 48.1 |
| F-501 | Adiabatic Flash | 35 | 8.1 | 0 |

3.3.3 Hydrogenation Reactor System

Unit Design

The hydrogenation reaction will also occur in a heterogeneous packed bed reactor with multiple individual reactor tubes. Literature suggests the optimal operating condition for methanol production is 250°C and 30.4 bar, resulting in an 87% fractional conversion of carbon monoxide to methanol. However, carbon dioxide could also be converted into methanol. The assumption here is 87% of the inlet carbon monoxide is converted into methanol, and carbon dioxide provides the remaining carbon to reach the desired methanol production rate. Some side products include dimethyl ether (DME), formates, and ketones. The production rate of side products is unknown due to kinetic data unavailability (Ott et al., 2012). The reactions are as shown:

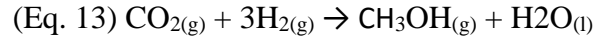
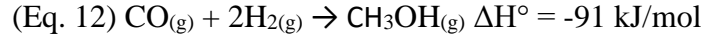

Catalyst

Cu/ZnO/Al₂O₃ catalyst is used since it is the industry standard. This catalyst is expected to be active for 1,000 hours before regeneration (Joo & Jung, 1999). The amount of catalyst required is also calculated by GHSV:

$$\text{(Eq. 7) } GHSV = \frac{V_o}{M_c}$$

Using ASPEN simulation to get a value of $V_o = 1.297 \times 10^{11}$ mL/hr, and the value of 150,000 mL/gcat*hr for GHSV from the 2022 design, a total of 1,398 kg of catalyst are needed.

Residence Time

The residence time of the reactor is calculated by the same equation used in RWGS reactor design. ASPEN simulation suggests $v = 5.514 \text{ m}^3/\text{s}$. The residence time is calculated to be 43 s.

Pressure Drop

The pressure drop through the reactor is also calculated by the Ergun equation. From the previous design, D_p , ϵ , are 0.016 m, 0.75. From ASPEN simulation, ρ , μ , are 8.18 kg/m^3 , $2 \times 10^{-5} \text{ N}\cdot\text{s/m}^2$. v_s is calculated by dividing the volumetric flow rate by the total cross-section area. The pressure drop is determined to be 0.001 bar.

Energy Analysis

The hydrogenation reaction is exothermic, heat needs to be removed from the reactor to maintain the reaction temperature. Boiling water at 198.3°C is used to cool the reactor, the resulting saturated steam exiting the heat exchanging unit will be at 15 bar according to the steam table. This steam is recycled for other heating purposes in the system. The flowrate of the coolant is calculated by the following equation:

$$\text{(Eq. 14) } Q = m \times H$$

where m is the mass flowrate of the boiling water (g/s), H is the heat of vaporization (J/g), Q is the heat duty (W). From the steam table, boiling water at 198.3°C has a heat of vaporization of 1945.2 J/g. The flowrate required is 19 kg/s. The following equation is used to calculate the total heat transfer area:

$$\text{(Eq. 15) } Q = U \times A \times \Delta T$$

where A is the total heat transfer area (m^2), Q is the heat duty (W), ΔT is the temperature difference (K) between the coolant and the reaction mixture, U is the overall heat transfer coefficient ($\text{W}/\text{m}^2 \cdot \text{K}$). From the 2022 report, U is approximately $150 \text{ W}/\text{m}^2 \cdot \text{K}$.

Modeling Via Aspen Plus

ASPEN Plus is used to simulate the RWGS reactor. The heat duty is estimated by an RGibbs reactor with RK-ASPEN method. ASPEN Simulation suggests 36.54 MW of heat needs to be removed to operate this reactor. The total heat transfer area is 4712 m^2 . Five hydrogenation reactors, each holding 1000 m^2 of heat transfer area, will be placed in series to achieve the desired heat duty. The total heat transfer area is then used to determine the dimensions of the individual reactor tubes, and the number of tubes needed:

$$\text{(Eq. 9) } A = n \times \pi DL$$

where n is the number of reactor tubes needed, D , L are the tube diameter and length. In order to use the heat transfer coefficient from the 2022 design, the dimensions of individual reactor tubes must remain the same: 0.2 m in diameter, 7 m in length. 1,072 individual reactor tubes are required to achieve the desired heat transfer area, giving a total volume of 236 m^3 .

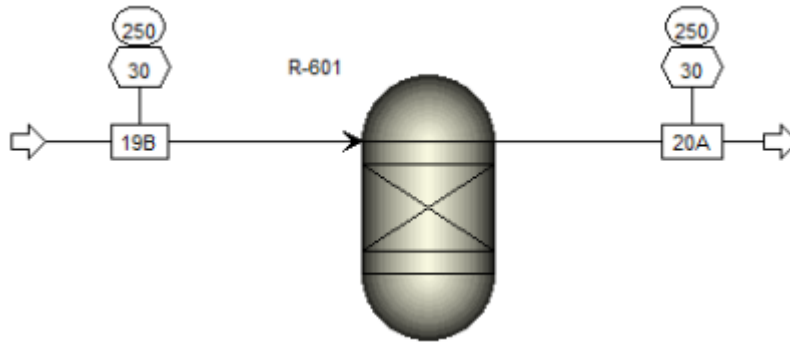

Figure 3.3.3-1 ASPEN Hydrogenation Reactor Model

Table 3.3.3-1 Hydrogenation Reactor

| Block | Type | Temperature (°C) | Pressure (Bar) | Heat Duty (MW) | Extent of Reaction |
|--------------|--------|------------------|----------------|----------------|--------------------|
| R-601 | RGibbs | 250 | 30 | -36.54 | 0.87 |

Auxiliary Equipment

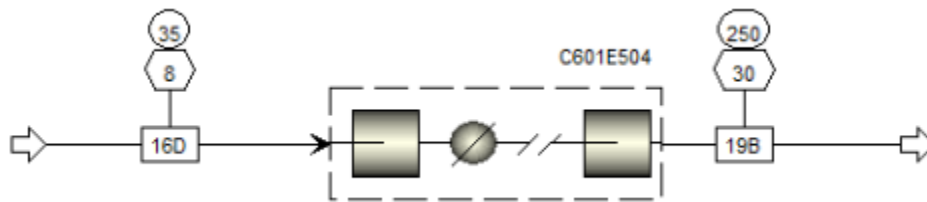

Figure 3.3.3-2 Pre-Hydrogenation Heat Exchanger Model

The hydrogenation reactor is operating at 250°C and 30 bar, but the pressure and temperature of the reaction mixture drop to 8 bar and 35°C after the RWGS condenser system. A compressor with heat exchanger is used to increase the pressure and temperature of the reaction mixture before entering the hydrogenation reactor to reduce the heat duty of the reactor. The compressor system is modeled by MCompr in ASPEN. One stage is enough to increase the pressure to 30 bar, and as a result the temperature increases to 217.5°C. The work done by the compressor is 21.7 MW. A heater provides additional 3.9 MW of energy to further increase the temperature to 250°C.

3.3.4 Hydrogenation Condenser System

Unit Design

The purpose of the methanol condenser system is to recycle the unreacted syngas and condense methanol for distillation. The hydrogenation condenser system has the same setup as the RWGS condenser system. The inlet stream to the first heat exchanger is set at 250°C and 30 bar. Water at 30°C and 5 bar is used as coolant, and the resulting saturated steam is at 166°C and 5 bar. Then the inlet is cooled to 120°C before entering the second heat exchanger. The second heat exchanger generates steam at 110°C and 1.4 bar. The outlet from the second heat exchanger is set at 35°C. The optimal cooling water flow rate is 530 kmol/hr (tube vibration eliminated). Other parameters of the first heat exchanger are shown below:

Table 3.3.4-1 Heat Exchanger (E-601) Properties

| | |
|----------------------------|---------------------|
| Shell Inner Diameter (m) | 1.9 |
| Shell outer Diameter (m) | 2.1 |
| Shells in Series | 1 |
| Shells in Parallel | 1 |
| Location of Hot Fluid | Tube side |
| Baffle Spacing (m) | 0.762 |
| Baffle Cut Orientation | Vertical |
| Number of Baffles and Type | 3, triple segmental |
| Tube Passes | 1 |

Energy Analysis

The second heat exchanger has a heat duty of 27.2 MW, requiring a cooling water flow rate of 3,678 kmol/hr.

Material Balance

Both of the vapor and liquid stream leaving the flash drum would be at 35°C and 8.1 bar. The liquid stream leaving the flash drum condenses 93.5% (2,343 kmol/hr) of the inlet methanol.

Modeling Via Aspen Plus

In ASPEN, the first heat exchanger is simulated by the HeatX model to optimize its geometry, while the second heat exchanger is simulated by the Heater model for simplicity. The RK-ASPEN method is applied to account for non-ideality. The geometry and dimensions of the first heat exchanger is optimized with the same method. The baseline heat transfer area and heat duty are 119 m² and 10.7 MW, while the optima are 109 m² and 7.6 MW. ASPEN calculation suggested 600 carbon steel tubes (in 30-triangular pattern) that are 3.65 m long, 0.02 m in diameter are needed.

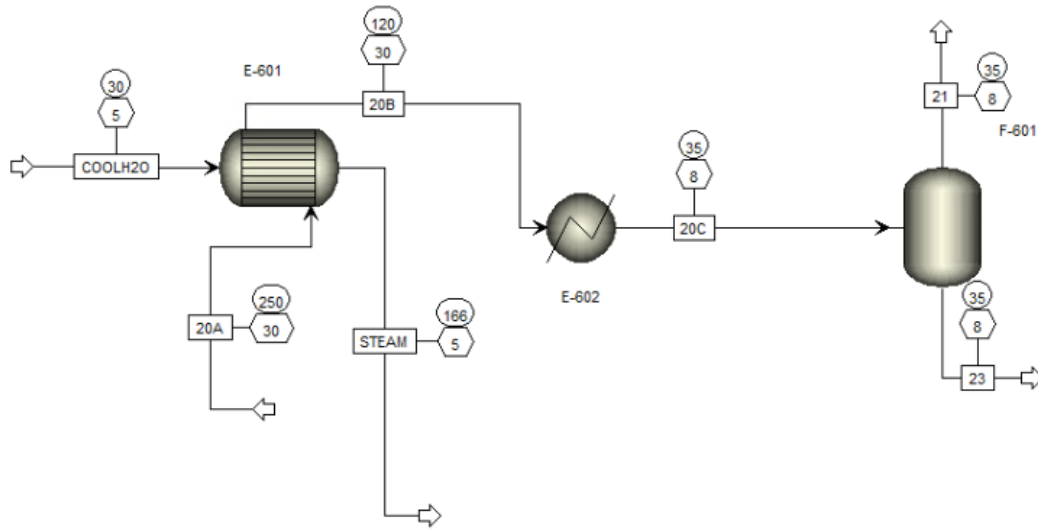

Figure 3.3.4-1 Hydrogenation Condenser ASPEN Model

Table 3.3.4-2 Hydrogenation Condenser System ASPEN Details

| Block | Type | Temperature (°C) | Pressure (Bar) | Heat Duty (MW) |
|--------------|-----------------|------------------|----------------|----------------|
| E-601 | HeatX | 176 | 30 | 7.6 |
| E-602 | Heater | 35 | 8.1 | 27.2 |
| F-601 | Adiabatic Flash | 35 | 8.1 | 0 |

3.3.5 Methanol Distillation Column Design

Modeling Via Aspen Plus

NRTL-2 is applied to account for the binary interaction between methanol and water, and a RadFrac column is used to model the distillation column. Sieve trays are placed in the distillation column as equilibrium stages. The 2022 design applied the Fenske Equation to estimate the minimum number of stages required for this distillation:

$$(Eq. 16) \quad N_{min} = \frac{\ln(X_{D,LK}X_{B,HK}/X_{B,LK}X_{D,HK})}{\ln \alpha_{LK,HK}} - 1$$

This equation suggests a minimum of 10 stages are required. Even though 10 stages are enough to complete the separation, the reboiler and condenser heat duty would be large. 20 stages are used to decrease the heat duty. The feed is set at stage 18, because the composition of the feed is most similar to the composition at this stage. A two-pass design reduces the percent flooding, and increases distillation efficiency. The distillation column is operating at 1 bar, equipped with a kettle reboiler and a total condenser. Raising the pressure would cause weeping in some stages. The total condenser is operating at 64.2°C, 1 bar and the reboiler is operating at 92.0°C, 1 bar. The parameters are obtained by trial and error until percent jet flood, weeping, and pressure drop are minimized. Column parameters are summarized in the table below.

Table 3.3.5-1 Distillation Column Parameters

| | |
|----------------------------|------|
| Stages | 20 |
| Feed Stage | 18 |
| Reflux Ratio | 0.91 |
| Boil Up Ratio | 9.07 |
| Condenser Heat Duty (MW) | 44.5 |
| Reboiler Heat Duty (MW) | 47.2 |
| Column Height (m) | 40 |
| Column Diameter (m) | 6 |
| Tray Distance (m) | 2 |
| Pressure Drop (bar) | 0.18 |
| Percent Flooding | 36.2 |
| Total Residence Time (min) | 7.16 |
| Weeping | None |

The trays are 6 m in diameter, having two passes and 22,000 1 cm in diameter holes. The distance between each tray is 2 m, giving a column height of 40 m. A graphical representation of a tray with detailed dimensions is shown below.

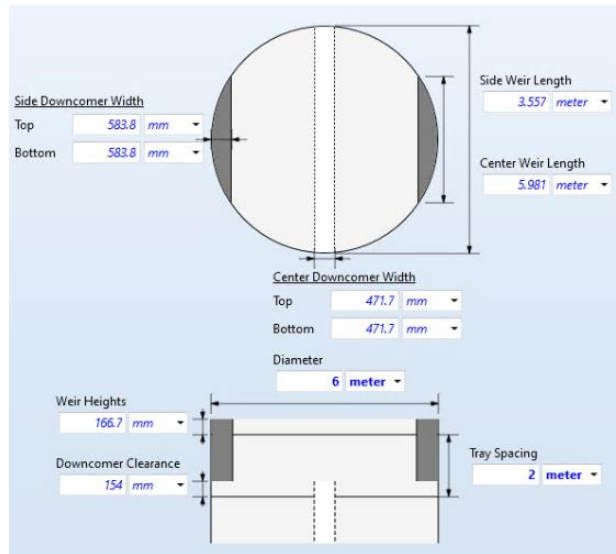

Figure 3.3.5-1 Distillation Column Tray Dimensions

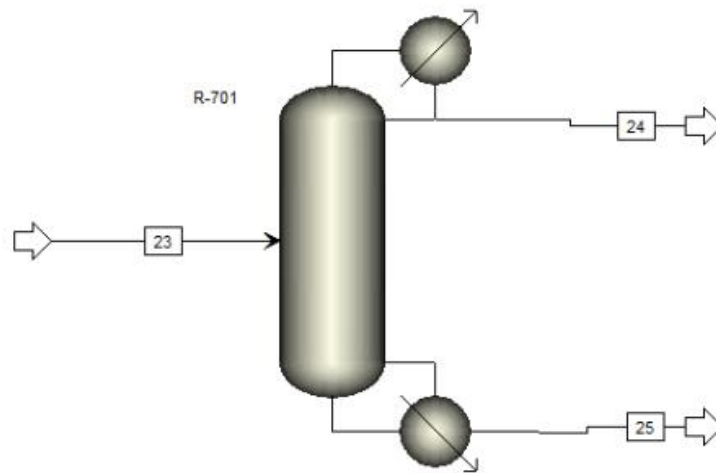

Figure 3.3.5-2 Methanol Distillation Column ASPEN Model

Material Balance

The goal of the distillation column is to produce methanol at 99.6% purity. This quality corresponds to commercial AA grade methanol that could be used in chemical synthesis. ASPEN calculated the boil up ratio to be 9.07. The optimal reflux ratio and distillate rate are found by varying these two variables, while satisfying a distillate molar methanol purity of 99.6%, a methanol molar recovery of 99% (2357 kmol/hr of methanol and 9.5 kmol/hr of water in distillate). The optimal reflux ratio is found to be 0.91, while the total flow rate of the bottom is 460 kmol/hr with 94.5% water and balanced methanol.

IV. ECONOMICS

4.1 Operating Schedule

When looking at the economics for this design, the length of construction and then the operating schedule need to be analyzed. First and foremost, the time for constructing this design is estimated to be around 18 months. Once constructed, there will need to be a start up time frame of acquiring materials and preparing the plant for full time operation. This startup time may vary, but to be on the cautious side these calculations will be done within a 6 month startup window, followed by 20 years of operation.

As previously mentioned, the plant's operating schedule will be 6000 hours per year. For this timeframe, it is important to note that it is significantly under the typical operational hours of a traditional plant, but will still be able to achieve the targeted amount of carbon captured and methanol produced. The main limiting factor on hours will be the regeneration period of the ZnO/Al₂O₃ and Cu/ZnO/Al₂O₃. The quantity of ZnO/Al₂O₃ used in the process is estimated to be active for 2000 hours before needing a regeneration period, while Cu/ZnO/Al₂O₃ is estimated to be active for 1000 hours before needing the same. With the basis for the production calculations being 6000 hours, there will be ample amount of time for regeneration of both catalysts during scheduled down time. Using the limiting 1000 hour time constraint, regeneration would need to occur every 5.95 weeks. As a precaution to not overexert the catalyst, every fifth week will be a down week for the plant for regeneration. Yearly, this equates to 40 operational weeks, 8 weeks of catalyst regeneration, and 4 weeks of downtime to give flexibility if major issues were to arise, or to increase the run time of the plant.

4.2 Annual Revenue

The economics of this project rely heavily on the market value of methanol. The process is designed to produce 0.62 Mt/year of methanol annually. From Methanex, the current market price of methanol is \$565.00 per tonne (Methanex, 2023). Additionally, the excess steam produced from this process will be sold at its market value of \$29 per tonne (Turton, 2003). From these values, as shown in Table 4.1-1, the annual revenue will be \$286 million dollars.

Table 4.1-1 Anticipated Annual Revenue

| Anticipated Annual Revenue | | | |
|-----------------------------------|-----------------------|-----------------------------|----------------------------|
| Component | Amount (kg/hr) | Unit Cost (\$/tonne) | Hourly Cost (\$/hr) |
| Methanol | 75534.3 | \$575.00 | \$43,432.22 |
| Steam | 144580.0 | \$29.00 | \$4,192.82 |
| Annual Revenue | | | \$285,750,255.00 |

4.3 Purchased Equipment and Capital Costs

Another important consideration in the project's economic viability is the capital cost required to purchase the equipment. These costs can be broken down into the major equipment costs, shown in table 4.3.1-1, and the ancillary equipment costs shown in table 4.3.2-1. These prices were calculated using the pricing values provided from their respective Aspen simulations.

4.3.1 Major Equipment

Major equipment, such as the reactors, mixers, and columns, were all priced through Aspen. All pieces of equipment are designed to fall well within a safe range for the temperatures and pressures they will be handling. This is summarized in table 4.3.1-1:

Table 4.3.1-1 Summary of Major Equipment Purchased

| Major Equipment Cost Summary | | | | |
|---------------------------------------|-----------------------|------------------|------------------------|-------------------------|
| Block | Equipment type | Unit Cost | Number of Units | Cost |
| Block 1 | | | | |
| R-101 | Air Contactor | \$114,200,000.00 | 1 | \$114,200,000.00 |
| Block 2 | | | | |
| R-201 | Pellet Reactor | \$52,209,800.00 | 1 | \$52,209,800.00 |
| Block 3 | | | | |
| R-301 +R-302 | Calciner + Separator | \$48,400.00 | 1 | \$48,400.00 |
| R-303 | Combustion Reactor | \$4,125,232.03 | 3 | \$12,375,696.08 |
| R-304 | Dryer | \$48,400.00 | 1 | \$48,400.00 |
| Block 4 | | | | |
| R-401 | Slaker | \$33,000,000.00 | 1 | \$33,000,000.00 |
| Block 5 | | | | |
| R-501 | RWGS Reactor | \$199,400.00 | 1 | \$199,400.00 |
| F-501 | Flash Drum | \$55,200.00 | 1 | \$55,200.00 |
| Block 6 | | | | |
| R-601 | Hydrogenation Reactor | \$532,500.00 | 1 | \$532,500.00 |
| F-601 | Flash Drum | \$41,500.00 | 1 | \$41,500.00 |
| Block 7 | | | | |
| R-701 | Distillation Column | \$1,222,100.00 | 1 | \$1,222,100.00 |
| DAC Capital Costs: | | | | \$211,882,296.08 |
| Methanol Capital Costs: | | | | \$2,050,700.00 |
| Major Equipment Capital Costs: | | | | \$213,932,996.08 |

4.3.2 Ancillary Equipment

The ancillary equipment, which for this project are primarily pumps and heat exchangers, were priced using the Aspen simulations. These prices are summarized in table 4.3.2-1.

Table 4.3.2-1 Summary of Ancillary Equipment Purchased

| Ancillary Equipment Cost Summary | | | | |
|-------------------------------------------|------------------------------|-----------------------|------------------------|------------------------|
| Block | Equipment type | Equipment Cost | Number of Units | Cost |
| Pumps | | | | |
| P-101 | K2CO3 Pump | \$25,709.39 | 7 | \$179,965.70 |
| P-203 | KOH Pump | \$24,769.01 | 1 | \$24,769.01 |
| P-403 | Slurry Pump | \$51,175.16 | 11 | \$562,926.74 |
| Conveyors | | | | |
| P-201 | CaCO3 Conveyor | \$112,000.00 | 1 | \$112,000.00 |
| P-202 | CaCO3 Conveyor | \$112,000.00 | 1 | \$112,000.00 |
| P-301 | CaCO3 Conveyor | \$112,000.00 | 1 | \$112,000.00 |
| P-302 | CaCO3 Conveyor | \$112,000.00 | 1 | \$112,000.00 |
| P-303 | CaO Conveyor | \$112,000.00 | 1 | \$112,000.00 |
| P-401 | CaO Conveyor | \$112,000.00 | 1 | \$112,000.00 |
| P-402 | Ca(OH)2 Conveyor | \$112,000.00 | 1 | \$112,000.00 |
| Compressors | | | | |
| C-501 | RWGS Compressor | \$8,688,628.00 | 1 | \$8,688,628.00 |
| C-601+E-504 | Hydrogenation Compressor | \$9,091,848.00 | 1 | \$9,091,848.00 |
| Heat Exchangers | | | | |
| E-301 | DAC Heat Exchanger | \$27,800.00 | 1 | \$27,800.00 |
| E-302 | DAC Heat Exchanger | \$48,400.00 | 1 | \$48,400.00 |
| E-303 | DAC Heat Exchanger | \$6,800.00 | 1 | \$6,800.00 |
| E-501 | RWGS Heat Exchanger | \$94,500.00 | 1 | \$94,500.00 |
| E-502 | RWGS Heat Exchanger | \$351,300.00 | 1 | \$351,300.00 |
| E-503 | RWGS Heat Exchanger | \$178,000.00 | 1 | \$178,000.00 |
| E-601 | Hydrogenation Heat Exchanger | \$36,300.00 | 1 | \$36,300.00 |
| E-602 | Hydrogenation Heat Exchanger | \$306,200.00 | 1 | \$306,200.00 |
| E-603 | Hydrogenation Heat Exchanger | \$40,800.00 | 1 | \$40,800.00 |
| Valve | | | | |
| V-401 | Slurry Valve | \$732.09 | 1 | \$732.09 |
| DAC Capital Costs: | | | | \$1,635,393.54 |
| Methanol Capital Costs: | | | | \$18,787,576.00 |
| Ancillary Equipment Capital Costs: | | | | \$20,422,969.54 |

4.3.4 Total Capital Cost of Plant

For the total capital cost of the plant, the final value was approximated using the Lang Factor Equation. This equation takes into account the major equipment capital costs, and multiplies this value by a factor dependent on the phases of materials in the system. Equation ## is the Lang Factor Equation, where F_{Lang} is the lang factor, C_{TM} is the total capital cost, and $C_{p,i}$ is the cost of the major equipment. Since the plant design has an upstream of the DAC and the

downstream of the methanol synthesis, the plant capital costs were divided into two sections. The DAC works with solids, liquids, and gasses, while the methanol synthesis only works with liquids and gasses. Thus, the DAC major equipment was multiplied by a Lang Factor of 3.63 while the methanol synthesis was multiplied by a Lang Factor of 4.74, the factors for a solid-fluid process and then a fluid process respectively. The resulting total capital was approximated to \$778,853,053.

$$(Eq. 17) C_{TM} = (F_{Lang}) \sum C_{p,i}$$

4.4 Operating Costs

The operating costs for this process is divided into 4 parts: raw materials, labor costs, utility costs, and waste costs. The raw materials are further divided into two parts: the capital raw material, such as the catalysts, that are a one time purchase, and the reactive raw materials that are an hourly charge. The utilities are also further divided, being split between power and water. The summary of the operating costs is shown in table 4.4-1

Table 4.4-1: Total Operating Cost Summary

| Total Operating Cost Summary (In Millions of USD) | |
|----------------------------------------------------------|--------------------|
| Operation | Yearly Cost |
| Raw Materials | \$442.84 |
| Labor | \$20.58 |
| Utilities | \$323.17 |
| Waste | \$0.02 |
| Total Yearly Cost: | \$786.61 |

4.4.1 Raw Materials

For the raw materials, this section is divided up between the one time purchase materials and the annual materials that are part of the reactions. The annual raw materials serve as the largest cost for the plant annually. Table 4.4.1-1 shows the capital raw materials while 4.4.1-2 shows the annual costs for the reacting raw materials.

Table 4.4.1-1 Raw Material Capital Costs

| Raw Material Capital Costs | | | |
|---------------------------------------|-------------|-------------------|--------------------|
| Component | Amount (kg) | Unit Cost (\$/kg) | Cost |
| ZnO/Al ₂ O ₃ | 865.0 | \$15.00 | \$12,975.00 |
| Cu/ZnO/Al ₂ O ₃ | 1398.0 | \$12.00 | \$16,776.00 |
| Ca(OH) ₂ | 4033.4 | \$0.40 | \$1,613.36 |
| KOH | 8066.7 | \$0.74 | \$5,969.36 |
| Total Material Capital | | | \$37,333.72 |

Table 4.4.1-2 Reacting Raw Material Costs

| Raw Material Costs | | | |
|--------------------------|----------------|-------------------|-------------------------|
| Component | Amount (kg/hr) | Unit Cost (\$/kg) | Hourly Cost (\$/hr) |
| Blue hydrogen | 24442.2 | \$3.00 | \$73,326.61 |
| Methane | 34486.0 | \$0.0001 | \$4.52 |
| Yearly Total Cost | | | \$442,680,679.49 |

4.4.2 Labor Costs

To determine the amount of operators the plant requires, equation ## was used as provided in the Turton textbook (Turton 2003).

$$\text{(Eq: 18) } N_{oi} = (6.29 + 31.7P^2 + 0.23N_{mp})^{1/2}$$

Where N_{oi} is the number of operators required per shift, P is the number of operating steps that handle solids, and N_{mp} is the number of major pieces of equipment. Then, since the number of operators is given as a number required per shift, the value is multiplied by a factor of 4.5 required shifts. This is summarized in table 4.4.2-1.

Table 4.4.2-1 Operating Labor Summary

| Block | Equipment type | Operating Labor Cost | | Operators Required |
|-------------------------------------|-----------------------|----------------------|-------|------------------------|
| | | Nnp | Nol | |
| Block 1 | | | | |
| R-101 | Air Contactor | 1 | 2.64 | 12 |
| Block 2 | | | | |
| R-201 | Pellet Reactor | 1 | 6.18 | 28 |
| Block 3 | | | | |
| R-301 | Calciner | | | |
| R-303 | Combustion Reactor | | | |
| R-304 | Drier | 6 | 28.29 | 127 |
| E-301 | Heat Exchanger | | | |
| E-302 | Heat Exchanger | | | |
| E-303 | Heat Exchanger | | | |
| Block 4 | | | | |
| R-401 | Slaker | | | |
| P-403 | Slurry Pump | 3 | 17.1 | 52 |
| M-401 | Slurry Mixer | | | |
| Block 5 | | | | |
| R-501 | RWGS Reactor | | | |
| E-501 | Heat Exchanger | | | |
| E-502 | Heat Exchanger | | | |
| E-503 | Heat Exchanger | 7 | 2.81 | 13 |
| E-504 | Heat Exchanger | | | |
| F-501 | Flash Drum | | | |
| C-501 | Compressor | | | |
| Block 6 | | | | |
| R-601 | Hydrogenation Reactor | | | |
| F-601 | Flash Drum | 3 | 2.64 | 12 |
| C-601 | Compressor | | | |
| Block 7 | | | | |
| R-701 | Distillation Column | 3 | 2.64 | 12 |
| Operating Labor Cost Summary | | | | |
| Total Operators | | | | 256 |
| Base Salary | | | | \$78,620.00 |
| Plant Manager | | | | \$123,587.00 |
| Operations Manager (1 per shift) | | | | \$73,070.00 |
| Total Annual Labor Cost | | | | \$20,579,122.00 |

4.4.3 Utility Costs

This process utilizes, or in the case of steam produces, multiple utilities. These utilities are the electrical power, water (cooling water and boiler water), dry air for the equipment, and low pressure steam that will be able to be sold. Table 4.4.3-1 shows the breakdown of the pricing of these utilities.

Table 4.4.3-1 Summary of Utility Pricing

| Summary of Utility Pricing | | |
|----------------------------|---------|--------------|
| Utility | Price | Per Unit |
| Electrical Substation | 0.07 | /kWh |
| Cooling water | 0.00007 | /kg |
| Boiler water | 0.00245 | /kg |
| Low Pressure Steam | 0.029 | /Kg |
| Dry instrument air | 0.005 | /cubic meter |

Tables 4.4.3-2, 4.4.3-3, and 4.4.3-4 break down these costs by electrical power, water, and steam respectively and are broken down by blocks. Overall, the utilities will cost \$323 million dollars.

Table 4.4.3-2 Utility Summary - Power

| Utility Cost Summary - Power | | | | |
|------------------------------------|-------------------------------------------|-----------|-------|---------------------|
| Block | Equipment type | Amount | Units | Hourly Cost (\$/hr) |
| Block 1 | | | | |
| R-101 | Air Contactor Power | 58.72 | kW | \$4.11 |
| P-101 | K ₂ CO ₃ Pump Power | 1316.00 | kW | \$92.12 |
| P-102 | KOH Pump Power | 398.10 | kW | \$27.87 |
| Block Hourly Cost: | | | | \$124.10 |
| Block 2 | | | | |
| R-201 | Pellet Reactor Power | 58.72 | kW | \$4.11 |
| P-201 | CaCO ₃ Conveyor Power | 7.46 | kW | \$0.52 |
| P-202 | CaCO ₃ Conveyor Power | 7.46 | kW | \$0.52 |
| Block Hourly Cost: | | | | \$5.15 |
| Block 3 | | | | |
| R-304 | Dryer Power | 163579.00 | kW | \$11,450.53 |
| P-301 | CaCO ₃ Conveyor Power | 5.22 | kW | \$0.37 |
| P-302 | CaCO ₃ Conveyor Power | 5.22 | kW | \$0.37 |
| P-303 | CaO Conveyor Power | 3.73 | kW | \$0.26 |
| Block Hourly Cost: | | | | \$11,451.52 |
| Block 4 | | | | |
| P-401 | CaO Conveyor Power | 3.73 | kW | \$0.26 |
| P-402 | Ca(OH) ₂ Conveyor Power | 5.60 | kW | \$0.39 |
| P-403 | Slurry Pump Power | 174157.50 | kW | \$12,191.03 |
| Block Hourly Cost: | | | | \$12,191.68 |
| Block 5 | | | | |
| R-501 | RWGS Reactor Power | 3948.66 | kW | \$276.41 |
| C-501 | Compressor Power | 22208.56 | kW | \$1,554.60 |
| Block Hourly Cost: | | | | \$1,831.01 |
| Block 6 | | | | |
| C-601 | Compressor Power | 24079.89 | kW | \$1,685.59 |
| Block Hourly Cost: | | | | \$1,685.59 |
| Block 7 | | | | |
| R-701 | Condenser Power | 97.08 | kW | \$6.80 |
| Block Hourly Cost: | | | | \$6.80 |
| Total Power Required per Hour (kW) | | | | 388,094.18 |
| Total Power Required per Year (kW) | | | | 2,328,565,100.67 |
| Annual Power Cost | | | | \$162,999,557.05 |

Table 4.4.3-3 Utility Summary - Water

| Utility Cost Summary- Water | | | | |
|------------------------------------|-------------------|---------------|--------------|-----------------------|
| Block | Water Type | Amount | Units | Cost/hr |
| Block 5 | | | | |
| E-502 | Boiler Feed Water | 66657 | kg/hr | \$163.31 |
| E-503 | Boiler Feed Water | 66256 | kg/hr | \$162.33 |
| Block Hourly Cost: | | | | \$325.64 |
| Block 6 | | | | |
| R-601 | Boiler Feed Water | 67606 | kg/hr | \$165.63 |
| E-601 | Boiler Feed Water | 9549 | kg/hr | \$23.40 |
| E-602 | Boiler Feed Water | 38177 | kg/hr | \$93.53 |
| Block Hourly Cost: | | | | \$282.56 |
| Block 7 | | | | |
| R-701 | Cooling Water | 1278650 | kg/hr | \$89.51 |
| Total Hourly Cost | | | | \$697.71 |
| Annual Water Cost | | | | \$4,186,234.50 |

For steam, the positive number represents the steam generated via the respective blocks, while negative numbers in table 4.4.3-4 represent areas where heat integration was used, and steam is consumed. The overall positive value here for steam represents the amount of low pressure steam that will be able to be sold. The figure also shows the amount of dry air that is being used in the process for the slaker.

Table 4.4.3-4 Utility Summary - Steam and Dry Air

| Utility Cost Summary - Steam | | | |
|----------------------------------------|---------------------|-----------------------|----------------------------|
| Block | Steam Type | Amount (kg/hr) | Hourly Cost (\$/hr) |
| Block 5 | | | |
| E-501 | Steam Consumption | -18916 | -\$548.56 |
| E-502 | LP Steam Generation | 66657 | \$1,933.05 |
| E-503 | LP Steam Generation | 66256 | \$1,921.42 |
| Block Hourly Cost: | | | \$3,305.91 |
| Block 6 | | | |
| R-601 | LP Steam Generation | 67606 | \$1,960.57 |
| E-601 | LP Steam Generation | 9549 | \$276.92 |
| E-602 | LP Steam Generation | 38177 | \$1,107.13 |
| E-603 | Steam Consumption | -7207 | -\$209.00 |
| Block Hourly Cost: | | | \$3,135.63 |
| Block 7 | | | |
| R-701 | Steam Consumption | -77542 | -\$2,248.72 |
| Block Hourly Cost: | | | |
| Total Steam Generated - Steam Consumed | | 144580 | |
| Hourly Steam Profit | | | \$4,192.82 |
| Yearly Steam Profit | | | \$25,156,920.00 |

| Utility Cost Summary - Dry Air | | | |
|---------------------------------------|-----------------------|-----------------------|----------------------------|
| Block | Equipment Type | Amount (kg/hr) | Hourly Cost (\$/hr) |
| Block 4 | | | |
| E-402 and E-403 | Heat Exchanger | 115840.0 | \$448.99 |
| Yearly Air Cost | | | \$2,693,953.49 |

4.4.4 Waste Costs

For this process, there are no waste streams of significance from the DAC part of the process and only 2 streams of note from the methanol synthesis portion. While the majority of the methanol in this process is collected as product from the distillation, streams 17 and 24, the RWGS condenser and distillation bottoms streams respectively, contain some of the methanol. These streams will need to be sent to a wastewater treatment facility before being released into whatever

water system the stream may end up in. Using Turton table 8.3, the cost of waste is based on the tertiary waste treatment price (\$56/1000 m³), as chemical processing will be needed.

Table 4.4.4-1 Summary of Waste Costs

| Waste Stream Cost | | | |
|---------------------------|--------------------|----------------------------------|--------------------------|
| Stream | Description | Amount (m³/hr) | Total Hourly Cost |
| 17 | RWGS Waste | 60.74 | \$3.40 |
| 25 | Distillation Waste | 9.56 | \$0.54 |
| Total Yearly Cost: | | | \$23,620.80 |

4.5 Cost of Manufacturing

The cost of manufacturing is broken down into fixed costs, direct costs, and general manufacturing costs. Fixed costs are costs not dependent on the rate of production of the plant, direct costs are dependent on the rate of production of our product (methanol), and general manufacturing costs relate to administrative and development costs. Using the equation provided in the Turton textbook, these values were calculated and are shown in table 4.5-1.

Table 4.5-1 Manufacturing Cost Summary

| Manufacturing Cost Summary | | |
|--------------------------------------|---------------------|---------------------------------------|
| Category | Estimation | Annual Cost (Thousands of USD) |
| Direct Costs: | | |
| Raw Materials | CRM | \$442,680 |
| Operating Labor Cost | COL | \$20,579 |
| Utilities Cost | CUT | \$169,879 |
| Direct Supervisory and Clerical Labo | 0.18COL | \$3,704 |
| Maintenance and Repairs | 0.06FCI | \$46,731 |
| Operating Supplies | 0.009FCI | \$7,010 |
| Laboratory Charges | 0.15COL | \$3,087 |
| Patents and Royalties | 0.03COM | \$46,549 |
| Fixed Costs: | | |
| Depreciation | 0.1FCI | \$77,885 |
| Local Taxes and Insurance | 0.032FCI | \$24,923 |
| Plant Overhead Costs | 0.708COL + 0.036FCI | \$42,609 |
| General Costs | | |
| Administration Costs | 0.177COL + 0.009FCI | \$10,652 |
| Distribution and Selling Costs | 0.11COM | \$170,681 |
| Research and Development | 0.05COM | \$77,582 |
| Total Costs (COM): | | \$1,551,648 |
| Total Costs + Depreciation: | | \$1,629,533 |
| Total Capital Cost Summary | | |
| | Estimation | Annual Cost (Thousands of USD) |
| Fixed Capital Investment | FCI | \$778,853 |
| Working Capital Investment | 0.15FCI | \$116,828 |
| Total Capital Cost | | \$895,681 |

4.6 Cash Flow Analysis

The cash flow analysis of this project shows a major issue: the yearly cash flow is negative. As discussed previously, the yearly raw material cost is too significant to be balanced out by the revenue, let alone when the operation costs are added in as well. 10-year straight line depreciation was incorporated and calculated to be \$77,885,000 annually. Figure 4.6-1 shows the cumulative cash flow for this project.

Currently, there is a \$130/tonne captured CO₂ tax credit for any facilities using DAC as per the Inflation Reduction Act, Section 45Q. The benefits of the recent improvements to the tax credit allows the credit to be offered “direct pay” or where the credit can basically be treated as a subsidy. Profit margins for our process are razor thin, as is common with first-of-a-kind projects that invest in DAC. Given we are capturing almost 1 million tonnes of CO₂ per year, this provides a valuable opportunity for our plant to have another source of income. Other profit sources include methanol and low pressure steam, which we have priced at general market prices to determine our base cash flow. However, even including the direct pay credit from the Inflation Reduction Act our cumulative cash flow is not profitable.

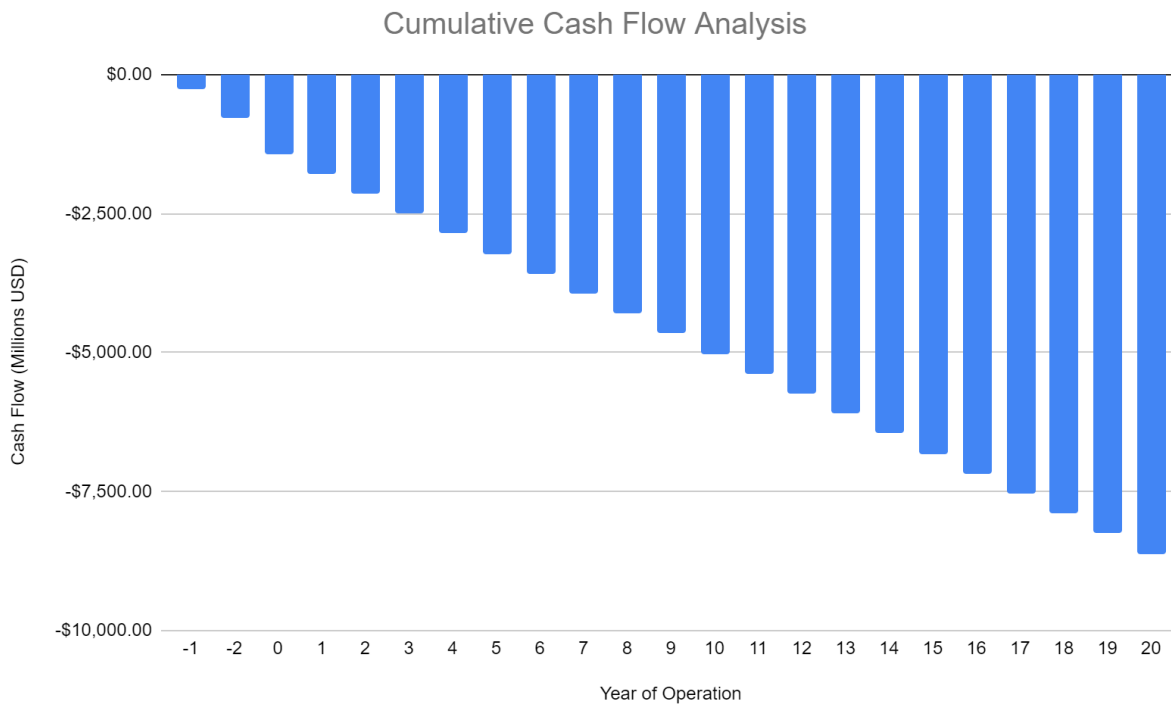

Figure 4.6-1 Cumulative Cash Flow Analysis

As shown in Figure 4.6-1, our yearly cash flow is severely negative, specifically negative 359 million per year. Since there is no net revenue, we were unable to calculate taxes or depreciation on this evaluation. It can be deduced that this process is not worthy of investment unless further work could be done to increase the economic viability.

4.7 Scenarios

From the cash flow analysis, it is clear that this project is not economically viable in its current state. However, there are a few considerations that, when taken into account or even altered slightly, could provide a vastly different economic outcome. We've tested out three scenarios which aim to make our plant economically viable: a theoretical increased carbon credit, using natural gas derived hydrogen combined with a methanol premium, and a high premium price on methanol.

Scenario 1: Carbon Credits

This scenario entertains the idea where a higher carbon credit would make our design breakeven with capital investment after 5 years of operation. A \$650/tonne captured CO₂ carbon credit, treated as a subsidy, was chosen arbitrarily to demonstrate what a theoretical carbon credit would need to be to be able to continue selling methanol at our current price. Norway's Climate Action Plan 2021-30 proposes to raise the carbon subsidy from NOK 590 (USD 69) per tonne of CO₂ in 2021 to NOK 2000 (about USD 233) by 2030 (OECD, 2022). This is one of the higher examples of carbon tax proposals and while it is greater than the current US subsidy, it is still shy of the amount suggested in this scenario. While impractical, this scenario shows how carbon tax subsidies alone cannot reasonably be the main source of income for DAC projects like this design.

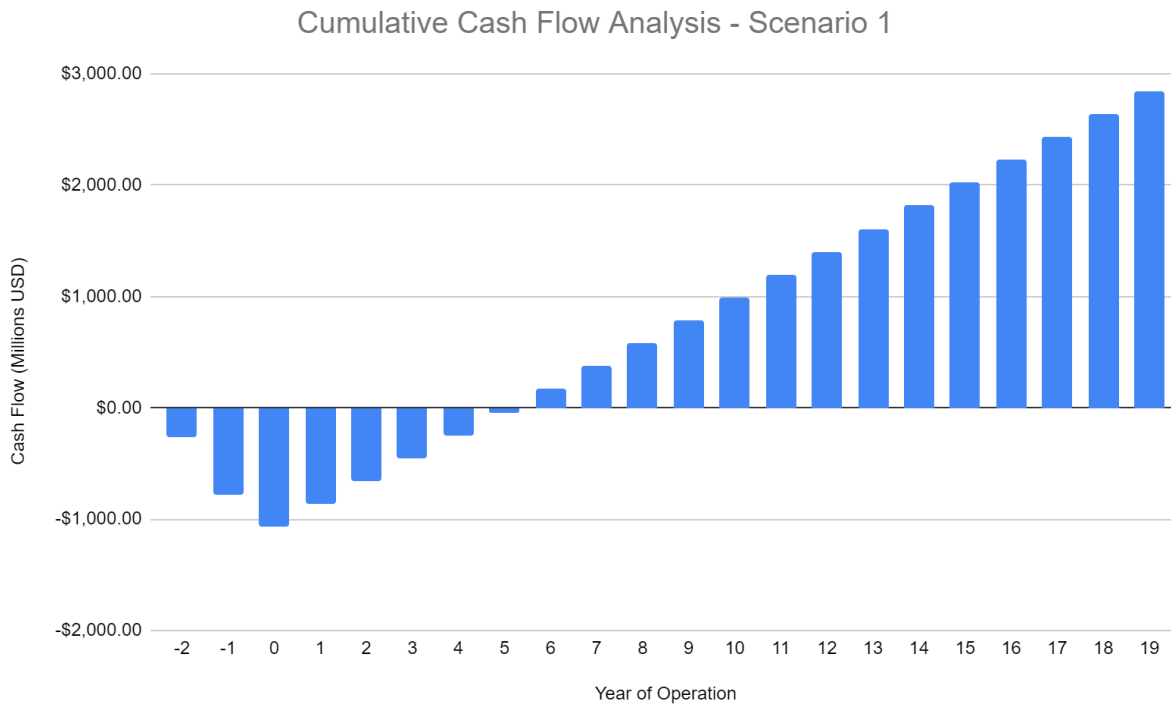

Figure 4.7-1 After-Tax Cash Flow Analysis of Scenario 1

Scenario 2: Premium Pricing for Green Methanol

This scenario significantly increases the price of methanol, marketing it as premium methanol due to its sustainability: both from using blue hydrogen and for being a direct air capture project. Many consumers and business entities purchasing methanol may be incentivised to purchase sustainably and market their resulting products as sustainable as well. The current market price for methanol is \$575 per tonne, and the increased premium price is \$2000 per tonne. Sources cite that methanol can be sold at prices as high as \$2400/tonne (Greenhaleg, 2021). Figure 4.7-2 shows the cumulative cash flow for this scenario.

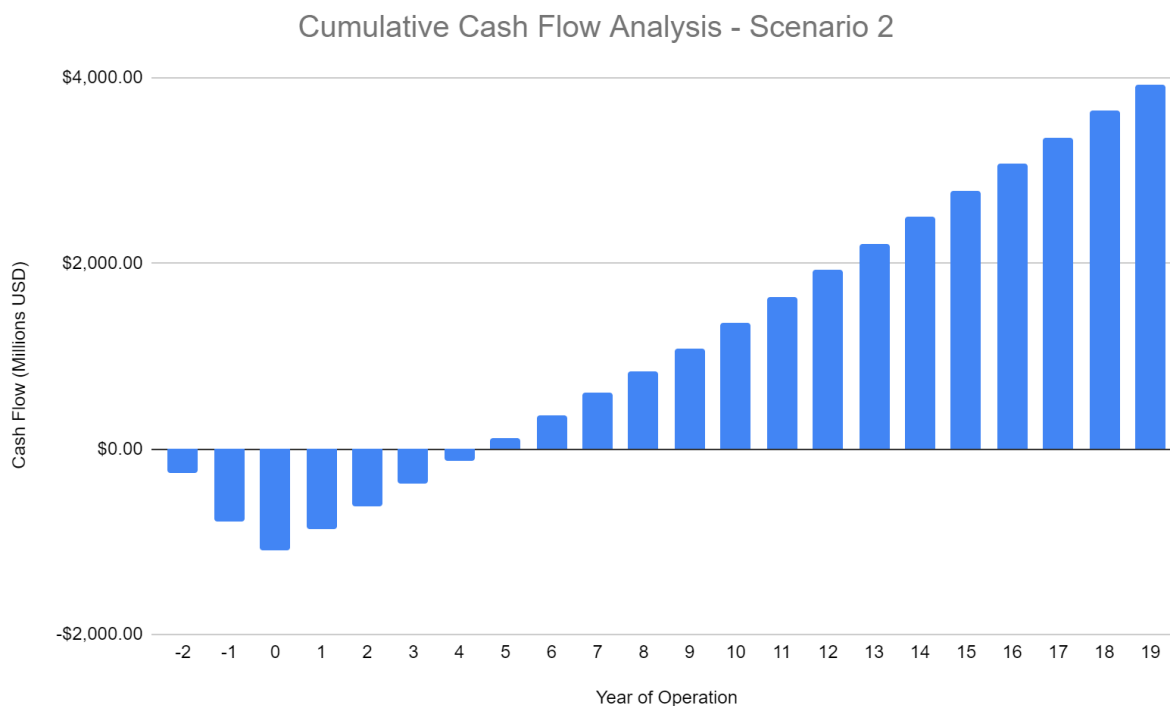

Figure 4.7-2 After-Tax Cash Flow Analysis of Scenario 2

From this graph, the cumulative cash flow becomes positive 5 years and shows a profit can be made. However, with methanol being such a mainstream market chemical, the likelihood of companies willing to pay an almost 350% price hike is slim. There is plausibility to this scenario, as other green sources have price hikes in a similar range, such as hydrogen, but there are still some doubts as to whether this scenario would be able to work.

Scenario 3: Grey Hydrogen

In our base design, blue hydrogen was used via a nearby facility to have a more environmentally friendly hydrogen source. However, this hydrogen is much more expensive than the general market hydrogen, referred to as gray hydrogen. Grey hydrogen can go for as low as \$0.40 per kg, however this was still not quite low enough to achieve a positive cash flow. Thus, utilizing a combination of the gray hydrogen and the premium pricing of methanol was used. This premium methanol price is \$1000 per tonne, much lower than what was needed for the scenario of just the premium price. As shown in figure 4.7-3, this scenario results in the cumulative cash flow becoming positive after 4 years in operation.

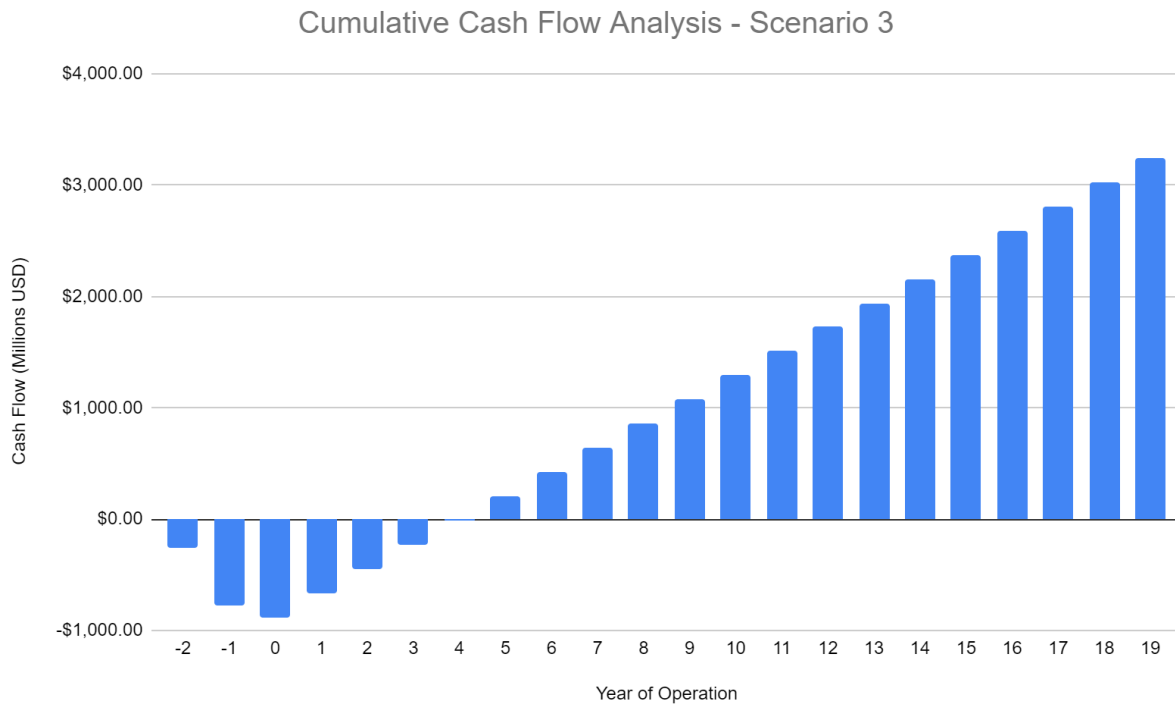

Figure 4.7-3 After-Tax Cash Flow Analysis of Scenario 3

Of the scenarios, this is shown to be the most profitable one, however, the usage of gray hydrogen does go against our original goal of mitigating climate change by reducing emissions. While still removing carbon dioxide from the air, using natural-gas derived hydrogen is less sustainable and would reduce our net carbon captured from the atmosphere. This means marketing the product methanol as sustainable methanol to warrant the premium price is less reasonable. There is still plausibility shown here, and a lucrative opportunity can be shown to investors who are willing to be patient for the first few years to get off the ground.

V. ENVIRONMENTAL CONSIDERATIONS

5.1. Direct Air Capture

The carbon capture and conversion impact, being the driving force of this report, is one of the most important environmental aspects. The process described throughout this report is designed to capture 0.98Mt-CO₂/year from the atmosphere, thus providing a strong combatant against the ever rising issue of greenhouse gas emissions. However, this positive impact does not mean that any potential negatives can be ignored. The air contactor poses one such potential threat from the particles that can be released. Drift, or the movement of particles in air or in a liquid to an unintended location, poses a threat due to the potential potassium hydroxide drift that could occur. Moving onto the pellet reactor, various chemicals in this part of the process are known to pose hazards. More on this will be discussed in the safety considerations section, but it is important to make sure this is a closed part of the process so that none of the potentially harmful chemicals escape.

For the calciner, the most notable impact is from the extreme heat. Heat pollution poses a significant threat to surrounding ecosystems if allowed to escape. However, as this part of the process is adiabatic, the heat will remain in the system unless a leak were to occur. Similarly, the slaker is being run at high temperatures that could pose a threat to the environment if a leak were to occur. However, with the chosen location of Midland, Texas for the plant, the geography of the site is a sedimentary basin which would be less affected by a large heat release than a more forested area (Britannica 2015).

5.1.1 Waste Streams

The main source of waste from the direct air capture part of the plant is stream 2, the purge stream. This stream is a purge stream from the air contactor, but primarily is influenced by the purging of the pellet reactor that is flown through the contactor to reduce the CO₂. Thus, with the air contactor helping to purify the stream before being released combined with the large amount of CO₂ taken out of the atmosphere by the process already leads to this purge being insignificant in calculations.

5.2 Methanol Synthesis

While the primary possible environmental impacts of this process are in the direct air capture portion, there are still some key factors that should be mentioned in the methanol synthesis. One of the primary pollutants that could escape this portion is the CO produced in the RWGS reaction. While this should be contained in the system through the hydrogenation reaction and recycling to extinction, it is important to consider in the case of any disasters or mishaps in the process. Another part of this process is that water will be taken out of the system at two different places and will need to be considered due to the potential contamination hazards.

5.2.1 Synthetic Gas (Syngas)

For the process, if a leak were to ever occur, synthetic gas, or syngas, is one of the largest potential impacts. Syngas is a mixture of CO and H₂, and potentially contains CO₂ or CH₄. This needs to be closely monitored, as CO can have a severe impact on the surrounding environment. Syngas poses a significant threat to climate change due to the longevity of the gas and its ability to trap heat in the atmosphere (Department of Climate Change, Energy, the Environment and Water, 2021).

5.2.2 Waste Streams

There are two main waste streams in the methanol synthesis process of the plant, one being the reverse water gas shift waste and the second being the bottom product of the distillation column. While these streams are primarily water, they cannot just be sent to a generic drainage system due to there being methanol contamination. In order to protect the waterways from being contaminated with methanol, biodegradation of the methanol in the water can be achieved via the introduction of microbes. This would purify the water to safe levels so that the water could then be reintroduced into the system, or sent to the sewage system without any concern. Another possible contaminant is the CO₂ produced in the reverse water gas shift, however this CO₂ will be recycled to extinction and poses no potential threat unless a leak in the system occurs.

VI. SAFETY CONSIDERATIONS

6.1 Chemical Hazards and Compatibility

6.1.1 Direct Air Capture Chemical Hazards and Compatibility

For this process of methanol synthesis via carbon capture and conversion, there are many hazards associated with the chemicals. Proper safety procedures must be used so that the risk of using these chemicals is mitigated. These risks can range from the hazards of the individual chemicals to what can happen when different chemicals are mixed within the process. For the DAC portion of the process, the main chemicals that need to be analyzed are calcium carbonate, calcium hydroxide, calcium oxide, potassium carbonate, and potassium hydroxide. Table 6.1.1 shows the NFPA values and the chemical compatibility.

| NFPA Health Flammability Instability Special | | | | Y: Compatible N: Incompatible C: Caution SR: Self- Reactive *: Changed by user | | CALCIUM CARBONATE | CALCIUM HYDROXIDE | CALCIUM OXIDE | METHANE | OXYGEN | POTASSIUM CARBONATE | POTASSIUM HYDROXIDE, SOLUTION |
|-----------------------------------------------------------------|---|---|-----|--------------------------------------------------------------------------------------------|--|-------------------|-------------------|---------------|---------|--------|---------------------|-------------------------------|
| | | | | Direct Air Capture Compatibility Chart | | | | | | | | |
| | | | | | | | | | | | | |
| | | | | | | Y | | | | | | |
| 3 | 0 | 1 | | | | Y | Y | | | | | |
| 2 | 4 | 0 | | | | Y | Y | Y | | | | |
| 3 | 0 | 0 | Oxi | | | N | N | N | N | | | |
| 2 | 0 | 0 | | | | Y | Y | Y | Y | N | | |
| 3 | 0 | 1 | | | | C | C | C | Y | N | C | |

Table 6.1.1-1 DAC Chemical Compatibility Matrix

Calcium carbonate does not have any known long term health effects, but can cause irritation to the skin or eyes if it comes in contact, as well as coughing and nose irritation if inhaled. For calcium hydroxide, the same irritation can occur, but on a much more severe level and even leave lasting effects. Furthermore, if calcium hydroxide is inhaled, it can lead to lasting breathing

complications. Calcium oxide is again similar to calcium carbonate with the short term effects, but can also lead to pulmonary edema if someone inhales a high concentration of the chemical. For long term effects, extended exposure to calcium oxide can lead to skin damage. Potassium carbonate and potassium hydroxide can but cause serious skin and eye irritation, to the extent that exposure can lead to chemical burns. Potassium carbonate can pose a significant threat to aquatic life if a leak was to get into a waterway, as it could increase the pH of said waterway. For potassium hydroxide, it has the potential to cause pulmonary edema and bronchitis.

For all of these chemicals, skin contact and inhalation are shown to be risks that can easily be avoided. PPE to ensure workers do not come in contact with the chemicals, as well as having clean air when in the vicinity are vital to a safe work environment. Furthermore, routine maintenance on all equipment is a necessity to make sure that leaks do not occur and put ant people or the surrounding environments at risk.

In addition to the chemical hazards, high temperatures are also a significant concern for this part of the process. The dryer is operating at 900°C, which has the potential to injure workers who come in contact with the equipment or materials exiting the machine. Though it is not likely, if methanol or leaking gas from a part of this process were to come into contact with this heat, it could lead to an explosion or fire. A facility siting analysis will have to be performed as well as an official HAZOP, dispersion analysis, and LOPA to ensure that this source of extreme heat does not pose a risk to other aspects of this facility and its workers. In addition, any necessary repairs made to this machinery will require a Management of Change review and non-routine work permits such as maintenance, hot work, and energy isolation permits for this unit.

6.1.2 Methanol Synthesis Chemical Hazards and Compatibility

For the methanol synthesis, most of the chemicals used do not pose hazards. Table 6.1.2 shows the NFPA values and compatibility for the chemicals used.

Y : Compatible
N : Incompatible
C : Caution
SR : Self-Reactive
 * : Changed by user

| NFPA | | | Methanol Synthesis Compatibility Chart | ALUMINUM OXIDE | CARBON DIOXIDE | CARBON MONOXIDE | COPPER | HYDROGEN | METHANOL | WATER | ZINC OXIDE, CRUDE | | |
|--------|--------------|-------------|----------------------------------------|-------------------|----------------|-----------------|--------|----------|----------|-------|-------------------|--|--|
| Health | Flammability | Instability | | Special | | | | | | | | | |
| | | | | ALUMINUM OXIDE | | | | | | | | | |
| | | | | CARBON DIOXIDE | Y | | | | | | | | |
| 3 | 4 | 0 | | CARBON MONOXIDE | Y | Y | | | | | | | |
| | | | | COPPER | Y | Y | N | | | | | | |
| 0 | 4 | 0 | | HYDROGEN | Y | Y | Y | N | | | | | |
| 1 | 3 | 0 | | METHANOL | Y | Y | C | Y | C | | | | |
| | | | | WATER | Y | Y | Y | Y | Y | | | | |
| | | | | ZINC OXIDE, CRUDE | C | Y | Y | Y | Y | Y | N | | |

Figure 6.1.2-1 Methanol Synthesis Compatibility Matrix

Out of these chemicals, the only ones of note are carbon monoxide and methanol. Exposure to carbon monoxide can lead to carbon monoxide poisoning, which can cause “headache, dizziness, weakness, upset stomach, vomiting, chest pain, and confusion. CO symptoms are often described as “flu-like.” If you breathe in a lot of CO it can make you pass out or kill you (CDC, 2023). Having carbon monoxide detectors around the plant would be a good safety measure in case of a leak. For methanol, ingesting the chemical can cause adverse health effects. This can lead to nervous system damage, permanent visual deficits, respiratory and circulatory failure, and in significant cases, death (National Library of Medicine, 2022).

Another important consideration is the syngas produced by the RWGS process. Accumulation of sufficient amounts of syngas can lead to a fire/explosion in the presence of an ignition source and significant oxygen (WorkSafe BC, 2017). Also, with the CO being released, the environmental hazards must be considered, as reducing greenhouse pollution is one of the motivational factors for this project. From the NFPA values, there are multiple chemicals that are shown to be flammable in this process. Thus, proper fire safety precautions must be taken to ensure the safety of everyone who may be on site including a HAZOP and Conduct of Operations analysis for loss of primary containment and fire risks. Having a sprinkler system through any indoor

facilities, as well as fire hoses that can reach every part of the plant that poses a threat is important to help mitigate risk in the event of a fire starting. With there being sections of this process that operate at extremely high temperatures, isolating these away from the more flammable chemicals is another way to help prevent an explosion. Furthermore, any person who is on site should be wearing PPE and have access to other safety equipment in case of an emergency.

6.2 Safety Culture

For this site, making sure a strong safety culture is instilled in anyone on site is vital. Safety culture is defined as the normal way things are done at a facility, reflecting expected organizational values, beliefs, and behaviors, that set the priority, commitment, and resource levels for safety programs and performance. This culture must be a priority, a core value of the organization, and the primary driver for a successful enterprise. A poor safety culture will lead to workers intentionally pursuing higher risk options which could potentially get them killed. Making sure all workers are properly trained before starting on site work, as well as having regular safety meetings to make sure that personnel do not get complacent is vital to the safety of everyone. A well established line of communication between all positions at the plant must be maintained. If these values are instilled in everyone, it will help to protect the plant as a whole and people will be able to assist when they see potential mistakes from coworkers or possible plant malfunctions. This way, people at all levels within the facilities will have a way to voice concerns on issues and help prevent potential accidents.

VI. SOCIAL CONSIDERATIONS

7.1 Social Impacts

As this is a direct air capture plant targeting CO₂ emissions, the major societal impact is that of combating climate change. With this positive impact on climate change, this project can hold a strong, positive standing with people in the Midland community. While the necessary amount of CO₂ that needs to be removed from the atmosphere to truly combat climate change is much higher, every little bit does help and provides a positive impact. However, it is important to note that the large-scale size of this plant means that a large plot of land will be needed, and could affect residential areas. The plant is located at a safe distance from housing, but weather can be unpredictable and could potentially impact the area, even with the low chance.

7.2 Facility Siting

For this project, Midland, Texas was chosen as the location. This is an optimal location for the project due to the proximity of a methane pipeline and the Blue Hydrogen, thus allowing for direct pipelines to our facility. This makes for an inherently safer plant that would need less storage for these flammable materials. Furthermore, due to the large size of the plant, a positive impact can be made with local residents with the offer of a new job opportunity in town.

VII. FINAL RECOMMENDED DESIGN

7.1 Direct Air Capture and Power Island

Air Contacting

This block is responsible for capturing ambient air to be used in the carbon capture process and removing the carbon dioxide from the captured air. This block consists of the air contactor and the air contactor pump. The air contactor pump transfers the potassium carbonate capture solution from the air contactor to the pellet reactor. A summary of the equipment in this block is provided in the table below:

Table 7.1-1 Equipment Summary for Air Contacting

| Equipment ID | Equipment Type | Description | Relevant Streams | Specifications |
|---------------------|-----------------------|-------------------------------------------------------------------------------------------------------------------------------------------------------|-------------------------|----------------------------------------------------------------------------------------------------------------------------------------------------------------------------------------------------------------------------------------------------------------------------|
| R-101 | Gas absorption tower | This system uses a series of fans to draw in air and a basin and a solution of potassium hydroxide to separate the carbon dioxide from the air stream | 1,2,3, 4 | Operating Temperature: 25°C Operating Pressure: 1 atm Heat Duty: 0 MW Film width: 50 μ m Packing depth: 7 m Cross-flow air configuration Mass transport coefficient: 1.3 mm/s Air velocity: 1.4 m/s Packing Pressure Drop: 9.7 Pa/m at 1.4 m/s |
| P-101 | Pump | Transfers the potassium carbonate capture solution from the air contactor to the pellet reactor | 3 | Total Friction Loss: 101.3 kPa Gravity Head: 0 kPa Differential Pressure: 101.3 kPa Hydraulic Power: 131.6 kW Electric Draw: 188.0 kW |

Pellet Reactor

This block is used to form calcium carbonate pellets through a salt metathesis reaction between potassium carbonate from the air contactor and calcium hydroxide from the slaker. This block produces calcium carbonate, which is sent to the calciner to be decomposed. The unit consists of the pellet reactor and a pump. The pump moves the regenerative solution from the pellet reactor to the air contactor to supply potassium hydroxide. A summary of the equipment in this block is provided in the table below:

Table 7.1-2 Equipment Summary for Pellet Reactor

| Equipment ID | Equipment Type | Description | Relevant Streams | Specifications |
|---------------------|--------------------------------------|-----------------------------------------------------------------------------------------------------------------------------------------------------------------------------------------------------------------------------------------------------------------|-------------------------|-----------------------------------------------------------------------------------------------------------------------------------------------------------------------------------------------------------------------------------------------------------------------------------------------------------------------------------------|
| R-201 | Adiabatic fluidized bed crystallizer | This system is a concrete reactor which forms calcium carbonate pellets through a salt metathesis reaction to send pellets to the calciner to be decomposed. It also contains a 20 mesh shaking screen to catch fines to be reintroduced to the top of the bed. | 3,4,11,5A | Operating Temperature: 25 °C Operating Pressure: 1 atm Heat Duty: -178 MW Pumping efficiency: 82% Spiractor configuration Conical feed sections Fluidization velocity: 1.65 cm/s Bed height: 4.5 m Pellet size: >0.85 mm First Pass Calcium retention: 90% Fluid pumping energy: 27 kWh/t-CO ₂ |
| P-203 | Pump | Transports the regenerative solution from the pellet reactor to the air contactor to supply potassium hydroxide. | 4 | Total Friction Loss: 101.3 kPa Gravity Head: 233.2 kPa Differential Pressure: 369.2 kPa Hydraulic Power: 278.7 kW Electric Draw: 398.1 kW |

Calciner

The calciner in this design is a dual-layer rotary indirect-fired calciner. The outer shell is heated by an exterior combustion chamber which burns methane and ambient air to generate heat for the calciner, which operates at 898°C, the second highest temperature of operation after the combustion reactor. The calciner facilitates the decomposition of calcium carbonate pellets formed in the pellet reactor and through an endothermic reaction produces calcium oxide and carbon dioxide.

Table 7.1-3 Equipment Summary for Calciner

| Equipment ID | Equipment Type | Description | Relevant Streams | Specifications |
|---------------------|---------------------------------|---------------------------------------------------------------------------------------------------------------------------------------------|-------------------------|-------------------------------------------------------------------------------------------|
| R-301 | Rotary indirect-fired calciner | Calcining reaction converts solid CaCO_3 to solid CaO and CO_2 . | 7B, 8 | Temperature: 898°C Pressure: 1 atm Heat Duty: 271.7 MW Extent of Reaction: 0.98 |
| R-302 | Separator | This unit is, in reality, incorporated into the calciner design but was functional in ASPEN to specify the separated gas and solid streams. | 8, 9A, 12 | Temperature: 898°C Pressure: 1 atm |
| R-303 (and M-301) | Combustion reactor (and mixer) | Generates methane-derived heat for calciner reaction | 26, 27, 28, 29 | Temperature: 898°C Pressure: 1 atm Heat Duty: -271.7 MW Extent of Reaction: 1.00 |
| R-304 | Dryer, modeled as a Flash2 unit | Dries CaCO_3 solids | 5B, 6, 7A | Temperature: 105°C Pressure: 1 atm Heat Duty: 163.6 MW |

| | | | | |
|-------|--------------------------------------------------|-------------------------------------------------------------------------------------------------------------------|----------------|-------------------------------------------------------------------------------------------------------|
| E-301 | Fluidized bed heat exchanger, modeled as a HeatX | Preheats CaCO ₃ before they are sent to the dryer (uses hot dry air to heat pellets) | 5A, 5B | Temperature: °C Pressure: 1 atm Heat Duty: 30.4 MW Heat Exchanger Area: 297.7 m ² |
| E-302 | Fluidized bed heat exchanger, modeled as a HeatX | Preheats CaCO ₃ before they are sent to the calciner (uses hot gases exiting separator to heat solids) | 12, 13, 7A, 7B | Temperature: °C Pressure: 1 atm Heat Duty: 23.9 MW Heat Exchanger Area: 58.6 m ² |
| E-303 | Fluidized bed heat exchanger, modeled as a HeatX | Cools CaO exiting the calciner before sending them to slaker (uses ambient dry air to cool solids) | 9A, 9B | Temperature: °C Pressure: 1 atm Heat Duty: 30.5 MW Heat Exchanger Area: 541.0 m ² |

Slaker

This unit hydrates the calcium oxide formed in the calciner that is used in the pellet reactor to form calcium carbonate. This system consists of the slaker, a pump, and a slurry valve. The pump carries the slaker's slurry mixture to the pellet reactor and the valve reduces the pressure of the slurry mixture from 10 bar to 1 bar to enter the pellet reactor at its operating temperature. A summary of the equipment in this block is provided in the table below:

Table 7.1-4 Equipment Summary for Slaker

| Equipment ID | Equipment Type | Description | Relevant Streams | Specifications |
|---------------------|---------------------------------|----------------------------------------------------------------|-------------------------|-----------------------------------------------------------------------------------|
| R-401 | Refractory lined, fluidized bed | A refractory lined, fluidized bed reactor that is fluidized by | 6, 9B, 10 | Operating Temperature: 100 °C Operating Pressure: 10 bar Heat Duty: -246 MW |

| | | | | |
|-------|------------|---------------------------------------------------------------------------------------------------------------------------------------------------------------------------------------------------------------------|--------|---------------------------------------------------------------------------------------------------------------------------------------------------------------|
| | reactor | recirculating steam flow which captures and slakes CaO pellets to convert them into Ca(OH) ₂ . The finer particle bypass the cyclone and are captured in a dust collector and reintroduced to the system | | Fluidization velocity: 1 m/s Extent of Reaction: 0.85 |
| P-403 | Pump | Carries the slurry mixture containing Ca(OH) ₂ to the pellet reactor. | 11 | Total Friction Loss: 101.3 kPa Gravity Head: 98851.9 kPa Differential Pressure: 98953.2 kPa Hydraulic Power: 11082.8 kW Electric Draw: 15832.5 kW |
| V-401 | Ball Valve | 2'' metal seated full port ball valve | 10, 11 | Pressure Drop: 9 bar Valve opening: 70% Valve flow coefficient: 68.32 Pressure recovery factor: 0.74 |

7.2 Methanol Synthesis

Reverse Water Gas Shift Reactor

This block involves the production of CO and CO₂ syngas through the reverse water gas shift reaction, and the removal of excess water. This block consists of four heat exchangers, one flash drum, one packed bed reactor, and one compressor. A summary of required equipment, design specifications, and relevant streams is provided below.

Table 7.1-5 Equipment Summary for Reverse Water Gas Shift Reactor

| Equipment ID | Equipment Type | Description | Relevant Streams | Specifications |
|---------------------|-----------------------|--------------------|-------------------------|-----------------------|
|---------------------|-----------------------|--------------------|-------------------------|-----------------------|

| | | | | |
|-------|------------------------------|---------------------------------------------------|----------|--------------------------------------------------------------------------------------------------------------------------------------------------------------------------------------------------------------------------------------------------------------------------|
| E-501 | Heat Exchanger | Preheat Inlet Hydrogen | 15A, 15B | Steam Temperature: 153°C Steam Flow Rate: 1050 kmol/hr Heat Duty: 11.6 MW Heat Exchanging Area: 503 m ² |
| E-502 | | LP Steam Generation | 16A, 16B | Water Temperature: 30°C Water Pressure: 5 bar Steam Temperature: 162°C Steam Pressure: 5 bar Steam Flow Rate: 3700 kmol/hr Tubes: 2,460 Tube Length: 4.95 m Tube Diameter: 0.02 m Heat Duty: 52.4 MW Heat Exchanging Area: 892 m ² |
| E-503 | | LP Steam Generation | 16B, 16C | Water Temperature: 30°C Water Pressure: 4 bar Steam Temperature: 143°C Steam Pressure: 4 bar Steam Flow Rate: 3,678 kmol/hr Heat Duty: 48.1 MW |
| E-603 | | Preheat Recycle Stream | 22A, 22B | Steam Temperature: 151°C Steam Flow Rate: 400 kmol/hr Heat Duty: 4.4 MW Heat Exchanging Area: 190 m ² |
| C-501 | Multistage Compressor System | Raises Inlet CO ₂ Pressure to 10.1 Bar | 13, 14 | Duty: 19.9 MW |

| | | | | |
|-------|------------|-----------------------------------------------------|-------------------|----------------------------------------------------------------------------------------------------------------------------------------------------------------------------------------------------------------------|
| R-501 | Reactor | Heterogeneous Packed Bed Reactor, Syngas Production | 14, 15B, 16A, 22B | Temperature: 500°C Pressure: 10.1 bar Pressure Drop: 0.019 bar Reactor Volume: 61 m ³ Residence Time: 1.68 s Tubes: 481 Tube Diameter: 0.2 m Tube Length: 4 m Heat Duty: 60.32 MW |
| F-501 | Flash Drum | Removes Excess Water | 16C, 16D, 17 | Temperature: 35°C Pressure: 8.1 bar Heat Duty: 0 |

Methanol Synthesis Reactor

This block involves the production of methanol using the CO and CO₂ syngas from the reverse water gas shift reactor. A flash drum separates unreacted syngas and methanol. The unreacted syngas is recycled back to the reverse water gas shift reactor, while methanol is sent to further purification. This block consists of three heat exchangers, one flash drum, one packed bed reactor, and one compressor. A summary of required equipment, design specifications, and relevant streams is provided below.

Table 7.1-6 Equipment Summary for Methanol Synthesis Reactor

| Equipment ID | Equipment Type | Description | Relevant Streams | Specifications |
|---------------------|-----------------------|-----------------------------|-------------------------|---------------------------------------------------------------------------------------------------------------------------------------|
| E-504 & C-601 | Compressor System | Compresses Syngas to 30 Bar | 16D, 19A, 19B | Duty: 25.6 MW |
| E-601 | | LP Steam Generation | 20A, 20B | Water Temperature: 30°C Water Pressure: 5 bar Steam Temperature: 166°C Steam Pressure: 5 bar Steam Flow Rate: 530 kmol/hr |

| | | | | |
|-------|----------------|-------------------------------------------------------|-------------|---------------------------------------------------------------------------------------------------------------------------------------------------------------------------------------------------------------------------------------------|
| | Heat Exchanger | | | <p>Tubes: 600 Tube Length: 3.65 m Tube Diameter: 0.02 m Heat Duty: 7.6 MW Heat Exchanging Area: 109 m²</p> |
| E-602 | | LP Steam Generation | 20B, 20C | <p>Water Temperature: 30°C Water Pressure: 1.4 bar Steam Temperature: 110°C Steam Pressure: 1.4 bar Steam Flow Rate: 3,678 kmol/hr Heat Duty: 27.2 MW</p> |
| R-601 | Reactor | Heterogeneous Packed Bed Reactor, Methanol Production | 19B, 20A | <p>Temperature: 250°C Pressure: 30.4 bar Pressure Drop: 0.001 bar Reactor Volume: 236 m³ Residence Time: 43 s Tubes: 1,072 Tube Diameter: 0.2 m Tube Length: 7 m Heat Duty: 36.54 MW</p> |
| F-601 | Flash Drum | Separates Syngas and Methanol, Recycles Syngas | 20C, 21, 23 | <p>Temperature: 35°C Pressure: 8.1 bar Heat Duty: 0</p> |

Distillation Column

This block has a distillation column that purifies methanol to target purity.

Table 7.1-7 Equipment Summary for Distillation Column

| Equipment ID | Equipment Type | Description | Relevant Streams | Specifications |
|--------------|----------------|-------------|------------------|----------------|
|--------------|----------------|-------------|------------------|----------------|

| | | | | |
|-------|--------------------------------------|-----------------------|------------|-------------------------------------------------------------------------------------------------------------------------------------------------------------------------------|
| R-701 | Sieve Tray Distillation Column | Methanol Purification | 23, 24, 25 | Column Height: 40 m Column Diameter: 6 m Stages: 20 Feed Stage: 18 Reflux Ratio: 0.91 Boil Up ratio: 9.07 Condenser Duty: 44.5 MW Reboiler Duty: 47.2 MW |
|-------|--------------------------------------|-----------------------|------------|-------------------------------------------------------------------------------------------------------------------------------------------------------------------------------|

VIII. CONCLUSION AND FUTURE RECOMMENDATIONS

8.1 Conclusion

Direct air capture is a revolutionary new technology that can be utilized to combat the ever-growing threat of climate change. In this report, we have shown one of the countless ways that DAC can be used, not only to capture greenhouse gasses, but also to synthesize a usable product from said gas. Using the DAC and the methanol synthesis process described in detail in this report, the technology can have a positive outlook. However, also shown throughout this report is the economic drawbacks. The economic feasibility is not quite there yet, as the price of raw materials needed outweighs the revenue that can be generated from the products. Thus, until new developments can occur, this project cannot be recommended for construction. The three scenarios offered show that there are ways to start working towards a more feasible design, however there are still many uncertainties even in these theoretical scenarios. This report shows that a serious consideration of these scenarios must be taken into account if an economically viable design were to be pursued.

8.2 Future Recommendations

In regards to the DAC aspect of this system, innovations are still being made to increase the cost efficiency of removing ambient carbon dioxide from the atmosphere. In terms of this project, there is room for optimization in many aspects of the design. In the simulation of the air contactor, the inclusion of fans and a more detailed ASPEN design which includes the air contactor basin itself would provide more details on the energy consumption and reaction kinetics for this equipment. The pellet reactor and slaker should be modeled as a fluidized-bed reactors in the future

to give a more accurate description of their systems including energy consumption, CaO consumption, and other necessary details. A recommendation for the calciner system is to heat the dryer using heat from the combustion reactor instead of heating with electricity. This alone would not reduce electricity costs enough to make our system economically viable, but would make the system more efficient. The heat exchangers in ASPEN were also not fully designed to limit the scope of the report, but fully designing these would give a better estimate on their true heat efficiency. In addition to reconfiguring the slaker's ASPEN simulation, a reaction process should be developed that allows the slaker to operate at a lower pressure similar to the air contactor and pellet reactor to reduce the cost of the system and the need for valves to lower the pressure of the outgoing slurry mixture.

A gas purge stream is added to the methanol synthesis part in this design. The purpose of this stream is to prevent oxygen and nitrogen building up in the system. However, a significant amount of hydrogen is wasted in this stream, adding to the economic hardship of this project. In the future, the purge stream could be moved to the DAC block to prevent hydrogen losses.

IX. ACKNOWLEDGEMENT

Our Capstone group would like to acknowledge and give thanks to everyone who has helped us along the way to completing this project. We would like to give special recognition to Professor Eric Anderson, the advisor for this project, for his dedication to our development and knowledge when we had questions. We would like to give thanks to our own advisors for helping us through the difficult waters of the chemical engineering degree path, and to the Department of Chemical Engineering as a whole for their support to their students. Furthermore, we would like to acknowledge and thank the Carbon Capture and Conversion Capstone group of 2022, Rebeca Brown, Lillian Huynh, Pyung Lee, Alex Park, and Ciara Smith for the aid received both directly via questions, and indirectly through our group building upon their work. Lastly, we would like to thank Carbon Engineering for their leading role in a new field that shows great progress, and their research that serves as a strong basis for the design we have developed.

X. REFERENCES

- Ashurst, J., & Nappe, T. (2022). *Methanol Toxicity*.
<https://www.ncbi.nlm.nih.gov/books/NBK482121/>
- Bianchi, S. (2018). *Process modelling of a Direct Air Capture (DAC) system based on the Kraft process* [Masters Thesis, POLITECNICO DI TORINO].
<https://webthesis.biblio.polito.it/9262/1/tesi.pdf>
- Budinis, S. (2022). *Direct Air Capture* [Technology deep dive].
<https://www.iea.org/reports/direct-air-capture>
- Carbon Engineering. (2023). *Carbon Engineering*. <https://carbonengineering.com/>
- Centers for Disease Control and Prevention. (2023). *Carbon Monoxide Poisoning FAQ's*.
<https://www.cdc.gov/co/faqs.htm#:~:text=What%20are%20the%20symptoms%20of,pass%20out%20or%20kill%20you>
- Curl, R. L. (1980). The effectiveness of solid-solid heat exchange systems using an intermediate fluid medium. *Alternative Energy Sources; (United States)*, 5, Article CONF-801210-.
<https://www.osti.gov/biblio/6818728>
- IEA. (2022). *Investment tax credit for carbon capture, utilisation and storage (CCUS)*.
<https://www.iea.org/policies/13346-investment-tax-credit-for-carbon-capture-utilisation-and-storage-ccus>
- Industrial Water Rates | Fredericksburg, TX - Official Website*. (n.d.). Retrieved March 17, 2023, from <https://www.fbgtx.org/673/Industrial-Water-Rates>
- Joo, O.-S., & Jung, K.-D. (n.d.). Stability of ZnAEQ Catalyst for Reverse-Water-Gas-Shift Reaction (RWGSR). *Bulletin of the Korean Chemical Society*, 24(1), 86–90.
<https://doi.org/10.5012/bkcs.2003.24.1.086>

- Joo, O.-S., Jung, K.-D., Moon, I., Rozovskii, A. Ya., Lin, G. I., Han, S.-H., & Uhm, S.-J. (1999). Carbon Dioxide Hydrogenation To Form Methanol via a Reverse-Water-Gas-Shift Reaction (the CAMERE Process). *Industrial & Engineering Chemistry Research*, 38(5), 1808–1812. <https://doi.org/10.1021/ie9806848>
- Keith, D. W., Holmes, G., St. Angelo, D., & Heidel, K. (2018). A Process for Capturing CO₂ from the Atmosphere. *Joule*, 2(8), 1573–1594. <https://doi.org/10.1016/j.joule.2018.05.006>
- Kilkiş, B. (1988). Gas-Solid Heat Exchangers. In S. Kakaç, A. E. Bergles, & E. O. Fernandes (Eds.), *Two-Phase Flow Heat Exchangers: Thermal-Hydraulic Fundamentals and Design* (pp. 993–1030). Springer Netherlands. https://doi.org/10.1007/978-94-009-2790-2_32
- Marinitsch, G. (2021, August 3). *Bulk Solids Heat Transfer and Opportunities for Waste-Heat Recovery*. Process Heating. <https://www.process-heating.com/articles/93754-bulk-solids-heat-transfer-and-opportunities-for-waste-heat-recovery>
- Monsen, J. (n.d.). *Part I: A Guide to Control Valves and Process Variability | Valin*. Retrieved March 21, 2023, from <https://www.valin.com/resources/articles/part-i-guide-control-valves-and-process-variability>
- Ott, J., Gronemann, V., Pontzen, F., Fiedler, E., Grossmann, G., Kersebohm, D. B., Weiss, G., & Witte, C. (2012). Methanol. In *Ullmann's Encyclopedia of Industrial Chemistry*. John Wiley & Sons, Ltd. https://doi.org/10.1002/14356007.a16_465.pub3
- Ozin, G. (2022). *Direct air capture: A little history*. <https://www.advancedsciencenews.com/direct-air-capture-a-little->

history/#:~:text=In%201999%2C%20Klaus%20Lackner%2C%20a,means%20of%20ameliorating%20climate%20change

Ströhle, J., Hofmann, C., Greco-Coppi, M., & Epple, B. (2021). *CO 2 CAPTURE FROM LIME AND CEMENT PLANTS USING AN INDIRECTLY HEATED CARBONATE LOOPING PROCESS – THE ANICA PROJECT*. <https://www.semanticscholar.org/paper/CO-2-CAPTURE-FROM-LIME-AND-CEMENT-PLANTS-USING-AN-%E2%80%93-Str%C3%B6hle-Hofmann/5b4a2c65ea6924574d5b15e6b80ad59f9bc7a89d>

Tang, C. M. (2015). *Permian Basin*. <https://www.britannica.com/place/Permian-Basin/additional-info#history>

TheChemicalCompany. (2023). *Methanol*.

<https://thechemco.com/chemical/methanol/#:~:text=However%2C%20pure%20methanol%20wasn%27t,its%20elemental%20composition%20in%201834>

Turton, R. (2018). *Analysis, synthesis, and design of chemical processes*. (5th ed.). Pearson.

U.S. Bureau of Labor Statistics. (2022). *Chemical Plant and System Operators*.

Veloo, P. S., & Quintiere, J. G. (2013). Convective heat transfer coefficient in compartment fires. *Journal of Fire Sciences*, 31(5), 410–423.
<https://doi.org/10.1177/0734904113479001>

Verrett, J., Qiao, R., & Barghout, R. (2020). *Foundations of Chemical and Biological Engineering I*. <https://pressbooks.bccampus.ca/chbe220/>

XI. APPENDIX

CO₂ Direct Air Capture Process Stream Table (kmol/hr)

| | 1 | 2 | 3 | 4 | 5A | 5B | 6 | 7A | 7B | 8 | 9A | 9B | 10 | 11 | 12 | 13 |
|------------------------------------|-----------|-----------|---------|---------|---------|---------|---------|--------|--------|--------|--------|--------|---------|---------|--------|--------|
| CO₂ | 4118.5 | 451.8 | 0.0 | 0.0 | 0.0 | 0.0 | 0.0 | 0.0 | 0.0 | 4033.4 | 0.0 | 0.0 | 0.0 | 0.0 | 4033.4 | 4033.4 |
| O₂ | 2171288.4 | 2171323.6 | 56.5 | 56.5 | 56.5 | 56.5 | 0.0 | 56.5 | 56.5 | 56.5 | 0.0 | 0.0 | 0.0 | 0.0 | 56.5 | 56.5 |
| N₂ | 8191412.5 | 8194465.6 | 62.7 | 62.7 | 62.7 | 62.7 | 0.0 | 62.7 | 62.7 | 62.7 | 0.0 | 0.0 | 0.0 | 0.0 | 62.7 | 62.7 |
| KOH | 0.0 | 0.0 | 0.0 | 8066.7 | 0.0 | 0.0 | 0.0 | 0.0 | 0.0 | 0.0 | 0.0 | 0.0 | 0.0 | 0.0 | 0.0 | 0.0 |
| K₂CO₃ | 0.0 | 0.0 | 4033.4 | 0.0 | 0.0 | 0.0 | 0.0 | 0.0 | 0.0 | 0.0 | 0.0 | 0.0 | 0.0 | 0.0 | 0.0 | 0.0 |
| CaCO₃ | 0.0 | 0.0 | 0.0 | 0.0 | 4033.4 | 4033.4 | 0.0 | 4033.4 | 4033.4 | 0.0 | 0.0 | 0.0 | 0.0 | 0.0 | 0.0 | 0.0 |
| CaO | 0.0 | 0.0 | 0.0 | 0.0 | 0.0 | 0.0 | 0.0 | 0.0 | 0.0 | 4033.4 | 4033.4 | 4033.4 | 0.0 | 0.0 | 0.0 | 0.0 |
| Ca(OH)₂ | 0.0 | 0.0 | 0.0 | 0.0 | 0.0 | 0.0 | 0.0 | 0.0 | 0.0 | 0.0 | 0.0 | 0.0 | 4033.4 | 4033.4 | 0.0 | 0.0 |
| H₂O | 164381.2 | 175930.5 | 89634.6 | 89634.0 | 13445.2 | 13445.2 | 13445.2 | 0.0 | 0.0 | 0.0 | 0.0 | 0.0 | 13444.6 | 13444.6 | 0.0 | 0.0 |

Methanol Synthesis Process Stream Table (kmol/hr)

| | 13 | 14 | 15A | 15B | 16A | 16B | 16C | 16D | 17 | 18 | 19A | 19B | 20A | 20B | 20C | 21 | 22A | 22B | 23 | 24 | 25 |
|------------------|--------|--------|---------|---------|--------|--------|--------|--------|--------|--------|--------|--------|--------|--------|--------|--------|--------|--------|--------|--------|-------|
| CO ₂ | 4033.4 | 4033.4 | 0.0 | 0.0 | 1573.0 | 1573.0 | 1573.0 | 1573.0 | 0.0 | 301.7 | 1573.0 | 1573.0 | 1206.9 | 1206.9 | 1206.9 | 1206.9 | 905.2 | 905.2 | 0.0 | 0.0 | 0.0 |
| O ₂ | 56.5 | 56.5 | 0.0 | 0.0 | 0.0 | 0.0 | 0.0 | 0.0 | 0.0 | 0.0 | 0.0 | 0.0 | 0.0 | 0.0 | 0.0 | 0.0 | 0.0 | 0.0 | 0.0 | 0.0 | 0.0 |
| N ₂ | 62.7 | 62.7 | 0.0 | 0.0 | 103.4 | 103.4 | 103.4 | 103.4 | 0.0 | 22.0 | 103.4 | 103.4 | 103.4 | 103.4 | 103.4 | 103.4 | 40.7 | 40.7 | 0.0 | 0.0 | 0.0 |
| CO | 0.0 | 0.0 | 0.0 | 0.0 | 2460.4 | 2460.4 | 2460.4 | 2460.4 | 0.0 | 80.0 | 2460.4 | 2460.4 | 319.8 | 319.8 | 319.8 | 319.8 | 239.9 | 239.9 | 0.0 | 0.0 | 0.0 |
| H ₂ O | 0.0 | 0.0 | 0.0 | 0.0 | 2573.3 | 2573.3 | 2573.3 | 102.9 | 2470.4 | 5.9 | 102.9 | 102.9 | 469.0 | 469.0 | 469.0 | 23.5 | 17.6 | 17.6 | 445.6 | 9.5 | 436.1 |
| H ₂ | 0.0 | 0.0 | 12100.1 | 12100.1 | 9526.8 | 9526.8 | 9526.8 | 9526.8 | 0.0 | 1036.9 | 9526.8 | 9526.8 | 4147.5 | 4147.5 | 4147.5 | 4147.5 | 3110.6 | 3110.6 | 0.0 | 0.0 | 0.0 |
| methanol | 0.0 | 0.0 | 0.0 | 0.0 | 94.0 | 94.0 | 94.0 | 84.6 | 9.4 | 31.3 | 84.6 | 84.6 | 2506.6 | 2506.6 | 2506.6 | 125.3 | 94.0 | 94.0 | 2381.3 | 2357.5 | 23.8 |
| DME | 0.0 | 0.0 | 0.0 | 0.0 | 0.0 | 0.0 | 0.0 | 0.0 | 0.0 | 0.0 | 0.0 | 0.0 | 2.9 | 2.9 | 2.9 | 0.0 | 0.0 | 0.0 | 2.9 | 2.9 | 0.0 |
| formates | 0.0 | 0.0 | 0.0 | 0.0 | 0.0 | 0.0 | 0.0 | 0.0 | 0.0 | 0.0 | 0.0 | 0.0 | 2.9 | 2.9 | 2.9 | 0.0 | 0.0 | 0.0 | 2.9 | 2.9 | 0.0 |
| ketones | 0.0 | 0.0 | 0.0 | 0.0 | 0.0 | 0.0 | 0.0 | 0.0 | 0.0 | 0.0 | 0.0 | 0.0 | 2.9 | 2.9 | 2.9 | 0.0 | 0.0 | 0.0 | 2.9 | 2.9 | 0.0 |