

# **Hypersonic Atmospheric Reentry Deceleration Experiment (HARD-E)**

A Technical Report submitted to the Department of Mechanical and Aerospace Engineering

Presented to the Faculty of the School of Engineering and Applied Science

University of Virginia • Charlottesville, Virginia

In Partial Fulfillment of the Requirements for the Degree

Bachelor of Science, School of Engineering

**Vincent Tate**

Spring, 2022

Technical Project Team Members

Emma Auld, Hannah Boyles, Taylor Chandler, Yulie Cheng, Carsten Connolly, Noah Dunn,  
Joshua Franklin, Samuel Goodkind, Amy Lee, Andrew Metro, Isaac Morrison, Charlie Osborne,  
Carlos Perez, and Micah Whitmire

On my honor as a University Student, I have neither given nor received unauthorized aid on this assignment as defined by the Honor Guidelines for Thesis-Related Assignments

Advisor

Christopher Goyne, Department of Mechanical and Aerospace Engineering

# Technical Report

## Table of Contents

Project Overview	2
Mission Concept and Architecture	3
System Requirements and Constraints	4
Conceptual Design	6
Communications Functional Team	6
Software and Avionics Functional Team	8
Power, Thermal, and Environment Functional Team	10
Attitude Determination and Control System (ADACS) and Orbits Functional Team	14
Structures and Integration Functional Team	18
Team Overview	21
Project Schedule	23
Project Budget	24
References	27
Appendices	29
Appendix I: Center of Mass Calculations	29
Appendix II: Center of Pressure Calculations	30
Appendix III: Early Simulation Data	31

## Project Overview

Hypersonic atmospheric flight, or movement at speeds greater than Mach 5, is inherently difficult to simulate or test. The extreme speeds invite many challenges such as thermal management, vehicle control, and high-pressure loads. In order to design hypersonic technologies, engineers need real-world tests where effective data is collected for future designs. This can be an expensive and time-consuming process, but using CubeSats as test vehicles may offer a cheaper solution. CubeSats are miniature satellites that are usually secondary payloads on space missions and are composed of 10 by 10 by 10 centimeter cubes that are each 1 “U.” This project aims to use a 3U CubeSat with a blunt leading edge that will gather data during its reentry into the Earth’s atmosphere at hypersonic speeds. The CubeSat will spend time in extreme low Earth orbit before decelerating through the atmosphere and gathering valuable hypersonic regime data. The overall goal of the project is to assess the feasibility of using a CubeSat to study the conditions experienced by spacecraft decelerating from hypersonic speeds. This experiment has three primary objectives:

1. Successfully launching and deploying the CubeSat into extreme low Earth orbit
2. Successfully collecting and relaying hypersonic regime data collected during atmospheric reentry
3. Ensuring that the vehicle does not burn up before collecting and relaying at least 10 minutes of atmospheric reentry data while also ensuring that the vehicle completely burns up prior to reaching the Earth’s surface

To begin, the project team desires the CubeSat to successfully enter extreme low Earth orbit after separating from the launch vehicle that takes it to space. This involves not only launch vehicle success, but also that the CubeSat will be properly dispensed from the vehicle and will successfully enter its appropriate orbit. When the CubeSat is reentering the atmosphere, it is necessary to ensure that the CubeSat collects meaningful flight data at hypersonic speeds and is able to relay the information back to the ground station. Once a certain amount of data is collected and relayed, the CubeSat will need to experience thermal failure and burn up before reaching the surface of the Earth. This means that the CubeSat will need to be able to survive the conditions of atmospheric reentry briefly, but not long enough for it to become a projectile that endangers the Earth’s surface.

As a space faring organization, the National Aeronautics and Space Administration (NASA) has dealt with many instances of its technology reentering the Earth’s atmosphere in extreme conditions. One of the most important types of reentry is manned missions with blunt-shaped capsules equipped with heat shields that help to keep the crew safe while the capsule decelerates. Our CubeSat design draws from the capsule design by having a blunt heat shield to help keep its instruments safe during reentry. This experiment also aligns with the conditions experienced most frequently by NASA technologies when entering the atmosphere at orbital velocity. While there are many man-made devices that are capable of moving objects at speeds over Mach 5, atmospheric reentry is one of the only times where man-made devices move through the atmosphere at speeds over Mach 20. With this being such an extreme state to achieve, having a relatively inexpensive and reliable method by which to gather data at these speeds would allow for increased advancements in atmospheric reentry technologies. On top of the benefits that could directly be derived from this CubeSat experiment, there will also be the

added value of increased educational interest in hypersonics, aerodynamics, and the space mission process.

The US Department of Defense (DoD) is accelerating research into hypersonic weapons systems, especially as other sovereign nations such as China and Russia have demonstrated advances in the field. Hypersonic weapon systems have enormous potential for both offensive and defensive applications, as hypersonic projectiles are extremely difficult to track or intercept. The high altitudes at which most hypersonic weapons function provide a large cushion between air ground-based defense systems and the projectiles they are tracking, making intercepting them very tough. While one of the Department of Defense's largest current problems is production of hypersonic products on a large scale, there is still more research to be done that could progress the program by offering insight into easier ways to manufacture the technology. This CubeSat experiment can serve as a cost-effective way to gather hypersonic data that can be used to move defense projects forward with new insights. Production problems could possibly be lightened if new data leads to discoveries of alternative manufacturing techniques that would allow for a better production method.

### **Mission Concept and Architecture**

The payload for this experiment is the array of temperature, pressure, and inertial measurement devices integrated with the CubeSat that will be used to collect data while the vehicle experiences hypersonic conditions. The shape of the vehicle itself is also an important factor as the blunt heat shield will help attain appropriate deceleration conditions. The heat shield will serve as a means by which to protect the rest of the vehicle from the worst of the heat and pressure that will be experienced during atmospheric reentry. The walls of the CubeSat will also be composed of a thermally protective material to protect the internal components from extraneous heat that is sent past the heat shield. At the aft end of the vehicle are four aerodynamic flaps that will act to stabilize the CubeSat upon initial entrance into the atmosphere, and they will also serve to maintain the orientation of the vehicle throughout the entire reentry process in an effort to keep the heat shield at the front of the craft.

This experiment will not work to design a CubeSat dispenser, but will instead make use of designs already proven to function with a 3U CubeSat. The CubeSat is designed to mechanically integrate with the canisterized satellite dispenser onboard the Northrop Grumman Antares launch vehicle, which will eject the CubeSat directly into extreme low Earth orbit. The Antares launch vehicle will launch from the Mid-Atlantic Regional Spaceport (MARS), and the CubeSat will be turned over to Northrop Grumman 30 days prior to the launch. According to Antares mission regulations, the CubeSat must wait 15 minutes after being dispensed into orbit before any active systems can come online. However, in order to ensure that aerodynamic flaps have the highest chance for correct deployment, the team will be applying for a waiver on this requirement. The flaps will be designed to fold out as soon as the CubeSat is dispensed from the Antares craft, and the other components would be able to come online then as well. Once dispensed, the CubeSat will remain in an extreme low Earth orbit trajectory approximately 180 to 250 kilometers above the Earth's surface, at the same inclination as the International Space Station, for two to seven days before encountering enough atmospheric drag to initiate complete atmospheric reentry. While in orbit, magnetic hysteresis material inside the CubeSat will slowly work to align the vehicle with the Earth's magnetic field, stabilizing it before its descent into the atmosphere.

The CubeSat communications will be run through the Iridium satellite network to ensure that it will be able to communicate with the ground station no matter where it is over the Earth’s surface. While the CubeSat is in extreme low Earth orbit, the ground station will regularly communicate with it for several reasons. First, we will need to ensure that the communications system is fully functional in terms of both its uplink and downlink capabilities. We will also ensure that all of the onboard systems and sensors are working properly and will get an understanding of the craft’s remaining battery power. When the CubeSat is actually going through the process of atmospheric reentry it will only send hypersonic sensor data to the Iridium network and not need to receive anything. The vehicle will continue to collect and transmit data until the thermal protection system fails and the craft burns up above the surface of the Earth due to the sustained extreme conditions. Once collected, the data will be processed by end users including the University of Virginia School of Engineering and Applied Sciences, NASA, the US DoD, Northrop Grumman, and any other stakeholders in the hypersonic research community.

**System Requirements and Constraints**

There are four main functional requirements that were devised in order to ensure that the experiment is able to achieve its goals. First, the CubeSat must be able to survive the generally extreme conditions that it will experience during its deorbit and atmospheric reentry for long enough to obtain useful hypersonic data. This means that the CubeSat will need to be capable of enduring extreme temperatures, forces, the ionizing effects of hypersonic travel, and anything else that it encounters. Next, the sensors that are used by the CubeSat must collect effective and purposeful data. The data should be able to be examined and analyzed with enough certainty to determine whether the experiment went according to plan or if the collected data does not make sense. The CubeSat must then be able to relay the data that it collected to the team of students working on the project and any other stakeholders involved in the experiment. There are many methods by which the data can be relayed, but it will be difficult to communicate with the CubeSat directly from the ground given the unknown orbital trajectory that it will follow. Lastly, the CubeSat must remain powered throughout the entire mission. This means that the CubeSat power system must be able to last 30 days in cold storage, two to seven days during launch and while in orbit, and then while reentering the atmosphere. This information can also be referred to in brief via Table 1.

**Table 1: System Functional Requirements**

ID	Requirement
F1	Survive extreme conditions of deorbit and reentry for as long as is necessary to obtain data (extreme high and low temperatures, forces up to 7.8g)
F2	CubeSat sensors collect effective and purposeful data that proves mission success or failure
F3	Have capability to return mission data to the University for study
F4	Remain powered through entire mission (5-7 Days)

There are also three main operational requirements that were decided upon in order to ensure the best chance of mission success. First, the CubeSat must be able to remain aerodynamically stable at hypersonic velocities during atmospheric reentry. This means that the CubeSat needs to be stable enough for the heat shield to remain as the leading point of the craft's path through the atmosphere during the entire atmospheric reentry portion of the mission to avoid premature burnup and ensure that the data collected is usable. Next, the CubeSat must be able to transmit data throughout the entire mission and must be able to receive data at least occasionally while in orbit. It will only need to receive data for routine check-ins from the ground station in order to ensure that everything is functioning properly, but it will need to transmit data both while in orbit and while reentering the atmosphere. Lastly, the CubeSat must minimize power consumption from avionics systems, sensors, computing systems, and communications equipment during its operation. This must occur while still fulfilling all other requirements, but it ensures that the CubeSat remains conservative with the amount of volume and power that it has at its disposal. This information can also be referred to in brief via Table 2.

**Table 2: System Operational Requirements**

ID	Requirement
O1	Maintain stability of CubeSat at hypersonic velocity during atmospheric reentry
O2	Directly or indirectly transmit and receive data throughout mission
O3	Minimize power consumption of avionics, sensors, and communications during operation while fulfilling requirements

Finally, there are five main constraints that were determined necessary for this experiment. First, the CubeSat must fit dimensionally within given constraints for the dispenser that will be used to release it from the launch vehicle. The general CubeSat dimensions may not exceed 100 by 100 by 300 millimeters and the total mass of the vehicle must not exceed six kilograms. The CubeSat must also be able to appropriately integrate with the CubeSat dispenser onboard the Antares launch vehicle second stage. This will be accomplished by adhering to CDS and Northrop Grumman constraints and guidelines. Next, the CubeSat and the entire experiment itself must be compliant with federal and international regulations. Some of the organizations whose policies must be obeyed are the FAA, FCC, NOAA, NASA, and international organizations with rules about possible spacecraft landings. The designs, components, and manufacturing techniques used during the production and operation of the CubeSat must be either commercially available off the shelf or available through current attainable manufacturing techniques. Lastly, the total cost of all CubeSat designs, components, and subscription costs that are part of the experiment must remain under \$100,000. This information can also be referred to in brief via Table 3.

**Table 3: System Constraints**

ID	Constraint
C1	3U CubeSat weight and dimension specifications as specified by CalPoly: 100 x 100 x 300 mm, maximum mass of 4000 grams.
C2	The CubeSat must integrate with the CubeSat dispenser by following constraints for exterior size/shape and connector rails (laid out in CDS)
C3	CubeSat must be compliant with federal regulations (FAA, NOAA, NASA)
C4	Material cost must stay under budget of \$100,000
C5	Availability of manufacturing techniques and commercial products for mission components

## Conceptual Design

### *Communications Functional Team*

The success of this mission is dependent on the ability of the satellite to communicate collected data back to the ground station. The following section outlines the proposed communications strategy to satisfy the subsystem level mission requirements and constraints shown in Table 4.

**Table 4: Communications System Requirements and Constraints**

ID	Requirement
F2-COM1	Communications system must have uplink capabilities
F3-COM2	Onboard computer must be able to store data passed from sensors and transmit it back to ground station from the satellites network
F4-COM3	Power consumption is consistent with the power budget
C1-COM4	Weight and size is consistent with the constraints of a 3U satellite
C3-COM5	Mission must obtain experimental radio license from the FCC, must comply with technical constraints set by FCC and cannot interfere with other systems
O2-COM6	Stored data will be transmitted first to satellite constellation and back to ground station
O2-COM7	Frequency consistent with satellite constellation
O3-COM8	Sensor data should be transmitting every couple of hours throughout orbit and every minute during reentry.

The internal communication system is composed of the transceiver (radio) and the antenna. These components are powered by the CubeSat battery and data will be transmitted to

the iridium satellite. The external communications system is illustrated in Figure 1. After a week-long orbital lifetime, the CubeSat will begin its descent into Earth’s atmosphere. The communications system will transmit hourly health updates to the ground station throughout the duration of the orbit. Data collection will begin after the craft has begun atmospheric re-entry. The team will be collecting temperature and pressure data recorded from the sensor and pushed through the internal communication system as the craft descends. The data will be transmitted at short bursts from the antenna at least six times per minute. From there the data is transmitted from the craft to an iridium constellation satellite within line of sight of the disension. From the iridium satellite the data is transmitted to an iridium ground station and then to the UVa ground station.

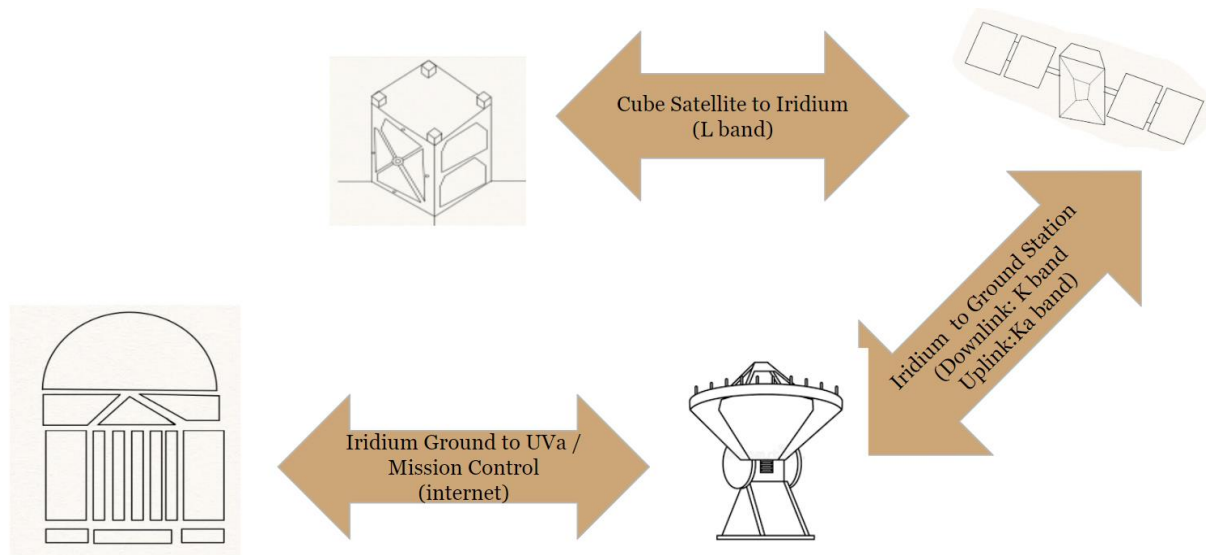

**Figure 1: Communications Flow Diagram**

In order to best satisfy the mission requirements, the Iridium core 9523 model was selected as the transceiver. The dimensions of this model are 70.44 by 36.04 by 14.6 mm and the model has a mass of 30.2 g. The small mass and size of this model allow it to satisfy C1-COM3. Additionally, it has uplink and downlink capabilities in the L band frequency (1.6 GHz) and the transmission rate is 0.35 - 0.44 kbits per second using Iridium’s Short Burst Data (SBD) service (Riot et al., 2021). By using data compression prior to transfer to the Iridium constellation and bursts of data being sent during atmospheric reentry, 350 - 440 bits of data transfer per second will be sufficient to relay 3 sets of temperature, 3 sets of pressure, and 1 inertial measurement data package collected by the CubeSat. From there, the Iridium constellation is capable of sending far more data per second to the ground station and mission control. Individual data values from sensors can be represented by only a few bits, and once mapped to a value and compressed by the on-board computer the antenna will be able to transmit many measurements per second. For example, 16 bits can represent numbers up to and over 65 thousand, so it will be up to future project teams to design and implement software that will allow the highest rate of data transmission from the 7 data-producing components. The 9523 model was selected over the lighter iridium 9602 model, mass of 11.4 grams, because the 9523 has previously been successfully tested in a CubeSat application (Riot et al., 2021). In this previous mission, the transceiver was able to connect with the Iridium constellation despite a worst-case scenario of a



significant tumbling rate of 20 degrees/sec. These results suggest that radio data will still be obtainable even in the event that aerodynamic stability is not achieved.

The selected antenna for this mission is the Taoglas Iridium patch antenna (part number IP.1621.25.4. A.02). This antenna was selected since it has been successfully used with the Iridium core 9523 transceiver in previous CubeSat missions (Riot et al., 2021). The operating temperature of the antenna is  $-40^{\circ}\text{C}$  to  $85^{\circ}\text{C}$ . During reentry, temperatures at the leading edge can reach 3000F. There will be a pressure differential from the leading edge to the tail. The communication equipment will be located in the coolest portion. In order to resist the high temperatures that the CubeSat will encounter during re-entry, the patch antenna will be mounted to the back of the spacecraft. Additionally, the antenna will be coated in a high heat resistant epoxy, such as Resbond 989 ceramic or McMaster-Carr high temperature silicone sealant. Once the transceiver has been purchased, different heat resistant materials should be tested in order to ensure that it does not interfere with the functionality. The antenna will interface with the radio using a connecting wire. The use of a shorter wire will minimize the losses and maximize the amplitude of the signal allowing for better communication.

After talks with Iridium, it is very possible that the project will be able to have free use of the subscription-based payment model that is usually employed by the satellite constellation company. The company is interested in working with educational institutions and the projects that their students are working on in order to increase interest in engineering and the aerospace industry. This arrangement would save the project team money and allow a closer relationship with the Iridium team that would make communications issues much easier to mend.

### ***Software and Avionics Functional Team***

The avionics system uses integrated modular avionics, with one central processor and a variety of peripherals providing sensor data to the CPU. Due to the passive nature of the attitude control system, the primary purpose of the CPU is to collect, store, and transmit the sensor data from the spacecraft to the communications system. The system will collect input data from the sensors, ground station, and release switches. It will store the data onboard for later transmission, and once an uplink with the Iridium network has been established, transmit the data to the communications system. Table 5 lists the requirements and constraints that guided the design of the software and avionics system.

**Table 5: Software and Avionics Requirements and Constraints**

ID	Requirement
F1-AV1	Electronics must remain fully functional in extreme environments
F2-AV2	Sensors must communicate with onboard computer
F3-AV3	Flight data needs to be able to be stored for transmission, which should be controlled by the flight computer
O3-AV4	Flight computer software needs to be able to control power modes
C5-AV5	Design should maximize the use of COTS components

In order to satisfy C5-AV5, a stack design using the PC 104 standard was selected, as it is easy to find commercial components for this standard and gives a higher radiation tolerance than a more dispersed design. The CPU chosen is the ISISpace ISIS OBC. To satisfy F1-AV1, the components chosen for the on-board computer and sensors must withstand the extreme temperatures of a hypersonic environment. The ISIS OBC has an operating temperature of -25 to +65 degrees Celsius, and coupled with the thermal insulation offered by the vehicle's thermal protection system the OBC should remain operational during the data collection period. The computer has extensive flight heritage, having been flown on many CubeSat missions since 2014, and comes equipped with a variety of communications protocols in order to interface with the spacecraft sensors. The computer is also reasonably priced, costing only \$5300 - about half of some other CubeSat CPUs.

The Kulite XCE - 080 model pressure transducer will be used to collect pressure data at three points: front, side, and back of the CubeSat. The pressure transducer was chosen with an operating range of -53 to 273 degrees Celsius to satisfy F1-AV1 – the electronics must be operational in a hypersonic environment. The output of the pressure transducer will be read using an Analog to Digital converter from Maximum Integrated; the MAX1415 integrated chip interfaces with the OBC through SPI, which the ISIS OBC supports. Lastly, the pressure sensor is a COTS component, which lowers the overall price of the part. Alternative options for the pressure sensor were a Pirani MEMS sensor that was formerly used on an atmospheric re-entry test from Purdue University (Goggin et al., 2017). Additionally, the Kulite XQE - 080 sensor was considered as it was proposed in a hypersonic CubeSat mission from the University of Minnesota (Anderson, 2021). However, the maximum operating temperature of both sensors was less than the Kulite XCE - 080 sensor.

The temperature sensors will measure surface temperature; a thermal plug in the nose of the CubeSat will consist of a copper rod, where self-adhesive thermocouples will be attached at the end to measure surface temperature. Two other locations of data collection are at the side and back of the CubeSat, where the thermocouple will be placed on the panels of the CubeSat. The Self-Adhesive Polyimide Fast Response Surface Thermocouples from OMEGA were chosen for their high operating temperature – 0 to 315 degrees Celsius – to satisfy F1-AV1. To read data from the thermocouples, the MAX 6675 digital converter will be used to read temperature data, using SPI interface, which is compatible with the ISIS OBC; thus, F2-AV2 is fulfilled. Lastly, the temperature sensor and convertor are commercially available components from OMEGA and Maximum Integrated, which lowers the cost of the components. Alternative design options were thermocouple probes, which would be placed into the nose of the CubeSat, however, the depth of the nose cone presented challenges to what probes could be used.

For the purposes of attitude determination, a Sensoror STIM377H IMU was selected. The STIM377H will be used to determine when stability is reached and to continuously verify the CubeSat's stability during atmospheric reentry through the examination of collected angular rates. Verification of the CubeSat's stability will facilitate the interpretation of other collected data, including temperature and pressure readings. Additionally, the IMU is capable of providing estimations of linear acceleration during reentry. In comparison to other potential IMUs, the STIM377H is characterized by a large range of operational temperatures (-40 to 85 degrees Celsius) and high shock and vibration resistance. Both the operating temperature and physical resistance contribute to the compliance of F1-AV1. The STIM377H is able to communicate with the selected OBC through the RS422 interface, satisfying F2-AV2. Other factors that contributed to the selection of the STIM377H include a relatively low mass and volume, a previously

established flight heritage in CubeSats, and a low bias due to linear acceleration, which is particularly important due to the deceleration that the CubeSat will experience during reentry.

Figure 2 demonstrates the general flow of both data and power through the CubeSat software and avionics, communications, and power storage and regulation components.

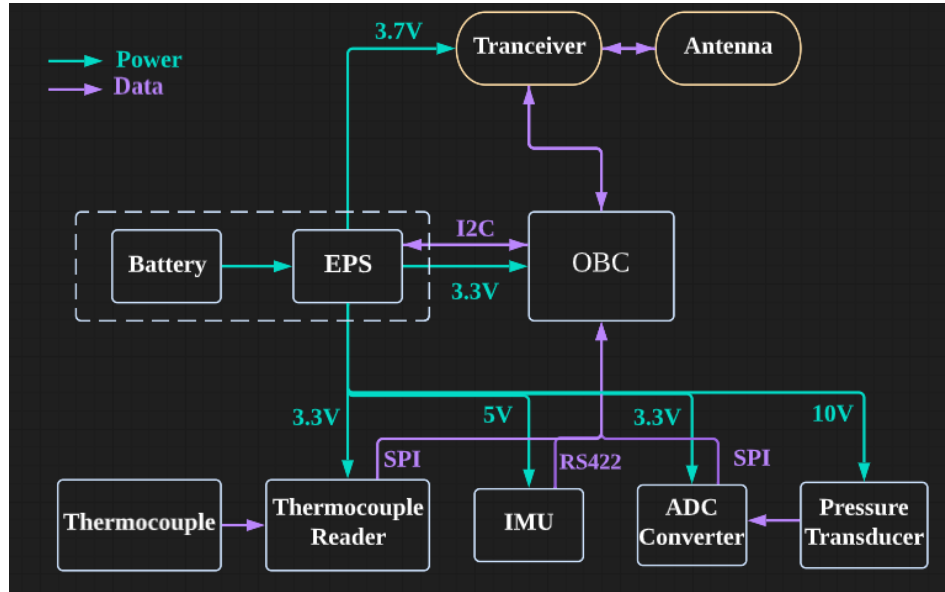

**Figure 2: Power and Data Flow Chart with Voltage Estimations and Relevant Interface Protocol**

### ***Power, Thermal, and Environment Functional Team***

The reentry vehicle will be constructed to have a complete burnup while also allowing for adequate data collection. This criterion will allow for mission success while also ensuring that the design meets the safety standards set by both NASA and the Antares hosted payload program. Table 6 lists the requirements and constraints that guided the design of the power, thermal, and environment functional team.

**Table 6: Power, Thermal, and Environment Requirements and Constraints**

ID	Requirement
F3-P2	Survive hypersonic flow conditions with external TPS until data transmission (~20 mins)
F4-P3	-Ensure battery can maintain charge while in storage before launch (maximum 4 months) -Ensure battery has sufficient charge to last throughout orbit and reentry (~1 week) -Ensure battery is durable enough to withstand hypersonic conditions and heating
O1-P4	External TPS is aerodynamically stable
O3-P5	Power consumption consistent with power budget
C1-P6	Account for TPS mass and density in final weight of CubeSat
C2-P7	Compact TPS within shape constraints of CubeSat
C3-P8	Ensure TPS protects spacecraft during experiment but then fails in order to allow burnup

Our design consists of a blunt, hemispherical heat shield constructed of phenolic cork and sheet polytetrafluoroethylene (Teflon) along the bus of the spacecraft. These materials will provide a great deal of durability to allow for significant data collection, while still ablating in time to prevent reentry survival. One of the main selection criteria for these materials was a low thermal conductivity, which would allow for a much cooler internal temperature compared to the surface temperature on the outside of the spacecraft. Cork and Teflon have thermal conductivities of 0.040-0.25 W/mK and 0.250 W/mK, respectively. These materials should provide sufficient insulation such that all electronics are able to function within their relevant operating temperatures. Another key criterion for the TPS was the ablation properties – Teflon and Cork both ablate and sublimate at temperatures lower than the maximum temperature of reentry, which will ensure a gradual burnup of the spacecraft. Other candidate materials our group considered were Inconel and ceramic wools due to their durability and thermal properties. However, Inconel proved to be too resilient and created the risk of unplanned spacecraft survival when used as the primary thermal protection system, and would not ablate in compliance with NASA requirements. However, Inconel is a suitable material for the main 3U frame that will be used to house the components of the CubeSat because the pieces are thin enough to melt once the primary thermal protection system gives way (Marlin, 2020). Ceramic wools were more expensive and less viable for an outer TPS. Therefore, Teflon and Phenolic Cork were selected as the primary materials for our TPS.

The TPS will enclose the entire spacecraft, protecting the interior components from the extreme temperatures for as long as possible to allow for maximum data collection and transmission. The combination of Teflon along the sides and phenolic cork at the nose will absorb and radiate the heat away, begin to ablate, and finally sublimate until total failure. These transitions will preserve the sensors, electronics, and transmitters for long enough to carry out the mission, collecting temperature and pressure data in hypersonic conditions. By dissipating the heat away, the TPS will keep the interior at a stable temperature during the testing window that does not surpass the maximum operating temperature for the components. A temperature vs position graph for a flight time of 3000s, holding the temperature at the nose constant at 3000 K, shows that the TPS size approximated for proper burnup provides more than enough protection over the lifespan of the mission in Figure 3.

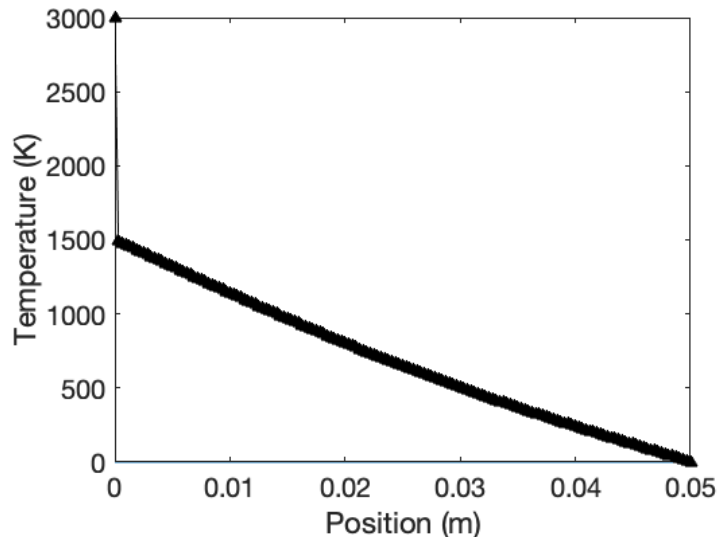

**Figure 3: Temperature vs. Position graph for CubeSat based on distance from front**

The proposed battery has been selected to ensure that each component in the design has the required power for operation while also limiting the mass consumed. The battery will need to hold a charge during the storage window, when the CubeSat is waiting for launch, and power components into a near-standby state during the launch and orbital window, the period where the CubeSat is orbiting in low Earth orbit before reentry. During the month leading up to launch, where the CubeSat is in storage, the Lithium-Ion battery will lose only about 10% of its total capacity (Battery University, 2021). During orbit, the battery will only be used for hourly “health checks” of its components and correspondence with the ground station. During the final phase of the experiment, the battery will supply power to the pressure and temperature sensors, the MCU, and the communication transmitters and antennae in order to collect data and safely transmit said data before burnup.

The Power System selected for our mission was the ISIS iEPS 45 W-h battery. This battery has been successfully utilized in previous missions, and comes from a reputable brand with a high-performance standard. Additionally, this battery has the added benefit of an integrated EPS, which will control the distribution of power and manage the discharge to the components. The EPS will also allow for the team to control the power remotely and utilize different power modes with various equipment turned on or off. Alternative power systems we considered were the SAFT 4S1P VES16 Battery and ClydeSpace Optimus 30. These batteries offered satisfactory performance and size characteristics for our mission, but did incorporate an EPS. To use these power systems would require a third-party EPS with no significant advantages in battery performance. For this reason, we have selected the iEPS with a 4 cell 45 W-h battery for our mission.

The power budget for this project was dictated by two main constraints: the 45 W-h available for use throughout the mission, and the 12.8 W maximum discharge. The maximum power draw will be 5.9 W when all the CubeSat systems are powered up during the testing window. This maximum load is about 46.1% of the battery’s maximum power capacity, and is being drawn from five major components on the Spacecraft. The power-drawing systems are the transceiver from the communications system, the IMU, ISIS OBC, three pressure sensors, and battery drain that occurs when the battery is powered on. The breakdown of these systems’ consumption is approximately half from the transceiver, one third from the IMU, and the rest is split similarly between the three pressure sensors and ISIS OBC. A more detailed breakdown is illustrated in Table 7 where the power budget is laid out by functional team consumption.

**Table 7: Power Budget**

Subsystem	Component (& number used)	Current (mA)	Voltage (V)	Power (W)	% Max Discharge
<b>Power</b>	Battery			0.1	0.78%
<b>Software</b>	Thermal sensors (x3)		na	na	na
	Pressure sensors (x3)		10	0.1	0.78%
	IMU (x1)		5	2	15.63%
	ISIS OBC (x1)		3.3	0.4	3.13%
<b>Communications</b>	Antenna	na	na	na	na
	Transceiver	500	3.2 - 6	3.1	24.22%
<b>Total</b>				<b>5.9</b>	<b>46.09%</b>
<b>Max Discharge</b>				<b>12.8</b>	

The next important topic in the power budget is how much of the 45 W-h battery's power is used at each stage of the mission. The battery will remain in storage for an estimated six months. Typically, battery drain during storage will be approximately 5% in the first 24 hours, and 2% every month thereafter. Over six months this will deplete 17% of the battery prior to the deployment of the spacecraft (Battery University, 2021). Six months is used here in order to provide a cushion for the energy requirements, despite the planned storage of the CubeSat only being roughly one month. After deployment, the battery can keep all systems online for around 380 minutes in total. Since all systems will be needed for the reentry testing, the power budget was planned with 20 minutes of full power reentry accounted for. This is around twice the time estimated for the reentry testing and should allow for as much collection as possible. The orbit prior to reentry is estimated to last between two and seven days. For this time period the spacecraft will power up and transmit for one minute every hour, which will use around one-third of the total available power if the CubeSat orbits for 7 days.

Under the prescribed conditions, the power consumption breakdown by phase is as follows: 17% during storage, 36.7% during a 7-day orbit, and 4.4% during reentry. This leaves an estimated 41.9% of the battery's power in reserve. These values are represented graphically below in Figure 4.

**Figure 4: Power Consumption by Mission Phase**

Figure 2: Power Consumption By Phase

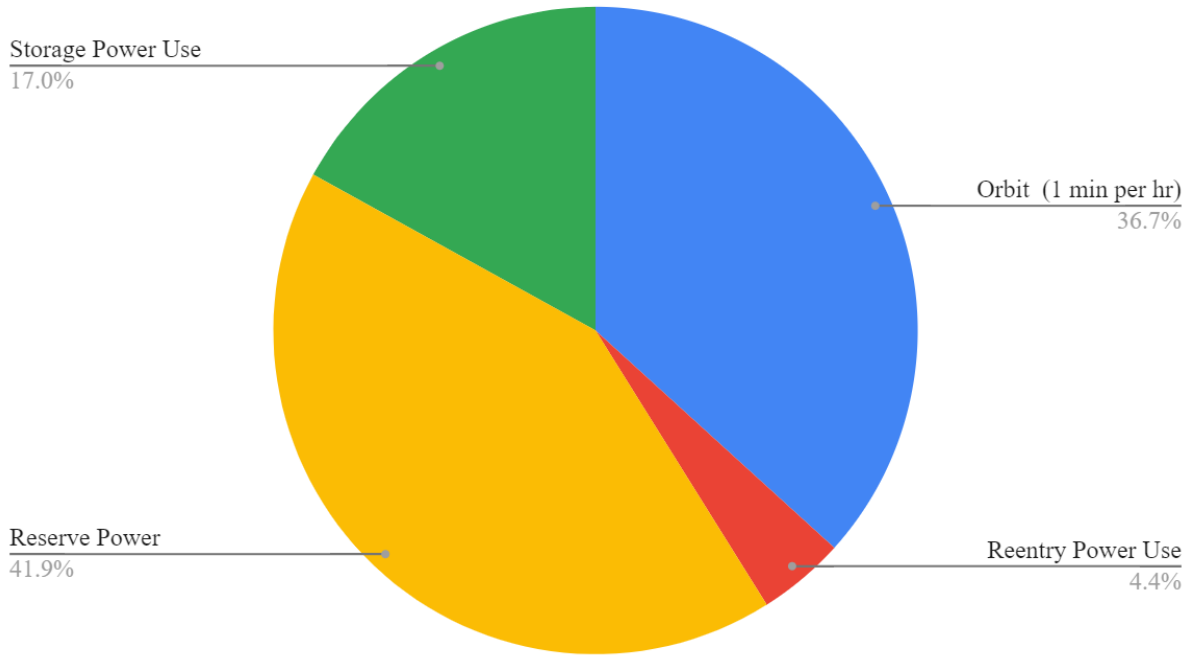

***Attitude Determination and Control System (ADACS) and Orbits Functional Team***

The success of this experiment will depend largely upon the ability of the reentry vehicle to orient itself correctly prior to reentry, so as to be in a position to collect meaningful data. The following section outlines the proposed strategies for attitude control of the reentry vehicle, keeping in mind the mass, power, and financial budgets. Table 8 lists the requirements and constraints that guided the design of the attitude determination and control system and orbits functional team.

**Table 8: Attitude Determination and Control System and Orbits Requirements and Constraints**

ID	Requirement
F1-CS1	Deformation and burnup of parts should not affect aerodynamic stability on reentry
F2-CS2	Attitude control, and knowledge will allow for accurate data to be collected
O1-CS3	Aerodynamic stability during data collection must prevent unwanted rotation ( $\pm 5^\circ$ )
C1-CS4	Blunt aerodynamic shape must fit with size and weight specifications
C2-CS5	Shape must fit in dispenser or change during flight to form a stable shape Rails can't interfere with aerodynamic stability
C5-CS6	Durability and shape depend on manufacturing techniques and availability

The final design for our aerodynamically stabilized and magnetically damped 3U CubeSat is made up of four 18-centimeter-long fins deployed at an angle of 160 degrees from the body of the CubeSat (20 degrees off of its plane), similar to what is shown in figure 5. Directly after deployment from the second stage of the Antares launch vehicle, hinged flaps will deploy through springs to begin the aerodynamic attitude correction. The aerodynamic attitude correction will be paired with magnetic damping through the use of passive magnetic damping by hysteresis material. The reasoning for how this design was chosen, as well as proof that the design is feasible, will be shown through previous projects that have used similar designs, and simulations for similar designs.

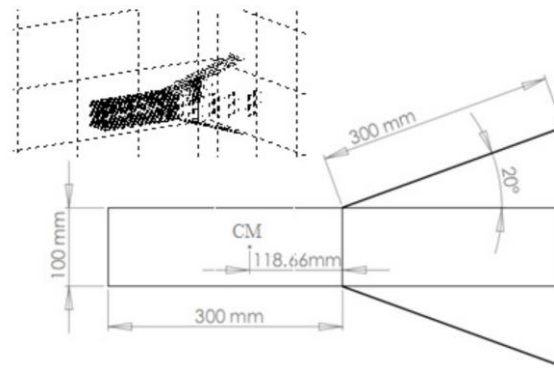

**Figure 5: Aerodynamic model for a 3U CubeSat with deployed side panels (Rawashdeh, 2010)**

In 1996, the Passive Aerodynamically Stabilized Magnetically-damped Satellite (PAMS) proved the feasibility of aerodynamic stabilization paired with magnetic hysteresis material for damping, for altitudes from 250 to 325 km (Kumar, et al., 1996; Kumar et al., 1995; Pacini and Skillman, 1995). This design was dimensionally similar to a 3U CubeSat, but the design was based on a large differential of weight between one end of the satellite and the other. This large offset between the center of mass and the geometric center can be utilized to create a gravity gradient that can provide torque to point the satellite in the nadir vector. In 2004, analysis by Psiaki found that a “shuttlecock” shape would supply aerodynamic stability for a 1U CubeSat, along with active magnetic torque coils for damping. This shuttlecock design implemented four-meter-long flaps deployed at  $12^\circ$  out the back. Rawashdeh (2013) describes an aerostabilized CubeSat design with the objective of recovering from the initial tumble and then achieve and maintain velocity vector alignment in steady-state condition. This design, as shown in the image above, includes four panels deployed out of the back of the satellite at an acute angle relative to the centerline of the satellite. Before deployment of the CubeSat the panels lay against the sides of the satellite, then are deployed to their acute angle behind the spacecraft shifting the center of mass slightly back, and shifting the center of pressure back further which will supply correcting torque to keep the attitude along the velocity vector. This aerostabilized CubeSat design is similar to the Pumpkin Inc. Colony-I CubeSat Bus and the QARMAN CubeSat designed by the Von Karman Institute, and this design will be used for our CubeSat.

Stability through aerodynamic design must be coupled with a form of angular rate damping. An aerodynamically stabilized satellite oscillates about the velocity vector, and without damping the satellite would oscillate endlessly as a pendulum would in a vacuum (Rawashdeh,



2010). This angular rate damping can be done magnetically through passive or active approaches. Magnetic hysteresis materials offer a lightweight and inexpensive passive damping system. A material with low coercivity and high permeability would be magnetized and demagnetized by the Earth's magnetic field which causes energy loss as the magnetic field flips in magnetic domains in the material (Rawashdeh, 2010). The selected hysteresis material for analysis is HyMu-80 and would be placed along the interior surface of the CubeSat along all three axes (X, Y, and Z) similar to the Colorado Student Space Weather Experiment that used magnetic attitude control (Gerhardt & Palo, 2010). Active damping can be done through magnetic torque coils, which counteract the angular momentum of the spacecraft. Active damping provides greater torque than passive systems, but also comes with tradeoffs such as power requirements and increased complexity and risk. Therefore, passive hysteresis damping is preferred if determined to be feasible.

The 3U CubeSat design with 10x30cm fins at 20° at an altitude of 380 km was simulated by Rawashdeh in 2013 using the Smart Nanosatellite Attitude Propagator (SNAP) to compare the detumbling by passive damping and active damping. The simulation includes models for gravity gradient torque, magnetic torque and damping, aerodynamic torques, and active magnetic control torques. Table 9 below shows the design parameters for the simulation, and Figures 6A and 6B show the attitude responses by the passive and active damping systems.

**Table 9: Magnetic Damping table for 3U CubeSat**

3U CubeSat, 10 cm x 30 cm fins deployed at 20°		
Design Type	Passive Damping Solution	Active Damping Solution
Orbit	380 km circular, 51.6° inclination	
Mass, Inertia (Ixx, Iyy, Izz) Drag Area	5 kg, (0.0109, 0.0664, 0.0664) kg m <sup>2</sup> 0.020261 m <sup>2</sup>	
Angular Rate Damping	Hysteresis: HyMu80 10.5 cm <sup>3</sup> (3.5 cm <sup>3</sup> per axis)	B-dot control 0.04 Am <sup>2</sup> three-axis Torque Coils, K = 18000
Simulation Parameters	10 °/second initial rate	
Results		
Detumbling Time	5 hours	20 hours
Steady-state Tracking Accuracy	15-20°	Below 0.1°

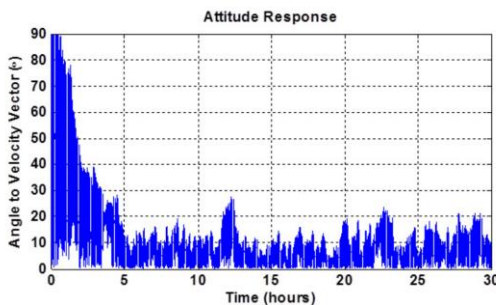

**Figure 6A: Passive Damping**

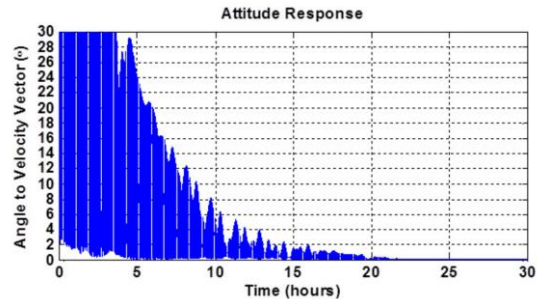

**Figure 6B: Active Damping**

This simulation proves the feasibility of using hysteresis material for passive damping within 10-20° at an altitude of 380 km. However, satellites at lower altitudes face much larger aerodynamic torques, which would require larger volumes of hysteresis materials. Therefore, more than 3.5 cm<sup>3</sup> per axis of the HyMu80 hysteresis material would be necessary. The low altitudes that data will be collected by the HARDE CubeSat may have aerodynamic forces too large for hysteresis materials to be used, which would mean active damping is required. Simulation using the SNAP software (Rawashdeh, 2019) for our CubeSat design at low altitudes was inconclusive, but it is likely that passive hysteresis damping will be sufficient to stabilize the satellite along the velocity vector with the help of damping from aerodynamic drag at the altitude that data will be recorded at (110-120 km). However, further simulations are required to determine, without a doubt, that aerodynamic stabilization and passive damping will stabilize the CubeSat sufficiently.

The specifications for potential components are compared below in Table 10. If an active stabilization is required, it is important to find magnetorquers that minimize power use and provide 3-axis stabilization so that damping could be supplied in all 3-axes. Mass was not as large of a constraint since there is space for additional mass in the mass budget, though power use is limited by the selected battery. The NanoAvionics MTQ3X provides 3-axis stabilization with the least amount of power use at a typical value of 0.4 W (NanoAvionics, 2022). The magnetorquer board would be integrated with the Sensoror STIM377H inertial measurement unit (IMU) that would supply input for actuation. However, IMUs have drift over time and would require pairing with another form of attitude sensing such as a magnetometer that measures the local magnetic field of Earth to provide estimates of attitude and orbital positions (NASA, 2020). The ZARM AMR magnetometer offers accurate pointing measurements for a relatively low cost of 0.3 W and less than 60 grams (SatCatalog). Combined, an active control system using the NanoAvionics MTQ3X magnetorquer board and the ZARM AMR magnetometer would take up 0.7 more Watts, around 115 more grams, and 169,680 mm<sup>3</sup> more area than passive hysteresis damping. There is enough room for the active system in the mass and power budget, but the passive hysteresis damping would be preferred due to its lower complexity and less energy use, mass, and volume.

**Table 10: Magnet Damping Options**

	<b>Energy (W)</b>	<b>Mass (g)</b>	<b>Size</b>	<b>Cost (\$)</b>
<b>NanoAvionics MTQ3X Magnetorquers</b>	0.4	205	94x96x17 mm = 153,408 mm <sup>3</sup>	N/A
<b>ZARM AMR Magnetometer</b>	<0.3	<60	56x36x17 mm = 34,272 mm <sup>3</sup>	N/A
<b>Magnetorquers + Magnetometer</b>	0.7	265	187,680 mm <sup>3</sup>	N/A

<b>Hysteresis (HyMu80)</b>	No power consumption	>150	>18,000 mm <sup>3</sup>	<\$100
----------------------------	----------------------	------	-------------------------	--------

The final recommendation for attitude control would be aerodynamic stabilization through the 18-centimeter-long fins deployed at 20 degrees up from straight behind the CubeSat chassis to provide torques to point the CubeSat along its velocity vector. The calculations for aerodynamic stabilization can be found in the following section as well as Appendices I and II. Passive damping is recommended using greater than 6 cm<sup>3</sup> of HyMu-80 along each axis of the CubeSat (X, Y, and Z) which is approximately 150 g. The Smart Nanosatellite Attitude Propagator (Rawashdeh, 2019) provides useful simulation for the attitude of a CubeSat accounting for the altitude, aerodynamic model, and amount of hysteresis material, but due to computing limitations and lack of knowledge of the satellites final inertia matrix simulations could not be done to verify passive damping without a doubt. Therefore, further simulation must be done to verify passive damping and, if necessary, the NanoAvionics MTQ3X magnetorquer board can be used for active damping with relatively low power use.

***Structures and Integration Functional Team***

The structures and integration functional team is responsible for the physical design of the CubeSat and the physical layout of its internal components. Table 11 lists the requirements and constraints that guided the design of the structures and integration functional team.

**Table 11: Structures and Integration Requirements and Constraints**

ID	Requirement
F1-S1	All components must be able to withstand extreme heat and pressure of reentry
F1-S2	Spacecraft must withstand launch of up to 7.8 g's (15.6g's during launch with factor of safety of 2)
F4-S3	Sensible layout for devices that secures electronics and electrical connections
O1-S4	Maintain integrity of aerodynamics
C1-S5	Adheres to mission constraints for mass and volume while meeting structural requirements
C3-S6	CubeSat structure must adhere to federal/international regulations
C5-S7	Spacecraft structure/design must consider the feasibility of manufacturing and materials

During the Conceptual design phase of this project, the Structures and Integration team created four potential CubeSat structure designs that are displayed in Figure 7. The designs were ranked against each other using a Design Decision Matrix based on reliability, cost, complexity, and aerodynamic stability which can be found in Table 12. Each candidate option was rated on a scale from 1-4 for each category, and the aggregate score was used to determine an optimal design.

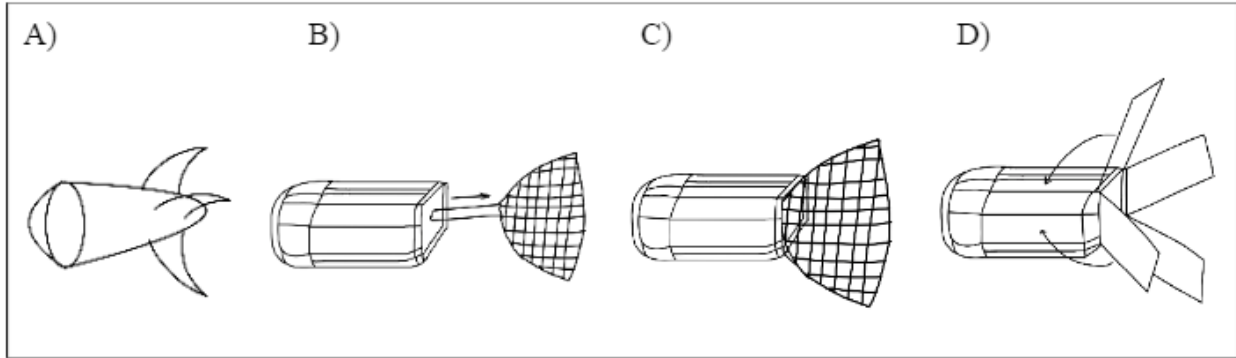

**Figure 7:** Sketches of Potential CubeSat Designs.

Design A consists of a singular solid piece with no moving parts once the CubeSat is launched, resulting in increased reliability. However, this design has decreased usable volume due to being nested inside the CubeSat. Design B consists of an extendable pole with a flexible metal net attached to the end. This design would have increased stability due to the inclusion of the net, however the pole limits the usable space and the net would likely melt. Design C is similar to Design B; however, a flexible metal net is directly attached to the rear of the CubeSat. Although this solves the issue of decreased usable space, the net would likely melt. Design D is the final chosen design as it had the highest aggregate score in the matrix. It consists of four spring-loaded panels spring-loaded to the side of the CubeSat that will be deployed upon launch to enhance aerodynamic stability. The panels are attached to the CubeSat via externally sculpted hinges attached to the rear of the craft. The structure will be made of inconel, an alloy that is able to withstand extremely high temperatures, and the sides of the flaps facing in the direction of the CubeSat’s motion through the atmosphere will be coated in Teflon for additional protection. Additionally, this design has a large usable volume.

**Table 12: Design Decision Matrix**

Design	Reliability (Less Risk)	Low Cost	Low Complexity	Aerodynamic Stability	Total
A	3	1	1	3	8
B	1	1.5	2	4	8.5
C	2	3.5	3	3.5	12
D	3.5	3	3.5	4	14

The maximum mass allotted for all components combined is 6 kilograms. The breakdown of the mass of each component is shown in Table 13.

**Table 13: Mass Budget**

Subsystem	Component (& number used)	Total Mass (kg)	% Actual Mass	Allocated % of Total Mass
<b>Structures</b>	Chassis	1.656	54.05%	55%
	Hinges	0.587		
	Lead Ballast	1.000		
<b>Power, Thermal</b>	iEPS Electrical Power System	0.365	10.55%	15%
	Cork (Heat Shield)	0.268		
<b>Software</b>	Thermal sensors (x3)	.003	2.58%	5%
	Pressure sensors (x3)	.003		
	Attitude Sensor	.055		
	ISIS OBC (x1)	0.094		
<b>ADACS</b>	Hysteresis Material (HyMu 80)	0.150	15.3%	5%
	Wings (x4)	0.768		
<b>Communications</b>	Iridium Core 9523 Transceiver	0.032	0.62%	5%
	Antenna	0.0056		
<b>Miscellaneous</b>	Wiring	0.150	10.83%	5%
	Other	0.500		
<b>Margin</b>		<b>0.3634</b>	<b>6.07%</b>	<b>10%</b>
<b>Total</b>		<b>5.6366</b>	<b>100%</b>	<b>100%</b>

Figures 8 and 9 below are two models of the layout of the internal components. Component placement focused on placing most components at the front of the CubeSat to enhance aerodynamic stability in addition to creating a sensible layout for devices that secures electronics and electric connections.

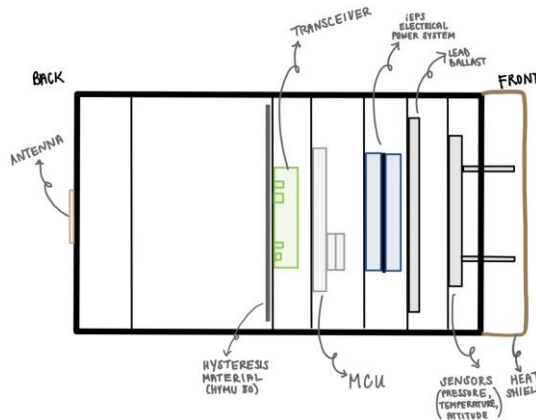

**Figure 8: Internal Component Layout**

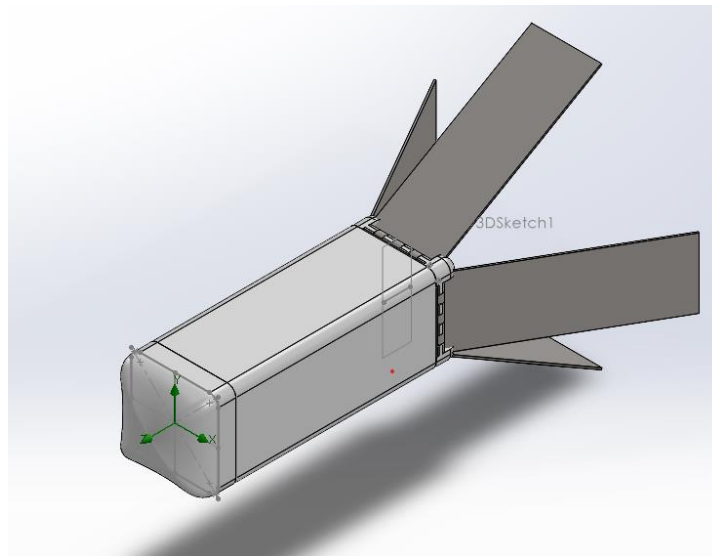

**Figure 9: SolidWorks Model**

The center of mass was calculated to be 17.76cm from the front of the CubeSat with the wings angled at 20 degrees, as shown in Appendix I. A kilogram of lead was added to the front of the CubeSat in order to move the center of mass up, and this was possible due to the project originally coming in solidly under the maximum mass. The center of pressure for the CubeSat body was calculated to be 20.695cm from the front of the CubeSat with the wings angled at 20 degrees, as shown in Appendix II. This was calculated by assuming the CubeSat would be traveling through the atmosphere at roughly Mach 20 and using a compressible aerodynamics calculator (Devenport, 2022). While the speeds of the vehicle may vary, the center of mass is likely to remain firmly in front of the center of pressure because the pressure differential between oblique and normal shock remains similar enough. Both the center of mass and center of pressure are located roughly in the center of the CubeSat with respect to the plane that is 10 by 10 centimeters along the length of the vehicle. The center of pressure being located behind the center of mass ensures that the CubeSat will be able to maintain aerodynamic stability along its trajectory through the atmosphere, with the ablative heat shield remaining at the front end of the vehicle.

In comparison to the passive attitude control studies detailed above by the ADACS and orbits functional team, which are primarily used in order to slowly stabilize the CubeSat while it is in orbit, the aerodynamic stabilization provided by the wings will be very powerful due to the extreme speeds that the vehicle will experience during atmospheric reentry - even at high altitudes where the atmosphere is thin. The passive attitude control will stabilize the CubeSat before it begins atmospheric reentry so that the aerodynamic design of the CubeSat will be able to go into effect with more ease. Once in the atmosphere, the forces experienced by the CubeSat will be too great for passive control, so aerodynamic pointing must come into effect.

## **Team Overview**

Our team is composed of 15 students in their final year of undergraduate study at the University of Virginia in Charlottesville, Virginia. On the team is a collection of prospective

mechanical and aerospace engineers working towards completing our capstone project for the UVA School of Engineering and Applied Sciences. The year-long capstone project and accompanying courses, overseen by Dr. Christopher Goyne, represents the collaborative efforts of a program manager and five functional teams with varying project focuses.

The program manager, Noah Dunn, helps to schedule deadlines for the team and ensure that each functional team is always on track to meet its goals. The program manager also works to establish clear lines of communication between the functional teams, outside subject matter experts, and Dr. Goyne. Finally, whenever any help is needed by members of a functional team, the manager is responsible for helping the members solve any problems. The communications functional team, including Hannah Boyles and Joshua Franklin, is responsible for the sourcing and design of all aspects of communication onboard the CubeSat. On top of ensuring that all necessary components for communication to and from the CubeSat are properly implemented and capable of meeting project requirements, members also coordinate with Iridium in order to attain the ability to use the satellite network. The software and avionics functional team, including Yulie Cheng, Samuel Goodkind, and Vincent Tate, is responsible for all of the computing and data collection needs of the CubeSat. They are in charge of the experiment's inertial measurement unit, thermocouples, and pressure gauges that all collect hypersonic data, as well as the computing system and software that allow this raw data to be communicated with the ground station. The power, thermal, and environment functional team, including Emma Auld, Andrew Metro, and Carlos Perez, is responsible for ensuring that the CubeSat is in the best possible position to survive the extreme conditions of atmospheric reentry. They are responsible for designing the ablative heat shield that will be used to protect the craft from the majority of the heat that it will experience during atmospheric reentry, and also for determining what materials are best suited for protecting the rest of the CubeSat. The functional team is also responsible for the power supply for the CubeSat in the form of its battery pack and electric power system. The attitude and determination and control system and orbits functional team, including Carsten Connolly, Charlie Osborne, and Micah Whitmire, is responsible for ensuring that the CubeSat remains aerodynamically stable while reentering the Earth's atmosphere. The team is also responsible for making use of passive magnetic damping with hysteresis material in order to stabilize the CubeSat during its time in extreme low Earth orbit. The structures and integration functional team, including Taylor Chandler, Amy Lee, and Isaac Morrison, is responsible for the design of the CubeSat itself. They work to design the chassis for the CubeSat that will house all of the other components while being able to mate with the CubeSat dispenser. The functional team works with the power, thermal, and environment team in order to implement the heat shield into the chassis design, as well as the attitude and determination and control system and orbits team in order to implement the folding aerodynamic flaps into the chassis design.

At the beginning of the capstone project in August and September of 2021, we learned the basics of the spacecraft design process and received our project: designing a blunt-nosed 3U CubeSat that would be launched into orbit and then collect data as it reentered the Earth's atmosphere at hypersonic speeds. The entire team has met twice weekly in class to brainstorm as a group, work within functional teams, or receive presentations from industry professionals since then. The team, as well as individual functional teams, have also met on many occasions outside of these designated times in order to develop progressive presentations, technical papers, and advanced designs. In September through October of 2021, our team met primarily as a whole in order to brainstorm the requirements and constraints that we would need in order to ensure our

mission success. In October through December of 2021, the team worked through multiple potential concepts for a CubeSat design that would meet all of our requirements and constraints. After iterating through multiple concepts and weighing pros and cons for each, a single potential design was settled upon. The team then wrote a paper detailing the specifications of the design that is now being used and prepared a presentation to go over the alternative concepts that were under consideration. In January and February of 2022, the team worked mostly at a functional team level while still maintaining group-wide communications. Candidate components and vendors were researched and functional team requirements and constraints were updated as was deemed necessary as new information came to light. A technical interchange meeting presentation was prepared in order to outline potential designs and components, and a schedule for the next steps in the process was laid out. From March until April of 2022, the team has narrowed down potential designs and components into one final, cohesive design that is able to meet all of the outlined requirements and constraints. The team is preparing for a conceptual design review that will cover the final design and all of its specifications in May of 2022.

For the 2022-2023 school year, the proposed team of students would be split into the same functional teams that it is split into this year in order to complete the in-depth preliminary and critical design reviews. For the 2023-2024 school year, the proposed team of students would be split into a fabrication team that focuses on building the CubeSat and a software team that focuses on ensuring the electronic systems of the CubeSat. These two teams will oversee CubeSat fabrication, testing, and the mission readiness review. Finally, for the 2024-2025 school year the proposed team of students would be split into a communications team that will focus on maintaining communications with the CubeSat and a data analysis team that will focus on analyzing the data received from the CubeSat during its mission.

## **Project Schedule**

Below in Table 14 is the proposed schedule for the completion of the HARDE project from April of 2022 through its deployment and collected data analysis in 2025. While there will likely be work completed multiple times a week throughout the duration of this schedule, only the key deliverables and milestones are named. This allows for brevity in terms of the physical schedule and flexibility for future project teams to exercise discretion on short term scheduling goals. For the remainder of our team's time with the project, we will focus primarily on the completion of chassis designs and component selection as we approach the project's conceptual design review. For the review, a full model of the system will be presented, and a 3D printed model of the entire CubeSat will be created.

Over the next three years, new teams of mechanical and aerospace engineers in their final year of undergraduate study at the University of Virginia will continue with the project in multiple stages. The group immediately following this one will focus on the spacecraft preliminary design review and critical design review so that the CubeSat will be entirely ready for construction. The following year will involve the assembly of the vehicle, the software development for its systems, and testing that will culminate in a mission readiness review. After this, the CubeSat will be ready for delivery to Northrop Grumman at the Mid-Atlantic Regional Spaceport, and shortly after it will complete its data-collection at hypersonic speeds as it reenters the Earth's atmosphere.



**Table 14: Project Schedule**

Task	2022			2023				2024				2025	
	Q2	Q3	Q4	Q1	Q2	Q3	Q4	Q1	Q2	Q3	Q4	Q1	Q2
Conceptual Design	■												
Conceptual Design Review	■												
Apply for FCC Radio License		■	■	■	■	■	■	■	■	■			
Preliminary Design Review		■	■										
Critical Design Review				■	■								
CubeSat Assembly						■	■						
Software Development						■	■						
Testing							■	■	■				
Mission Readiness Review									■				
Delivery to Launch Provider										■			
Launch and Orbital Operations										■			
Atmospheric Reentry										■			
Data Analysis										■	■	■	
Documentation												■	■
Final Mission Report													■

**Project Budget**

The total proposed budget for the HARDE mission is \$63,829. Below is a breakdown of this cost by commercial off the shelf component, manufactured component, or subscription as well as the functional team responsible for its selection.

**Table 15: Budget Breakdown**

<b>Functional Team</b>	<b>Component Name</b>	<b>Component Function and Description</b>	<b>Cost</b>
Structures and Integration	Chassis materials and printing	This includes the printed material for the main rectangular prism 3U frame and the internal plates that are used to mount components. It includes cutouts for where the aerodynamic flaps fold down, where the heat shield connects to the frame, and an aft port for the antenna. It also includes the cost of physically manufacturing the components.	~\$15,000
Power, Thermal, and Environment	Heat shield	The phenolic cork piece that is attached to the front end of the CubeSat chassis	\$56
Power, Thermal, and Environment	Teflon side panels	Teflon sheets lining the length of each side of the CubeSat to protect internal components from heat	\$52
Power, Thermal, and Environment	Battery with Power Regulator	45 Wh Lithium-Ion battery pack that will be used to power the CubeSat throughout the entire mission, and a voltage regulating electric power system that will disperse and control the flow of power from the battery to the other CubeSat components	\$9,250
Software and Avionics	Type K thermocouples (x3)	Thermocouples that will be used as temperature sensors for the CubeSat - one will measure the temperatures experienced by the craft at the heat shield, one will take measurements from midway between the front and back of the craft, and one will take measurements at the back of the craft next the CubeSat antenna	\$330
Software and Avionics	Thermocouple Reader (x3)	The thermocouple reader proposed from Maximum Integrated, MAX6675, will be used to read data collected from the thermocouples. The integrated chip costs \$16.42 per part.	\$50
Software and Avionics	Kulite Pressure Sensor XCE (x3)	Pressure sensors for the CubeSat - one will measure the pressures experienced by the craft at the heat shield, one will take measurements from midway between the front and back of the craft, and one will take measurements at the back of the craft next the CubeSat antenna	\$1,077
Software and Avionics	Analog to Digital Convertor (x3)	The ADC proposed will be used to read pressure sensor data, manufactured from Maximum Integrated. The ADC costs \$10.54 per part.	\$32
Software and Avionics	Inertial Measurement Unit	Device that will measure the CubeSat specific force and angular rate, providing data for the general orientation of the vehicle and acceleration	\$8,200
Software and Avionics	ISIS on board computer (OBC)	Acting as the brain of the CubeSat, the OBC is the main point of contact for all forms of data for the mission - it controls the flow of data from all sensors, the power system, and the communications system	\$5,300

ADACS and Orbits	Hysteresis Material	The magnetic material will be used to stabilize the CubeSat in orbit based on the Earth's magnetic field - it will aid in reducing tumbling experienced by the vehicle so that the aerodynamics of the flaps will be more quickly effective upon atmospheric reentry	\$58
ADACS and Orbits	Flaps and hinges	This includes the hinges that connect the aerodynamic flaps to the back end of the main CubeSat chassis and the hinge rod that allows the flaps to rotate into their final position. It also includes the flaps themselves, designed out of inconel coated with Teflon that will allow the flaps to maintain rigidity during atmospheric reentry. It also includes the cost of physically manufacturing the components.	~\$12,000
Communications	Antenna	The antenna is the component that converts radio waves to electrical signals and vice versa to allow the transceiver to physically broadcast data from the CubeSat to the Iridium constellation as well as receive data from the constellation when sent from the ground station	\$6
Communications	Radio transceiver	The radio transceiver will both send and receive radio signals that interact with the Iridium satellite constellation, allowing for all data communication between the CubeSat and the ground station	\$1,500
Communications	Iridium Subscription	The agreement that we will have with the Iridium satellite constellation that will allow us to send data between a ground station, the Iridium satellites, and the HARDE CubeSat	\$0
N/A	Miscellaneous	This includes an estimated amount of funding that will be needed for unforeseen components and designs, as well as to cover any parts of the budget that go over their expected costs or need to be replaced	\$10,000
N/A	Wiring	This includes all power and data transfer wiring that is found in the CubeSat	\$1,000
<b>Total</b>		<b>The aggregate cost of all components above</b>	<b>\$63,829</b>

## References

- Anderson, N. (2021). Design of the Sensor Pod of the Hypersonic Configurable Unit Ballistic Experiment (HyCUBE). Retrieved from the University of Minnesota Digital Conservancy, <https://hdl.handle.net/11299/224525>.
- Battery University (2021). What does elevated self-discharge do. Retrieved from BU.com <https://batteryuniversity.com/article/bu-802b-what-does-elevated-self-discharge-do#:~:text=Lead%2D%20and%20lithium%2Dbased%20systems,have%20a%20lower%20self%2Ddischarge.&text=Li%2Dion%20self%2Ddischarges%20about,another%203%20percent%20per%20month>
- Devenport, W. (2022). Compressible Aerodynamics Calculator. Retrieved April 18, 2022, from <http://www.dept.aoe.vt.edu/~devenpor/aoe3114/calc.html>
- Riot, Vincent J., Simms, Lance M., & Carter, Darrell. *Lessons Learned Using Iridium to Communicate with a CubeSat in Low Earth Orbit*. United States.
- Gerhardt, D., Palo, S. (2010). Passive magnetic attitude control for CubeSat spacecraft. SCS10. [https://lasp.colorado.edu/home/csswe/files/2012/06/Gerhardt\\_SSC10\\_PMAC.pdf](https://lasp.colorado.edu/home/csswe/files/2012/06/Gerhardt_SSC10_PMAC.pdf)
- Goggin, M. C., Tamrazian, S., Carlson, R., Tidwell, A., & Parkos, D. (2017). CubeSat Sensor Platform for Reentry Aerothermodynamics. *DigitalCommons@USU*. Retrieved April 18, 2022, from <https://digitalcommons.usu.edu/cgi/viewcontent.cgi?article=3663&context=smallsat>.
- Kumar, R. R., Mazanek, D. D., Heck, M. L. (1995). Simulation and shuttle hitchhiker validation of passive satellite aerostabilization. *J. Spacecraft and Rockets*, 32 (5), 806– 811.
- Kumar, R. R., Mazanek, D. D., Heck, M. L. (1996). Parametric and classical resonance in passive satellite aerostabilization. *J. Spacecraft and Rockets*, 33(2), 228–234.
- Marlin Steel. (2020). 5 Uses for Inconel and why to use it. Retrieved April 18, 2022, from <https://www.marlinwire.com/blog/inconel-use-case-examples#:~:text=Though%20exact%20measurements%20vary%2C%20reported,C%20and%201%2C350%2B0C>).
- NanoAvionics. (2022). Magnetorquers MTQ3X; NanoAvionics: Columbia, IL, Apr. 8, 2019 [Revised Nov. 12, 2019; Mar. 3, 2020; Feb. 14, 2022]. [https://satsearch.s3.eu-central-1.amazonaws.com/datasheets/satsearch\\_ddatasheet\\_klwzvw\\_nanoavionics\\_magnetorquers\\_mtg3x.pdf?X-Amz-Algorithm=AWS4-HMAC-SHA256&X-Amz-Credential=AKIAJLB7IRZ54RAMS36Q%2F20220418%2F%2Faws4\\_request&X-Amz-Date=20220418T183120Z&X-Amz-Expires=86400&X-Amz-Signature=c852d5c39f1cc5b70c36cb4afe6ce0e2eebbe1412e1df3552b6b374139bcef04&X-Amz-SignedHeaders=host](https://satsearch.s3.eu-central-1.amazonaws.com/datasheets/satsearch_ddatasheet_klwzvw_nanoavionics_magnetorquers_mtg3x.pdf?X-Amz-Algorithm=AWS4-HMAC-SHA256&X-Amz-Credential=AKIAJLB7IRZ54RAMS36Q%2F20220418%2F%2Faws4_request&X-Amz-Date=20220418T183120Z&X-Amz-Expires=86400&X-Amz-Signature=c852d5c39f1cc5b70c36cb4afe6ce0e2eebbe1412e1df3552b6b374139bcef04&X-Amz-SignedHeaders=host) (accessed Apr. 18, 2022).

Pacini, L. & Skillman, D. (1995). A passive aerodynamically stabilized satellite for low Earth orbit. AAS/AIAA Spaceflight Mechanics Mtg., Albuquerque, NM.

Rawashdeh, S A. (2019). Attitude analysis of small satellites using model-based simulation. International Journal of Engineering. 2019, 1-11  
<https://doi.org/10.1155/2019/3020581>

Rawashdeh, S. A. and Lumpp, J. E. (2010). Nano-satellite passive attitude stabilization systems design by orbital environment modeling and simulation, in Proc. AIAA Infotech@Aerospace Conf., Atlanta, GA.

Rawashdeh, S. A. & Lumpp, J E. (2013). Aerodynamic stability for CubeSats at ISS orbit. Journal of Open-Source Software, 2(1), 85-104.

## Appendices

### Appendix I: Center of Mass Calculations

$$(M_{\text{battery}} + M_{\text{mcu}} + M_{\text{trans}} + M_{\text{mag}} + M_{\text{antenna}} + M_{\text{frame}} + M_{\text{shield}} + M_{\text{hinge}} + M_{\text{wings}} + M_{\text{lead}}) X_{\text{c.o.m.}}$$

$$= \sum X_i M_i$$

$$\hookrightarrow X_{\text{c.o.m.}} = 17.76 \text{ cm (wings at } 20^\circ)$$

Object	X (cm)	m (kg)
battery	9.08	0.268
mcu	11.78	0.094
trans	14.78	0.032
antenna	30	0.0056
frame	16.50	1.656
shield	2.86	0.268
hinge	29	0.587
wings	38.2	0.192 x4
sensors	2.5	0.061
hyst	13.75	0.15
weight	6	1

## Appendix II: Center of Pressure Calculations

② Mach 20

$q_{\infty} = 91,300 \text{ N/m}^2$   
 $C_L = 0.819$   
 $C_D = 0.055$   
 $L = 8775.055 \text{ N}$   
 $D = 177.265 \text{ N}$   
 $F_{\text{total}} = 8952.32 \text{ N}$   
 $x_{CP} = 16.19 \text{ cm}$

$(81.3)(91,300)(1) = (81.3)(18)(9)(9) = 52,682.4 \rightarrow \text{force total } P$   
 $(16.5)(91,300)(1) = 1,506,450 \rightarrow \text{force to front } P$   
 $(P_{\text{front}})(x_{\text{front}}) = (52,682.4)(16.61) = 8775.055$   
 $(P_{\text{front}})(x_{\text{front}}) = (1,506,450)(21.85) = 1,019,302.5$   
 $x_{CP} = 30.4$

$177.265$   
 $20.695$

### Appendix III: Early Simulation Data

The following images are early examples of SolidWorks fluid simulation. The data is all taken from the same hypersonic simulation with Mach 5 flow at 8 km of altitude. Final calculations will take data at multiple altitudes to determine roughly what the conditions will be at as the spacecraft follows its trajectory.

