

HUMAN-POWERED, ILLUMINATED RUNNER'S VEST

Presented to
The Faculty of the
School of Engineering and Applied Science
University of Virginia
In Partial Fulfillment of the Requirements for the Degree
Bachelor of Science in Mechanical Engineering

By
Trevor Cook

April 28, 2020

Technical Project Team Members
Katarina Catallo
Jacob Fishman
Garrett Hanrahan
Kyle Peter
Clayton Tondreau

On my honor as a University student, I have neither given nor received unauthorized aid on this assignment as defined by the Honor Guidelines for Thesis-Related Assignments.

ADVISOR
Mike Momot, Department of Mechanical Engineering

Table of Contents

1. Introduction
 - a. Executive Summary
 - b. Design Overview
2. Existing Technology
 - a. Market Research
 - b. Competitors
3. Design and Analysis
 - a. Codes and Standards
 - b. Bill of Materials
 - c. Final Parts
 - i. Vest
 - ii. Linear Generator
 - iii. Circuitry
 - iv. Linear Generator Casing
 - v. Bolts, Washers, and Nuts
 - vi. Spring
 - vii. LED Strip
 - viii. LED Strip Casing
4. Calculations
 - a. Optimizing the Electricity Generated by the Magnet
 - b. Spring Constant
 - c. Tolerances
5. Financial Analysis
6. Product Testing
 - a. Aesthetics/Ergonomics Test
 - b. Drop Test
 - c. Interference Test
 - d. Running Frequency Test
 - e. Linear Generator Power Output Test
7. Results and Discussion
 - a. Design for Automation
 - b. Design for Safety
 - c. Design for Environment
 - d. Impact on Environment
8. Design for Manufacture
 - a. Adaptations for Mass Production
 - b. Designing a Linear Generator
 - c. Updated Cost Analysis
9. Ending Remark
10. References
11. Appendix A: Tolerances
12. Appendix B: Drawings

This paper was written as a group, including all team members listed on the cover page.

Introduction

Executive Summary

Our team developed a self-powered, light-up safety vest to provide a means of increasing pedestrian safety. The safety vest includes LEDs that harness energy from the movement of the user when he or she is running. As a user is running, linear generators charge and transmit electricity to the LED strips attached to the running vest. Our product is a self-sustaining power system that provides a high-visibility solution for low-visibility environments.

Design Overview

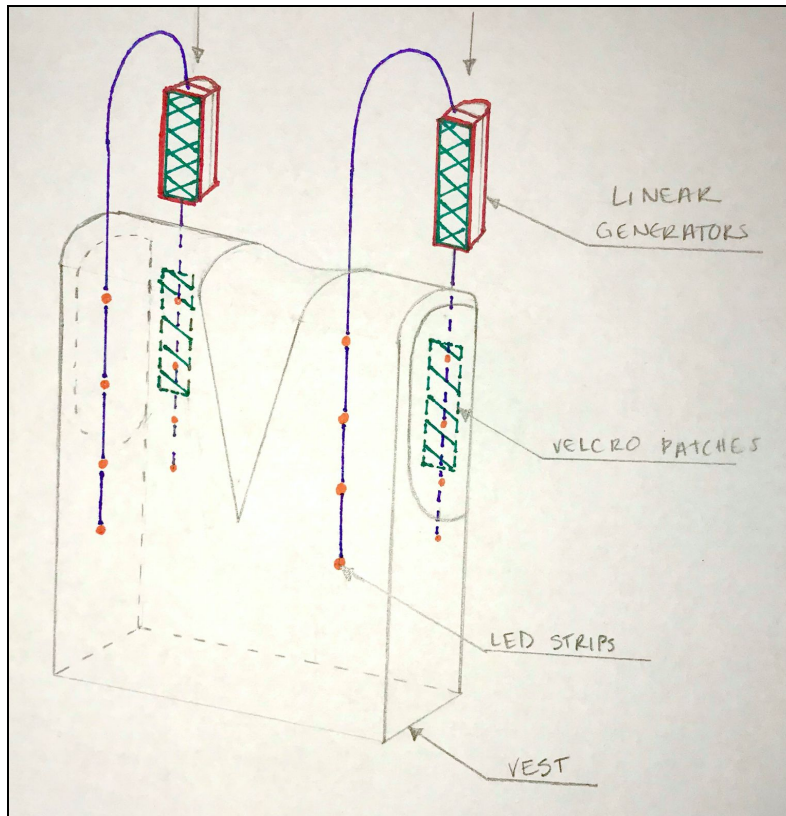

| Color | Part |
|--------|----------------------|
| Grey | Vest |
| Red | Linear Generators |
| Green | Velcro Patches |
| Orange | LEDs |
| Blue | Wires in Wire Casing |

Table 1: Legend for final assembly drawing in Figure 1.

Figure 1: Final assembly drawing including all main parts.

The design of our vest is shown above in Figure 1 in a partially exploded view. Using the

legend colors from Table 1, our design includes one (1) running vest shown in gray, two (2) linear generators shown in red, four (4) velcro patches shown in green, 16 LEDs shown in orange, and four (4) wires housed in wire casings shown in blue. Our linear generators are housed in 3D printed casings designed by our team and are connected to the vest using velcro patches. The velcro patches make the linear generators (and connected LED strips) detachable, allowing the user to wash the running vest without damaging any electrical components.

Existing Technology

Market Research

We conducted market research to affirm our concept design and to shed light on our design priorities. We distributed a survey to 50 runners from the University of Virginia Running Club. The survey indicated that weight and comfort are the most important factors for potential users, as 98% of responders said they would prefer a running vest that is lightweight and comfortable. Our research also confirmed our central design criteria: mechanical charging. 60% of respondents would not want an illuminated vest that requires batteries and 82% of respondents would not want an illuminated vest that needs to be recharged after every use. This research demonstrated the need for a vest that does not have to be charged or require batteries.

Competitors

The main competitor that we found through our research was the Noxgear Tracer360 shown below in Figure 2. This “vest” is a light-up strip of lights that wraps around your body and sells on Amazon for \$60.00. The manufacturer’s website states that its product has a 40-hour battery life (“Noxgear Tracer360 - Performance Safety Visibility Vest,” n.d.). We consider the

Tracer360 our main competitor because it is also a light-up running vest. The primary advantage that our product has over the Tracer360 is our ability to mechanically recharge our lights. A secondary advantage that our product will eventually have is, once we can modify our design for manufacture, our product will be sold for a significantly lower price.

| Size | Chest | Typically fits t-shirt size | |
|------|-----------|-----------------------------|----------|
| | | Men's | Women's |
| S | 25" - 36" | XS, S | XS, S, M |
| M/L | 27" - 40" | M, L | L |
| XL | 29" - 44" | XL | XL, XXL |

Measure and wear under chest for best fit.

Figure 2: Noxgear Tracer360 specifications. (“Noxgear Tracer360 - Performance Safety Visibility Vest,” n.d.)

Design and Analysis

Codes and Standards

| Code or Standard | Part | Source |
|---|----------------------------|---|
| Alloy Wire International | Coil, Wire for LED | https://www.alloywire.us.com/tolerances/ |
| American National Standard Running and Sliding Fits ANSI B4.1-1967 (R2004) chart | Magnet, Barrel, and Casing | ANSI |
| American National Standard Loose Running Fit (C11, h11 or Class RC 9) | Magnet, Barrel, and Casing | ANSI |
| Standard Spring Dimension Tolerances | Spring | https://www.acesspring.com/standard-spring-tolerances-for-custom-and-stock-springs.html |

Table 2: Codes and standards used for parts and tolerances.

Bill of Materials

| Group | Quantity | Description | Material |
|------------------|----------|---|-------------------------------|
| LED | 16 | LED | Ti-3/4 (5 mm) TLCY6800 |
| LED | 16 | LED Casings | ABS Plastic |
| LED | 16 | Breadboard | Plastic |
| LED | 43" | Wire | PVC insulated 24 Gauge Copper |
| LED | 43" | Heat-Shrink Tubing | Thermoplastic |
| Vest | 1 | Vest | Nylon |
| Vest | 4 | Velcro Strips | Velcro |
| Linear Generator | 2 | Casing | ABS Plastic |
| Linear Generator | 2 | Springs | Music wire |
| Linear Generator | 2 | Magnet | Neodymium |
| Linear Generator | 2 | Circuitry | PCB & Copper Wire |
| Linear Generator | 2 | Barrels | PVC |
| Linear Generator | 2 | Barrel Caps | PVC |
| Linear Generator | 4 | 1/4 in.-20 x 2-1/2 in. Zinc Plated Hex Bolt | Zinc-Plated Steel |
| Linear Generator | 4 | 1/4 in. Zinc-Plated Split Lock Washer | Zinc-Plated Steel |
| Linear Generator | 4 | 1/4 in.-20 Zinc Plated Wing Nut (4 pack) | Zinc-Plated Steel |

Table 3: Bill of materials for the finished product.

Final Parts

Vest

We chose to outsource the vest part of our design because of the prevalence of reflective running vests on the market. After researching multiple options, we decided to purchase the GoxRunx Running Vest (shown below in Figure 3) which is a high-visibility, neon vest designed for runners (“Breathable Mesh Cycling Outdoor Sports Night Running Vest,” n.d.). Individuals who run at night already use 3M reflective gear, so we used that existing technology in our vest choice and design. This vest was selected as it is tighter around the body than other vests, which dampened unnecessary motion that occurred in the linear generator. The unnecessary motion decreased efficiency in the linear generator, so eliminating the motion maximized the efficiency of the generator.



Figure 3: Screenshots from Amazon of the GoxRunx running vest purchased.

Linear Generator

We decided to use a linear generator because it was the easiest and most efficient way to generate electricity while walking or running. We knew whatever device we came up with would have to be attached to the torso of the body to minimize discomfort for the user. It would have been much more difficult to attach any type of generator to the arm or leg. The upper chest and back, however, experiences much less rotational movement and is supported by more of the body's bone structure as opposed to the muscles required when adding weight to the arm or leg.

While walking and running, there is a small amount of vertical oscillation of the torso. We harnessed that energy by attaching the linear generator vertically on the vest. The linear generator works by allowing a permanent magnet to pass through coils of wire. According to Faraday's Law, as the magnetic flux changes around a wire, an electromotive force is induced. In our linear generator shown in Figure 4 below, the cylindrical magnet is a fraction of the length of the barrel that it resides in. The wire is wrapped around the barrel and both are attached securely to the vest, making them stationary with respect to the user's body. The magnet, however, is free to move within the barrel. As the user's body moves upwards when running and back down due to gravity, the magnet also oscillates at the same frequency as the runner's cadence. Therefore, the magnet passes both upwards and downwards through the coil during each period, inducing an EMF in the coil each time. Technical drawings of the magnet, barrel caps, barrel, and an assembly of the entire linear generator can be found in Appendix B.

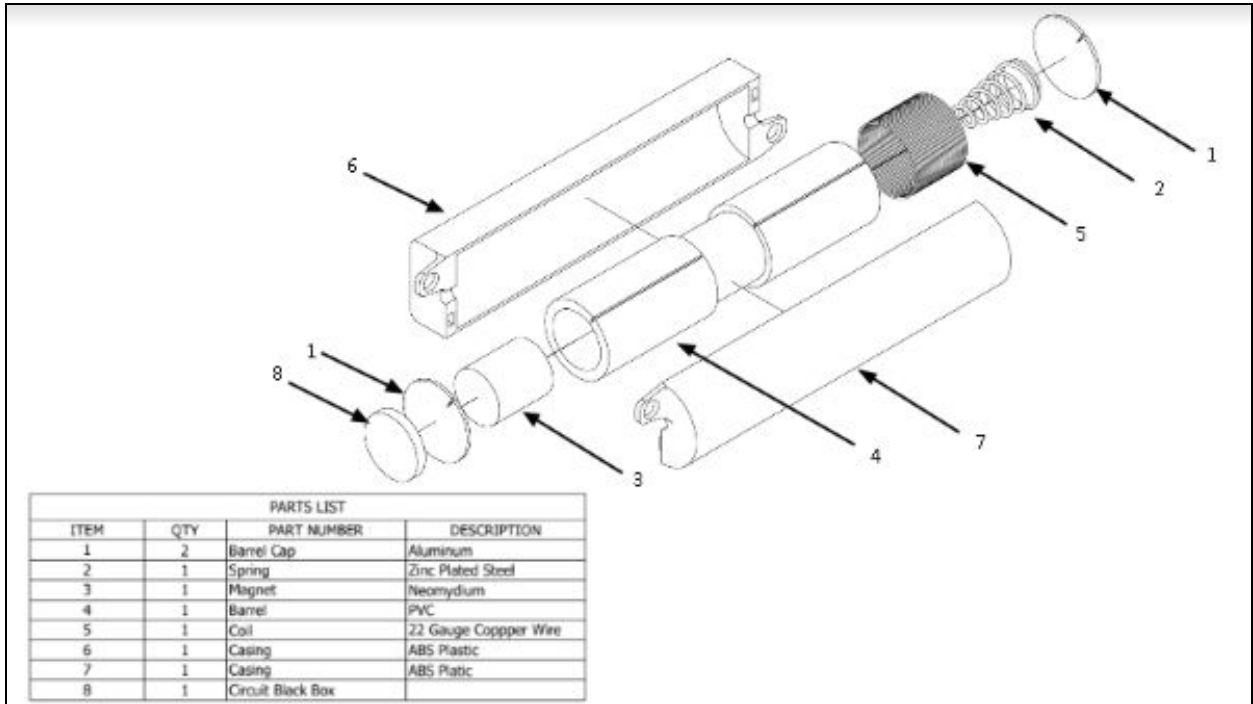

Figure 4: Exploded view of the linear generator with all components.

Circuitry

As shown below in Figure 5, the circuitry for our device was very simple as it only included five components including the LED strip. Both ends of the coil of wire wrapped around the barrel of the linear generator run into the bridge rectifier. This converts the AC current to DC. As the DC current flows through the circuit, it charges up the battery. The circuit contains a switch, ensuring the LED strip does not always stay on. When the switch is closed, the battery is discharged through the LED strip and resistor, in series, which lights up the LED strip.

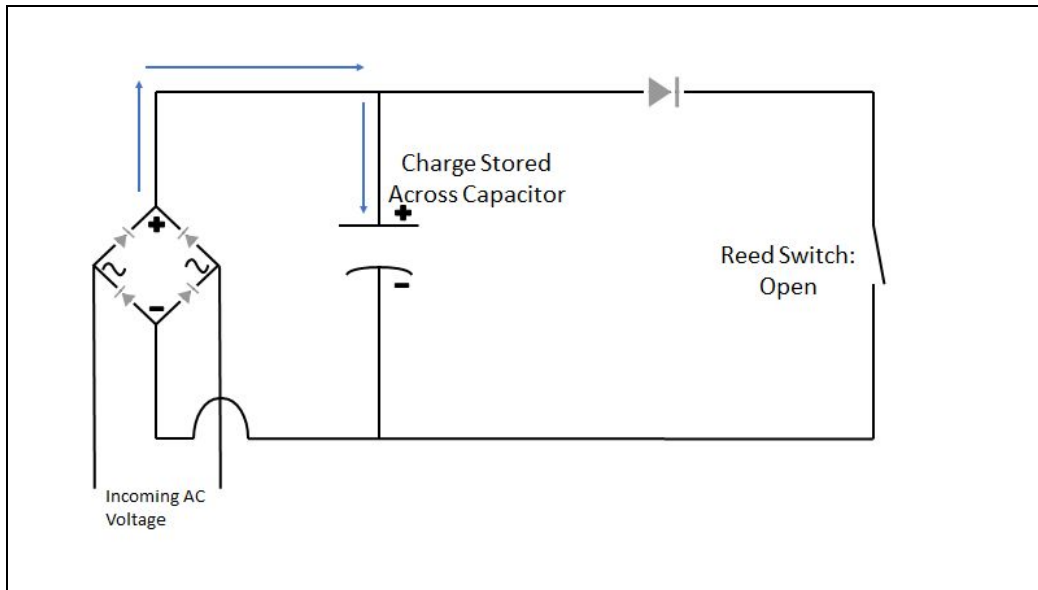

Figure 5: Circuit diagram.

Linear Generator Casing

After three previous iterations, our team finalized the linear generator casing design shown in Figure 6. The casing was printed using FDM 3D printers at the Rapid Prototyping Lab in the UVA Mechanical and Aerospace Engineering Building. It was composed of ABS plastic in an ivory color with a plan to paint over it with another color so it would match the vest aesthetically.

The casing consists of two pieces: the top piece and the bottom piece, shown in images A and B of Figure 6 respectively. The top piece has a semicircular cross-section and is what faces outwards from the vest. The bottom piece has a rectangular cross-section and the velcro patch was adhered to the flat side of it to enable the whole casing to attach to the vest. We used guiding extremities (shown in image A) that would insert into the holes (shown in image B) to allow the top piece to sit over the bottom piece securely. We also designed two circular holes on opposite corners of the pieces for the use of bolts, washers, and nuts to fasten the top and bottom pieces

together. This connection is shown in images C and D, which depict the closed casing assembly and its exploded view respectively.

Dimensioned, toleranced drawings of what is discussed above are shown in Appendix B. All drawings were developed in Autodesk Inventor 2019. All tolerances for FDM printing are +/- 0.5%, unless otherwise specified (“Dimensional Accuracy of 3D Printed Parts,” n.d.).



Figure 6: Screenshots of the final linear generator casing design developed on Autodesk Inventor 2019.

Bolts, Washers and Nuts

In order to fasten the casing to ensure the linear generator does not fall out, we used bolts, washers and nuts. There were two (2) bolts shown in Figure 7, two (2) washers shown in Figure

8, and two (2) nuts shown in Figure 9 for each linear generator casing. Specifications were as follows: one quarter inch diameter two and a half inches long zinc-plated hexagon bolts, quarter inch diameter zinc-plated split lock washers, and quarter inch diameter zinc-plated wing nuts, respectively.



Figures 7, 8, 9: Image of a zinc-plated hexagon bolt, zinc-plated split lock washer, and zinc-plated wing nut. Sources: Amazon, Home Depot, and Home Depot.
(Bolt) (Washers) (Wing-Nuts)

Spring

The spring was selected based on the criteria described in the Calculations section below, titled Spring Constant. The spring constant was taken into consideration as well as the diameter of the barrel. The resulting spring that was selected, shown below in Figure 10, will be outsourced and the tolerances were calculated in accordance with the standard tolerances for a compression spring.



Figure 10: Image of a compression spring with similar dimensions to what we are using.
Source: Global Industrial

LED Strip

Once electricity is generated by the linear generator, it is conducted to the LEDs through the LED strip. There are four LED strips: two on front of the vest and two on the back. There are a total of 16 LEDs, with eight on the front and eight on the back. As shown in Figures 11 and 12 below, the LEDs are connected to one another using 10-22 gauge copper wire that is sealed using heat shrink wrapping. The positive and negative terminals of the LEDs and wire are soldered together onto a 1x6 in. breadboard. All of these internal connections of the LEDs and the wires are housed by a casing that protects the connections from any interference from consumer use.

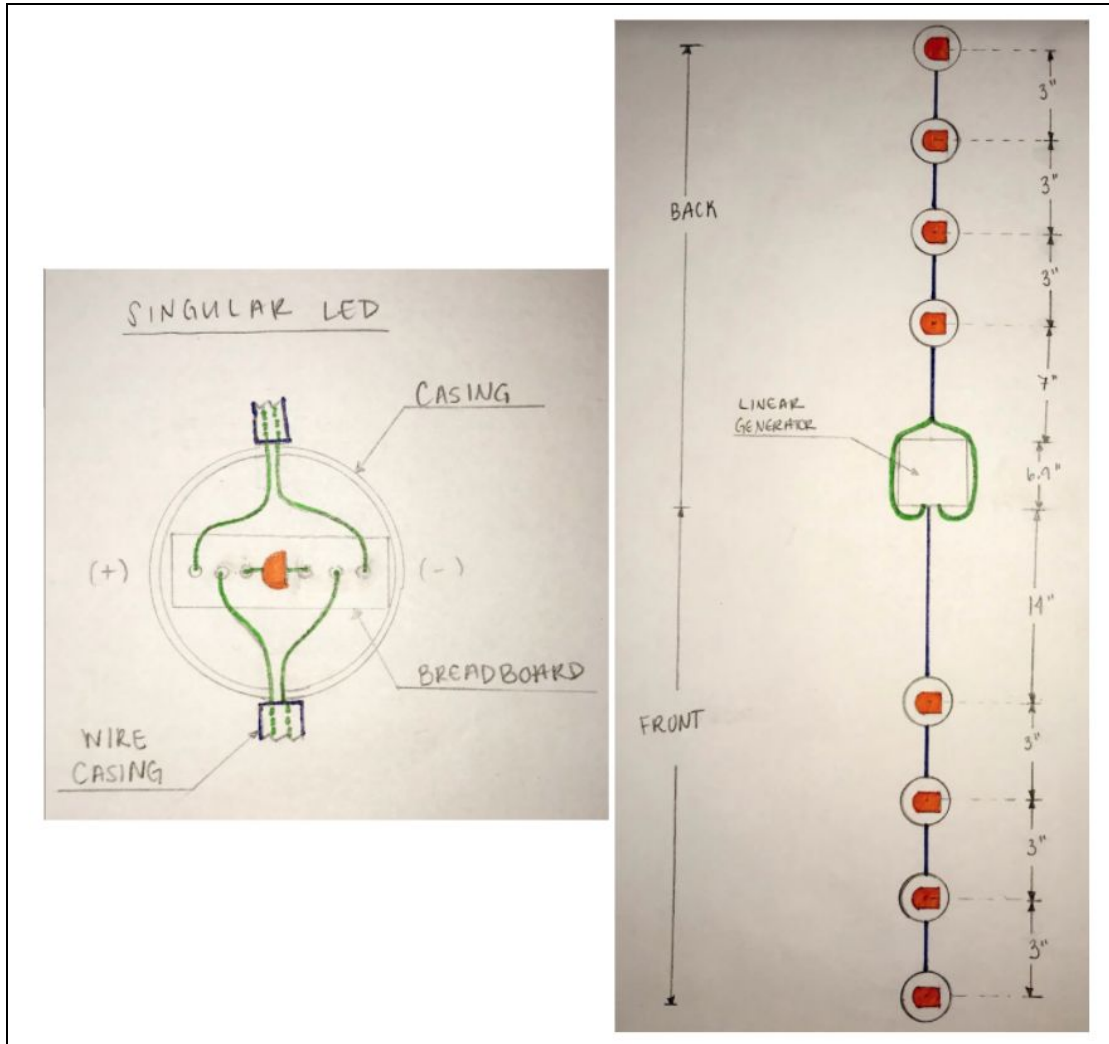

Figure 11: Technical drawing of one LED (left). Assembly drawing of one LED strip (right).

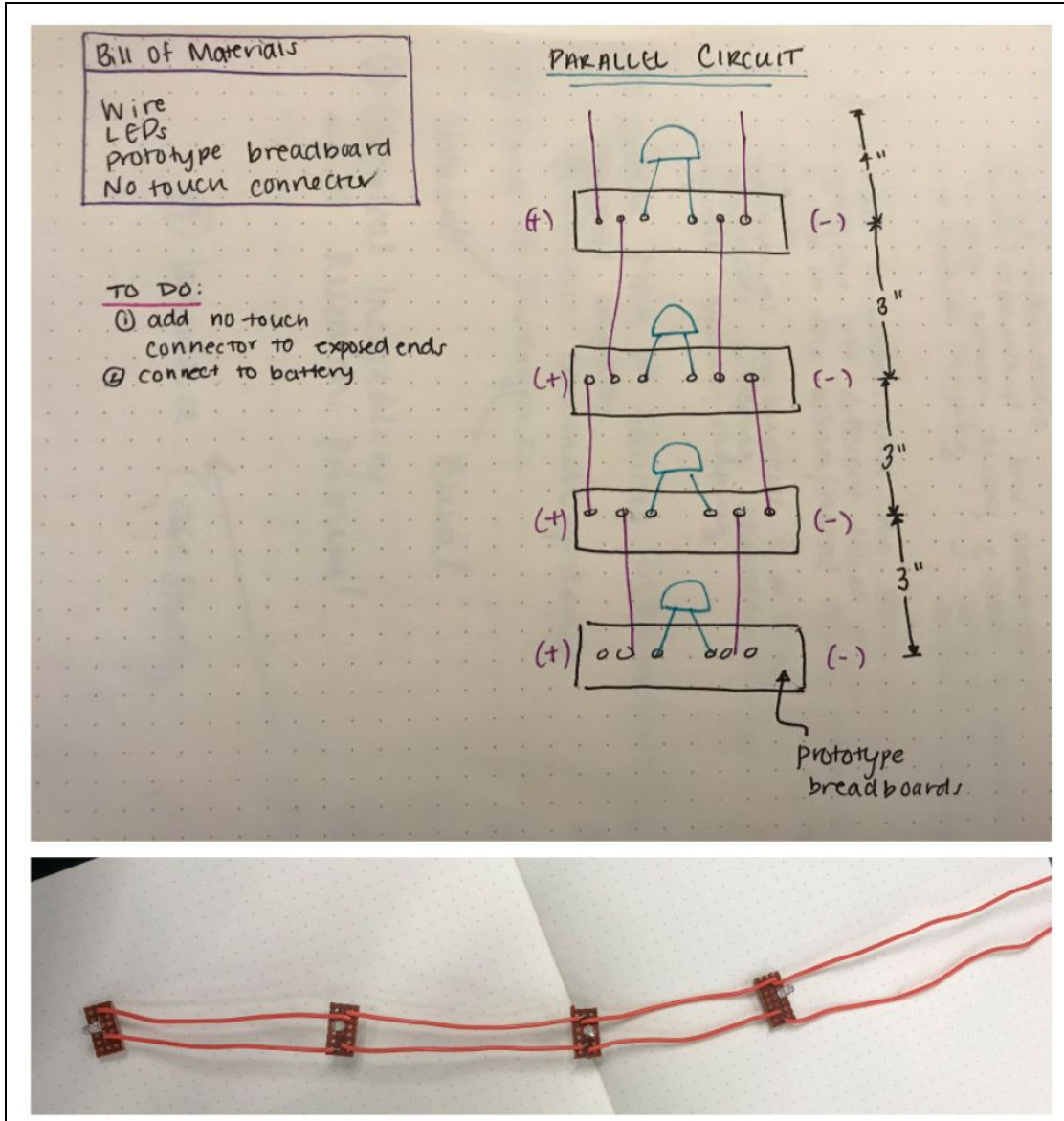

Figure 12: Parallel circuit schematic diagram for the LED Strip (top). Picture of the LED strip we developed (bottom).

LED Strip Casing

The LED Strip Casing was designed to improve aesthetics of the product and to protect electronics from water or other damage. The entire LED 1x6 in. breadboard fits into the casing, which leads the wires out of either side to the next LED breadboard or into the linear generator casing to the circuitry box inside. The assembly of the casing, shown on the left side of Figure

11, is very simple and easy to manufacture. The LED breadboard is placed into the LED Casing Bottom with the wires running through the trenches on either side. The LED Casing Top is then placed onto the shelf of the LED Casing Bottom, exposing the LED and its generated light through the hole in the center. The LED Casing Top is then twisted clockwise (when viewing LED Casing Bottom from the top) to lock it in place. Technical drawings of the LED Casing Top and Bottom can be found in Appendix B.

Calculations

Optimizing the Electricity Generation of the Linear Generator

1. Spring testing
 - a. Multiple springs were bought and tested, shown in Figure 13 below. Springs were adjusted in order to maximize magnet movement. Most springs were still too stiff.
 - b. We then chose to evaluate the gold spring and the use of a rubber band, also shown in Figure 13.

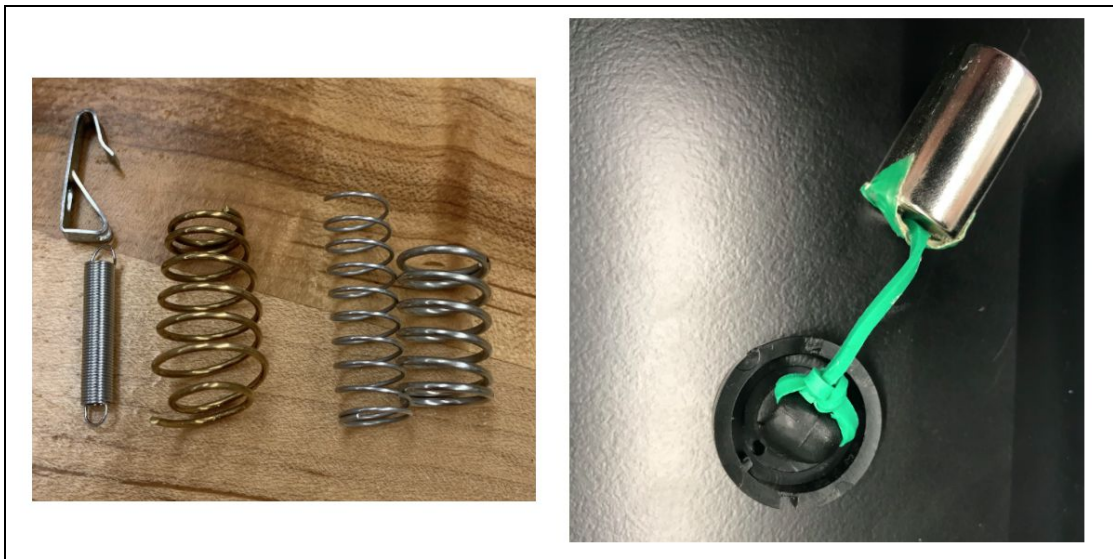

Figure 13: Purchased springs for initial spring testing (left) and rubber band setup connecting the bottom barrel cap to the magnet (right).

2. Spring Decision Matrix

a. Final Decision: compression spring

| Selection Criteria | Tension Spring | | | Compression Spring | | | Rubber band | | |
|--|----------------|---|---|--------------------|---|---|-------------|---|---|
| Ease of manufacture | + | + | + | + | + | + | - | + | + |
| Ability to reproduce easily | + | + | + | + | + | + | - | - | + |
| Number of parts | + | + | + | + | + | + | - | + | + |
| Lifespan/durability (max number of cycles) | + | + | 0 | + | + | + | - | - | - |
| Appropriate stiffness | - | - | - | - | - | - | + | + | + |
| Adaptability | - | 0 | + | - | - | + | + | - | - |
| Cost | 0 | + | + | 0 | + | + | + | + | + |
| Sum +'s | 14 | | | 15 | | | 12 | | |
| Sum 0' | 3 | | | 1 | | | 0 | | |
| Sum -'s | 4 | | | 5 | | | 9 | | |
| Net Score | +10 | | | +10 | | | +3 | | |
| Rank | 2 | | | 1 | | | 3 | | |

Table 4 : Spring Decision Matrix. This was used to decide between different types of springs to assist the motion of the magnet through the barrel. Because of the results, a compression spring was chosen.

Spring Constant

The spring constant is a measure of the force required per unit extension and its units are N/m or lbf/in (“Spring Constant Formula | Spring Constant Formulas Using Hooke’s Law,” n.d.). The standard formula for spring constant (k) is $F = -kx$. When calculating potential properties for

our spring, we used the simple harmonic motion formula for a spring. The simple harmonic motion formula is as follows,

$$\omega = \sqrt{\frac{k}{m}}$$

where ω is frequency (of the runner or jogger), k is spring constant, and m is mass of the motion. As discussed below in the Product Testing section, we found that the natural frequency of a runner is approximately 2 steps per second. Using this equation, the measured frequency and our mass which we measured at 38.321 grams, we found the ideal spring constant to be 0.153 N/m. Since our design was done in United States customary units, we converted to lbf/in, resulting in a value of 1.357 lbf/in. Using this spring constant and our measurements of the casing, we found one spring to be most ideal for aiding our linear generator in motion. Specific information on the chosen spring is shown below in Table 5 (“Compression Spring PC014-180-10900-MW-1014-C-N-IN - The Spring Store,” n.d.).













| Compression Spring Dimensions - IN | | |
|---|-------------------------------|--------------------------------|
|  | Stock Part Number | PC014-180-10900-MW-1014-C-N-IN |
|  | Outer Diameter | 0.180 |
|  | Inner Diameter | 0.152 |
|  | Free Length | 1.014 |
|  | Solid Height | 0.167 |
|  | Wire Diameter | 0.014 |
|  | Total Coils | 10.900 |
|  | Rate (lbs./in.) | 1.356 |
|  | Max. Load | 1.004 |
|  | Max. Deflection (Max. Travel) | 0.741 |
|  | Material Type | MW - Music Wire |
|  | End Type | C |

Table 5: Dimensions for the chosen compression spring dimensions.

Tolerances

Tolerances for the magnet, barrel, and casing diameters were based on ANSI running and sliding fits (ANSI Table B4.1). Loose running fits (C11/h11, Class RC 9) were chosen because they have the largest clearance, making it cheaper for commercial manufacture. (“American National Standard Running and Sliding Fits,” n.d.) For the barrel length, we used a ± 0.05 in tolerance. For the casing length, we used a ± 0.1 in tolerance. These two tolerances were chosen to minimize cost while still ensuring a high level of precision with printing. Clearance calculations are shown below between the magnet and barrel in Figure 14, and between the barrel and casing in Figure 15. A table of all tolerances used can be found in Appendix A.

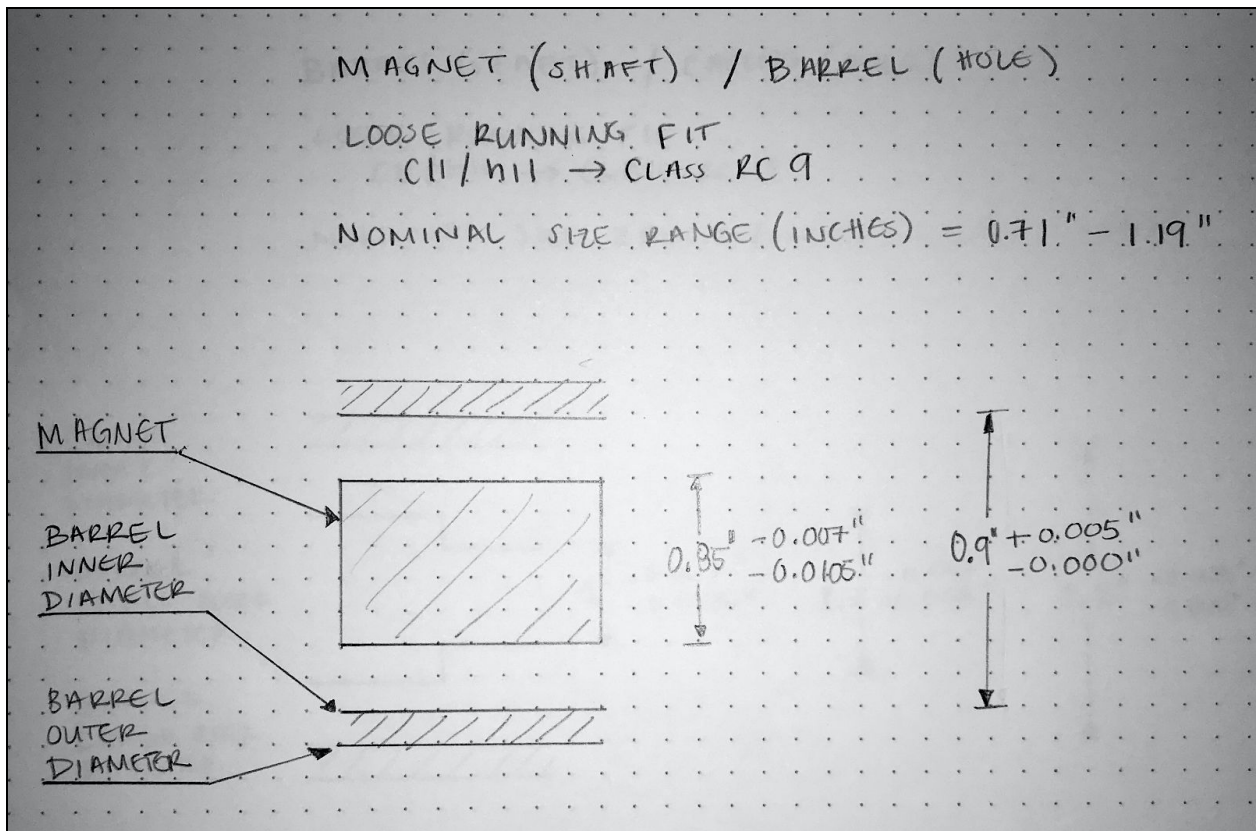

Figure 14: Clearance calculations for the tolerances of the magnet and barrel diameters.

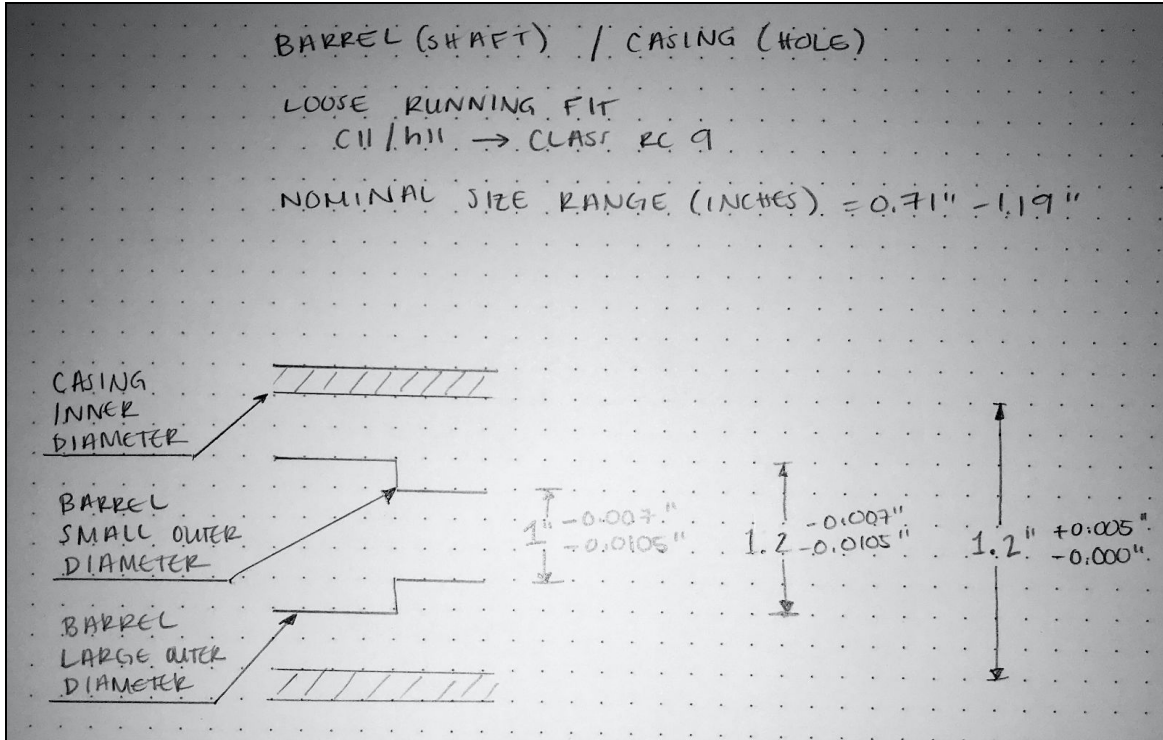

Figure 15: Clearance calculations for the tolerances of the barrel and casing diameters.

For all parts that were 3D printed, tolerances were calculated as $\pm 0.5\%$ of the measurement, as set by the printer manufacturer (“Dimensional Accuracy of 3D Printed Parts,” n.d.). These dimensions include the length of the barrel, the length of the barrel cap, the length of the casing, and all dimensions of the LED strip casing.

Tolerances for the standard compression spring chosen are shown below in Table 6 (“Standard Spring Dimension Tolerances for Custom and Stock Springs - Quality Spring, Affordable Prices,” n.d.).

| | Parameter | Measurement (inches) | Tolerance (inches) |
|---------------|----------------------|----------------------|--------------------|
| Spring | Wire Diameter | 0.014 | ± 0.0005 |
| | Free Length | 1.014 | ± 0.050 |
| | Small Outer Diameter | 0.152 | ± 0.005 |
| | Large Outer Diameter | 0.18 | ± 0.005 |
| | Solid Height | 0.167 | ± 0.012 |

Table 6: Compression spring dimensions and tolerances.

Financial Analysis

Based on items purchased or made from various sources shown below in Table 7, the total project cost for one unit of our final product was 55.05 USD. Most items were considered “Raw Materials” as individual parts were purchased and assembled by our team. Two items were considered “OEM,” or original equipment manufacturer, because they were assembled by other manufacturers. The last item, the “Linear Generator Casing,” was produced in the Rapid Prototyping Lab at the UVA Mechanical and Aerospace Engineering building.

| Item | Group | Classification | Unit Price | Quantity | Total Price |
|---|------------------|----------------|------------|----------|----------------|
| Copper Wire, insulated, #24, 15' | Wire | Raw Materials | \$2.35 | 0.13 | \$0.31 |
| LED Lights, Vishay TLCY6800 | Wire | Raw Materials | \$0.15 | 16 | \$2.40 |
| Shake Flashlight | Linear Generator | OEM | \$7.99 | 2 | \$15.98 |
| Running Vest (2 pack) | Vest | OEM | \$18.00 | 0.5 | \$9.00 |
| Compression Springs (12 pack) | Linear Generator | Raw Materials | \$5.50 | 0.17 | \$0.94 |
| Velcro strips, 75 ft | Vest | Raw Materials | \$18.61 | 0.053 | \$0.99 |
| Spray Adhesive | Vest | Raw Materials | \$12.19 | 0.1 | \$1.22 |
| Linear Generator Casing | Casing | Produced | \$10.64 | 2 | \$21.28 |
| 1/4 in.-20 x 2-1/2 in. Zinc Plated Hex Bolt | Casing | Raw Materials | \$0.25 | 4 | \$1.00 |
| 1/4 in. Zinc-Plated Split Lock Washer | Casing | Raw Materials | \$0.19 | 4 | \$0.76 |
| 1/4 in.-20 Zinc Plated Wing Nut (4 pack) | Casing | Raw Materials | \$1.18 | 1 | \$1.18 |
| Total Project Cost | | | | | \$55.05 |

Table 7: Cost breakdown for each material purchased and used toward our final product.

All costs in this financial analysis were considered fixed costs because the parts were bought individually for a single product. If we were to continue this project in the future and design for manufacture, described in a later section, we can use economies of scale to our advantage and drive the price of individual items down due to bulk purchases. Three items (shake flashlight, running vest, and linear generator casing) accounted for roughly 85% of our total project cost. Thus, they were our main focuses when evaluating design for manufacture.

Product Testing

Aesthetics/Ergonomic Tests

Aesthetics and ergonomic tests were performed from February 18th-20th by leaving our product with three other professors within the Mechanical and Aerospace Engineering department at UVA for three days and asking for their feedback. At the time, we did not have a final, assembled product, so we delivered the following separate parts together: one linear generator casing, one linear generator connected to one LED strip, and one running vest.

The feedback gathered was very positive. The professors tested the linear generator and reported that the lights worked as expected. They also liked the design of the linear generator casing, specifically the rounded side that faces outward on the vest. Their one note with the casing was a suggestion to mimic that rounded edge on the other side of it as well so that it is more ergonomic when held in the hand. However, we decided to keep our design because one side needs to be flat so that the casing can be attached to the vest via velcro and not held in one's hand. At the time, this was a miscommunication on our part as professors were not aware that the casing was to be fixed to the vest and not held in the user's hand.

Drop Test

The drop test for our product was performed on February 25th. The linear generator was protected by the first version of the casing. This version of the casing did not work perfectly because the snap fits did not 3D print correctly. To continue with the test, we sealed the casing with the linear generator inside of it using electrical tape. It was then dropped from approximately 30 inches, or the height of a table. The drop test was deemed successful because the casing did not break, and it protected the linear generator. This test should be performed with

our updated version of the casing. In addition, to increase the reliability and accuracy of this test, it should be performed multiple times from a height of 50 inches. This height is equal to the average shoulder height of a human, and therefore would be more representative of a situation when the product falls and hits the ground.

Interference Test

After creating an assembly in Autodesk Inventor 2019 of our linear generator (with all its components) inside our linear generator casing, we performed an interference test on the whole assembly. The software reported zero interferences present.

Running Frequency Test

The running frequency test was performed on January 30th. Two group members served as the subjects for the test. We measured a distance of 20 ft on the ground and used tape as markers for the distance. Each subject started 10-15 ft before the first tape marker, and jogged past the two tape markers. The other individual stood between the two tape markers and timed how long it took for the runner to cover the 20 ft. Ten trials were performed per subject, with a total of 20 total data points. After analyzing the data, we concluded that the average frequency, or cadence of a runner is 2 steps/second. This value was used when finding a spring for the linear generator so that our magnet's movement would match the frequency of the average runner.

Linear Generator Power Output Test

After deciding to use two linear generators on our vest instead of four, we needed to ensure that one linear generator could feasibly power two LED strips (one for the front of the vest and one for the back). To test this, we connected two LED strips, with four LED lights on each, to one linear generator electrical circuit after shaking the light for about 30 seconds. The

LED lights functioned properly and there was no drop-off in the brightness of the lights when compared to using just one LED strip. This meant that we were able to change our design from having four linear generators to two, substantially simplifying our design, lowering our cost, and improving both comfort and simplicity for the user.

Results and Discussion

Design for Automation

1. The casing was designed for 3-D printing possibilities, but it was also designed so it could later be cast into a mold for automated injection molding.
2. Screws were used to secure the two halves of the casing together around the internal components.
3. Components were designed to be placed in two principal directions: one along the axis of the casing cylinder and one perpendicular to that axis.
4. Components were simply designed and enclosed, so as not to tangle with adjacent parts.

Design for Safety

1. All wires and cables were insulated using heat-shrink tubing to avoid short circuiting.
2. The linear generator casing was designed to house all inner electronics and prevent water infiltration.
3. The LED casing was designed to house all exposed wire endings and protect circuit connections.
4. Velcro provides a secure attachment point between the vest and the linear generator that does not pose any risks to the consumer.

5. There are no small parts outside of the casing that could be a choking hazard.

Design for the Environment

1. Nylon was used because it is the standard material for safety vests. For manufacture, we will switch to an eco-friendly polyester material.
2. Use of recycled aluminum
3. Use of recycled copper.
4. LED bulbs are the most efficient type of lighting apparatus available on the market.

Impact on the Environment

Our design was made to be simplistic and user friendly. The safety vest is an item used in a variety of settings, such as construction or athletics, making it easily attainable. While safety vests are abundant and cheap, they are not very environmentally friendly. They are made of nylon, which is made by processing petroleum into one form of plastic. The manufacture of nylon produces nitrous oxide, which is a greenhouse gas that is 300 times stronger than carbon dioxide. In addition, the manufacture of nylon requires a refining process, which uses a lot of water and energy. With commercial manufacturing of our product in mind, we recommend switching materials to recycled, eco-friendly polyester that could be sewn into a vest. This would decrease our environmental impact by eliminating the nylon used.

The use of aluminum in our design makes our product more sustainable because aluminum can be recycled repeatedly without losing its defining qualities. Aluminum is also extremely abundant.

LED bulbs are more environmentally friendly than incandescent bulbs and compact fluorescent lights. LED bulbs consume less power per unit of light emitted, thus increasing their

efficiency. With a fixed amount of power created by our linear generator, LED bulbs can be lit up longer than incandescent bulbs. In addition, LED bulbs are made using aluminum, further increasing the sustainability of our product.

The use of copper for our wires was chosen because of its natural conductive properties. Most of the environmental impact from copper results from the original extraction of copper, through mining. The mining process is extremely energy-intensive and produces harmful waste products. Some environmental effects of the mining process include land degradation, deforestation, habitat destruction, and groundwater pollution. However, copper can also be recycled, and it is the most recycled material after iron and aluminum. The recycling of copper uses 20% of the energy that would be used to mine and extract the same amount of copper. To minimize the negative environmental impact of copper use in our product, we should use recycled copper materials.

Design for Manufacture

1. Barrel material was chosen with the highest magnetic permeability possible while remaining lightweight.
2. Bolts, nuts and washers are abundant and widely used in manufacturing processes.
3. Casing material (ABS plastic) was chosen for prototyping, but may change for mass production.
4. Injection molding was chosen for mass production to reduce production costs and speed of production.
5. If the linear generators can be bought cheaply, we will use them as OEM parts. However, we can use injection molds instead to lower cost.

6. LED Strip Casing is easily manufactured from injection molds and assembled around the LED Strip.
7. Heat wrap is easy to use and a low cost system.

Adaptations for Mass Production

When considering adaptations for mass production, we mainly focused on the shake flashlight, running vest, and linear generator casing parts as they accounted for around 85% of the total unit cost. The linear generator casing has been changed from 3D printing to Injection Molding. The casing material will remain ABS plastic with a cost of around \$1.29 per vest. The cost of purchasing a custom mold from online estimates is a one-time cost of around \$10,000. If 10,000 vests were produced, the price per vest for the casing would reduce from \$21.28 to \$2.29. In addition, a comparable vest was found for bulk purchase online for \$0.75 when bought in over 1,000 units. This would reduce the price of the vest from \$9.00 to \$0.75.

The LED Casings would also be injection molded from ABS plastic, meaning another one-time cost of around \$10,000 was included in the cost estimate as well as the price of the material per casing. Shrink wrap systems can be purchased for \$180.00 in addition to the price of the roll of the wrap itself. All together this would add about 3 cents per unit to shrink wrap the wires.

Designing a Linear Generator

In order to reduce cost, our proprietary linear generator was designed using the shake flashlight as inspiration. The cost for each part, including the circuit board, has been calculated from online catalogs to be bought in bulk. In the following updated cost analysis, the price of each component is displayed along with the total cost.

The casing for the linear generator was designed to be injection molded with ABS plastic. This casing is a simple design and, based on online estimates, the mold itself would cost between \$5,000-\$10,000 (depending on complexity category). The other option, if cheaper, is to purchase a linear generator as an OEM part.

Updated Cost Analysis

Table 8 below shows the total cost for mass production. The variable cost for injection molding has been calculated at 10,000 vests, with the overall cost of the vest decreasing if more vests were to be produced. Overall, the cost for mass production has been reduced to a total unit cost of \$20.83.

| Item | Group | Classification | Unit Price | Quantity | Total Price |
|---|------------------|----------------|------------|----------|----------------|
| Copper Wire, insulated, #24, 15' | Wire | Raw Materials | \$2.35 | 0.13 | \$0.31 |
| LED Lights, Vishay TLCY6800 | Wire | Raw Materials | \$0.15 | 16 | \$2.40 |
| U-line shrink wrap | Wire | Raw Materials | \$0.03 | 1 | \$0.03 |
| Abs LED covers | Wire | Raw Materials | \$2.00 | 1 | \$2.00 |
| Plastic Casing | Linear Generator | Raw Materials | \$2.29 | 2 | \$4.58 |
| Copper Wire, uninsulated | Linear Generator | Raw Materials | \$0.42 | 2 | \$0.84 |
| Neodymium Magnet | Linear Generator | Raw Materials | \$0.50 | 2 | \$1.00 |
| Bridge Rectifier | Linear Generator | Raw Materials | \$0.18 | 2 | \$0.36 |
| Battery | Linear Generator | Raw Materials | \$1.00 | 2 | \$2.00 |
| Hi Vis Sports Running Vest | Vest | OEM | \$0.75 | 1 | \$0.75 |
| Compression Springs (12 pack) | Linear Generator | Raw Materials | \$5.50 | 0.17 | \$0.94 |
| Velcro strips, 75 ft | Vest | Raw Materials | \$18.61 | 0.053 | \$0.99 |
| Spray Adhesive | Vest | Raw Materials | \$12.19 | 0.1 | \$1.22 |
| Casing Iteration 3 | Casing | Raw Materials | \$1.15 | 2 | \$2.30 |
| 1/4 in.-20 x 2-1/2 in. Zinc Plated Hex Bolt | Casing | Raw Materials | \$0.13 | 4 | \$0.52 |
| 1/4 in. Zinc-Plated Split Lock Washer | Casing | Raw Materials | \$0.05 | 4 | \$0.20 |
| 1/4 in.-20 Zinc Plated Wing Nut (4-Pack) | Casing | Raw Materials | \$0.10 | 4 | \$0.40 |
| Total Project Cost | | | | | \$20.83 |

Table 8: Updated cost analysis after considering design for manufacture.

Assuming the consumer price would be two times the production cost, the consumer price would be about \$42.00. The Noxgear Tracer360, our closest competitor product, is listed on Amazon for \$60.00, so our product would be \$18.00 cheaper and would not require any additional power cost from batteries or charging. This price gap will allow us to further explore

product quality increases such as aluminum casings for the barrels and recycled copper for the wire.

Ending Remark

Midway through the 2020 spring semester, all courses at the University of Virginia were moved online due to the COVID-19 pandemic. All team members in this project either went to their respective hometowns or stayed in Charlottesville in their apartments. Because of this, we were unable to continue and/or finish our physical product or even retrieve our physical work in progress. This paper was written to include all of the work we performed before courses were moved online as well as the work we would have completed had we been able to finish our project in person.

References

3522 Adafruit Industries LLC | Magnetics—Transformer, Inductor Components | DigiKey.

(n.d.). Retrieved April 30, 2020, from

https://www.digikey.com/product-detail/en/adafruit-industries-llc/3522/1528-2336-ND/7393587?utm_adgroup=Magnetic%20Wire&utm_source=google&utm_medium=cpc&utm_campaign=Shopping_Magnetics%20-%20Transformer%2C%20Inductor%20Components_NEW&utm_term=&utm_content=Magnetic%20Wire&gclid=Cj0KCQjws_r0BRCwARIsAMxfDRgaizwhUo2_Mu7XjHv6fack6mIkL64keGgGfaxo-QaNVqYNBIaMleIaAjXyEALw_wcB

American National Standard Running and Sliding Fits. (n.d.). Retrieved April 30, 2020,

from http://www.zpag.net/Usinage/standard_ansiB4_1_1967.htm

Bolt. (n.d.). Retrieved April 30, 2020, from

https://images-na.ssl-images-amazon.com/images/I/71eTg475LWL._SL1500_.jpg

Breathable Mesh Cycling Outdoor Sports Night Running Vest. (n.d.). Retrieved April 30,

2020, from

https://www.alibaba.com/product-detail/Hi-Vis-Breathable-Mesh-Cycling-Outdoor_62019375120.html?spm=a2700.7724857.normalList.13.5db9119fohXxJ0&s=p&fullFirstScreen=true

Compression Spring. (n.d.). Retrieved April 30, 2020, from

https://images.globalindustrial.com/images/1500x1500/GDS_36060GS.jpg

Compression Spring PC014-180-10900-MW-1014-C-N-IN - The Spring Store. (n.d.).

Retrieved April 30, 2020, from

<https://www.thespringstore.com/pc014-180-10900-mw-1014-c-n-in.html>

Cylinder Magnets Neodymium. (n.d.). Retrieved April 30, 2020, from

<https://www.magnet4sale.com/neodymium-magnets/cylinder-magnets/>

Dimensional accuracy of 3D printed parts. (n.d.). 3D Hubs. Retrieved April 30, 2020, from

<https://www.3dhubs.com/knowledge-base/dimensional-accuracy-3d-printed-parts/>

How Much Does Injection Molding Cost? | Rex Plastics Mold Manufacturer. (2013, July 15). Rex Plastics.

<https://rexplastics.com/plastic-injection-molds/how-much-do-plastic-injection-molds-cost>

Noxgear Tracer360—Performance Safety Visibility Vest. (n.d.). Retrieved April 30, 2020,

from <https://www.noxgear.com/tracer360>

Periodic Motion | Boundless Physics. (n.d.). Retrieved April 30, 2020, from

<https://courses.lumenlearning.com/boundless-physics/chapter/periodic-motion/>

Spring Constant Formula | Spring Constant Formulas Using Hooke's Law. (n.d.). Retrieved

April 30, 2020, from <https://www.vedantu.com/formula/spring-constant-formula>

Standard Spring Dimension Tolerances for Custom and Stock Springs—Quality Spring,

Affordable Prices. (n.d.). Retrieved April 30, 2020, from

<https://www.acesspring.com/standard-spring-tolerances-for-custom-and-stock-springs.html>

Washers. (n.d.). Retrieved April 30, 2020, from

https://images.homedepot-static.com/productImages/b4291684-6123-4707-ace6-4c3e9381ca87/svn/prime-line-lock-washers-9082419-64_1000.jpg

Wing-nuts. (n.d.). Retrieved April 30, 2020, from

https://images.homedepot-static.com/productImages/c75d2c22-e05e-41c0-a51d-8c558da0946b/svn/wing-nuts-9076681-64_1000.jpg

Appendix A: Tolerances

Part Dimensions and Tolerances Summary

| Part | Parameter | Measurement (inches) | Tolerance (inches) |
|------------|--|----------------------|--------------------|
| Barrel | Length 1 | 2.05 | ± 0.05 |
| | Length 2 | 1 | ± 0.05 |
| | Length 3 | 2.05 | ± 0.05 |
| | Outer diameter (large) | 1.2 | (-0.007, - 0.0105) |
| | Outer diameter (small) | 1 | (-0.007, - 0.0105) |
| | Inner diameter | 0.9 | (-0.000, +0.005) |
| Barrel Cap | Length | 0.05 | ± 0.00025 |
| | Radius | 1.2 | (-0.007, - 0.0105) |
| Casing 1 | Outer Length | 5.9 | ± 0.1 |
| | Inner Length | 5.5 | ± 0.1 |
| | Inner diameter | 1.2 | (-0.000, +0.005) |
| | Thickness | 0.05 | ± 0.00025 |
| | Hole for screws (diameter) | 0.28 | ± 0.0014 |
| Casing 2 | Outer Length | 5.9 | ± 0.1 |
| | Inner Length | 5.5 | ± 0.1 |
| | Thickness | 0.05 | ± 0.00025 |
| | Hole for screws | 0.28 | ± 0.0014 |
| Magnet | Height | 1 | ± 0.0005 |
| | Diameter | 0.85 | (-0.007, - 0.0105) |
| Spring | Wire Diameter | 0.014 | ± 0.0005 |
| | Free Length | 1.014 | ± 0.050 |
| | Small Outer Diameter | 0.152 | ± 0.005 |
| | Large Outer Diameter | 0.18 | ± 0.005 |
| | Solid Height | 0.167 | ± 0.012 |
| Vest | Total Height | 19 | ± 0.005 |
| | Total Length | 12 | ± 0.005 |
| | Total Width | 4 | ± 0.003 |
| | Linear Generator Cloth Casing - Height | 5 | ± 0.003 |

| | | | |
|-------------------------|--|------|---------------|
| | Linear Generator Cloth Casing - Width | 1.3 | ± 0.002 |
| | Linear Generator Cloth Casing - Length | 1.3 | ± 0.002 |
| LED Strip Casing Bottom | Outer diameter | 1 | ± 0.005 |
| | Inner diameter | 0.86 | ± 0.0043 |
| | Length | 0.36 | ± 0.0018 |
| LED Strip Casing Top | Outer diameter (large) | 0.88 | ± 0.0044 |
| | Outer diameter (small) | 0.84 | ± 0.0042 |
| | Inner diameter | 0.15 | ± 0.00075 |
| Circuit Black Box | Diameter | 1 | |
| | Thickness | 0.2 | |

Appendix B: Drawings

Table of Contents

1. Bottom Casing (for Linear Generator)
2. Top Casing (for Linear Generator)
3. Casing Assembly (for Linear Generator)
4. LED Casing Top
5. LED Casing Bottom
6. Magnet
7. Barrel Cap
8. Barrel
9. Linear Generator Assembly

All drawings were produced in Autodesk Inventor 2019.

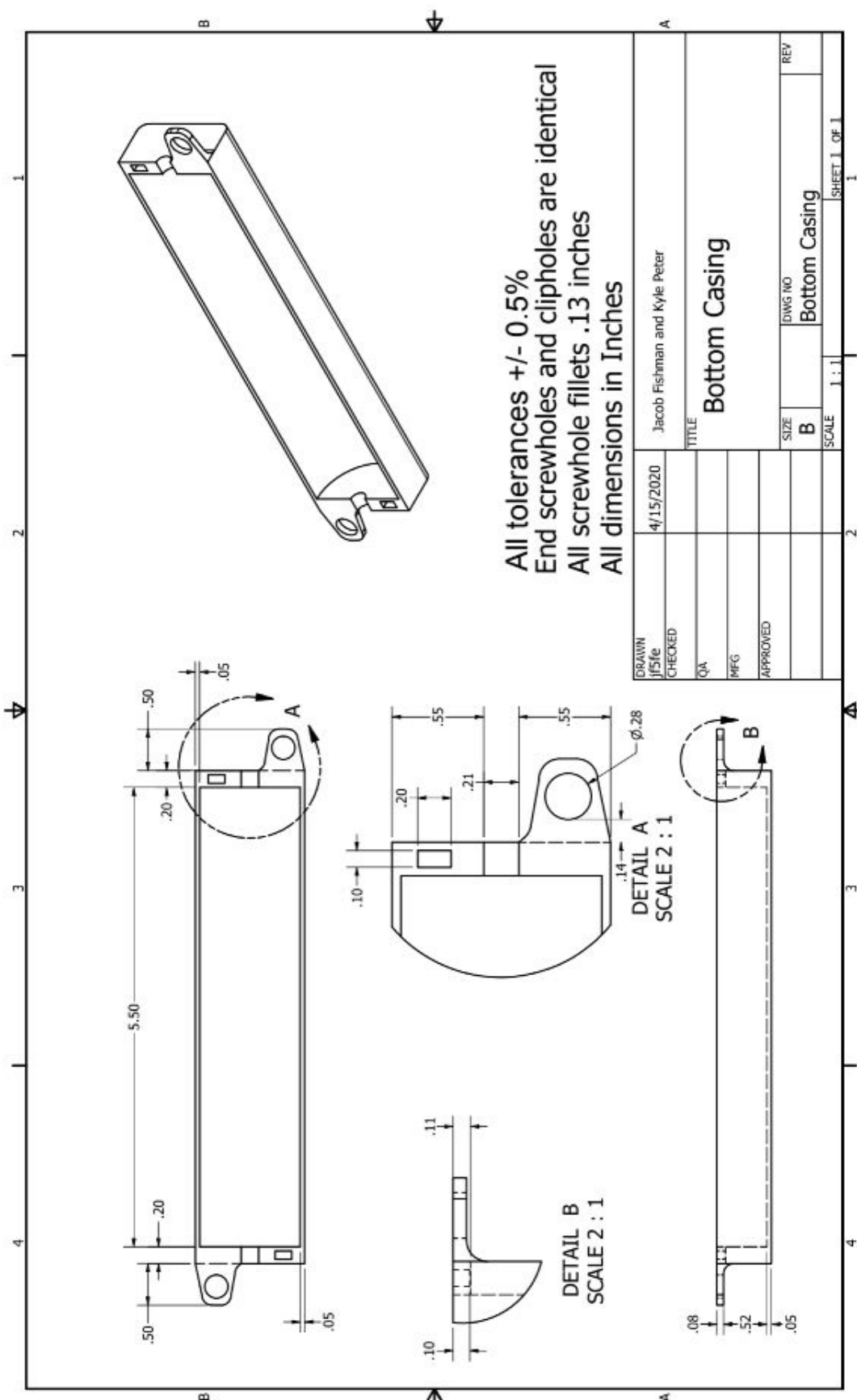

All tolerances +/- 0.5%
 End screwholes and cipholes are identical
 All screwhole fillets .13 inches
 All dimensions in Inches

| | | | |
|-------------------|-----------|------------------------------|-------------------------|
| DESIGNED JF5fe | 4/15/2020 | Jacob Fishman and Kyle Peter | |
| CHECKED | | TITLE Bottom Casing | |
| QA | | SIZE B | DWG NO Bottom Casing |
| MFG | | SCALE 1:1 | REV |
| APPROVED | | | SHEET 1 OF 1 |

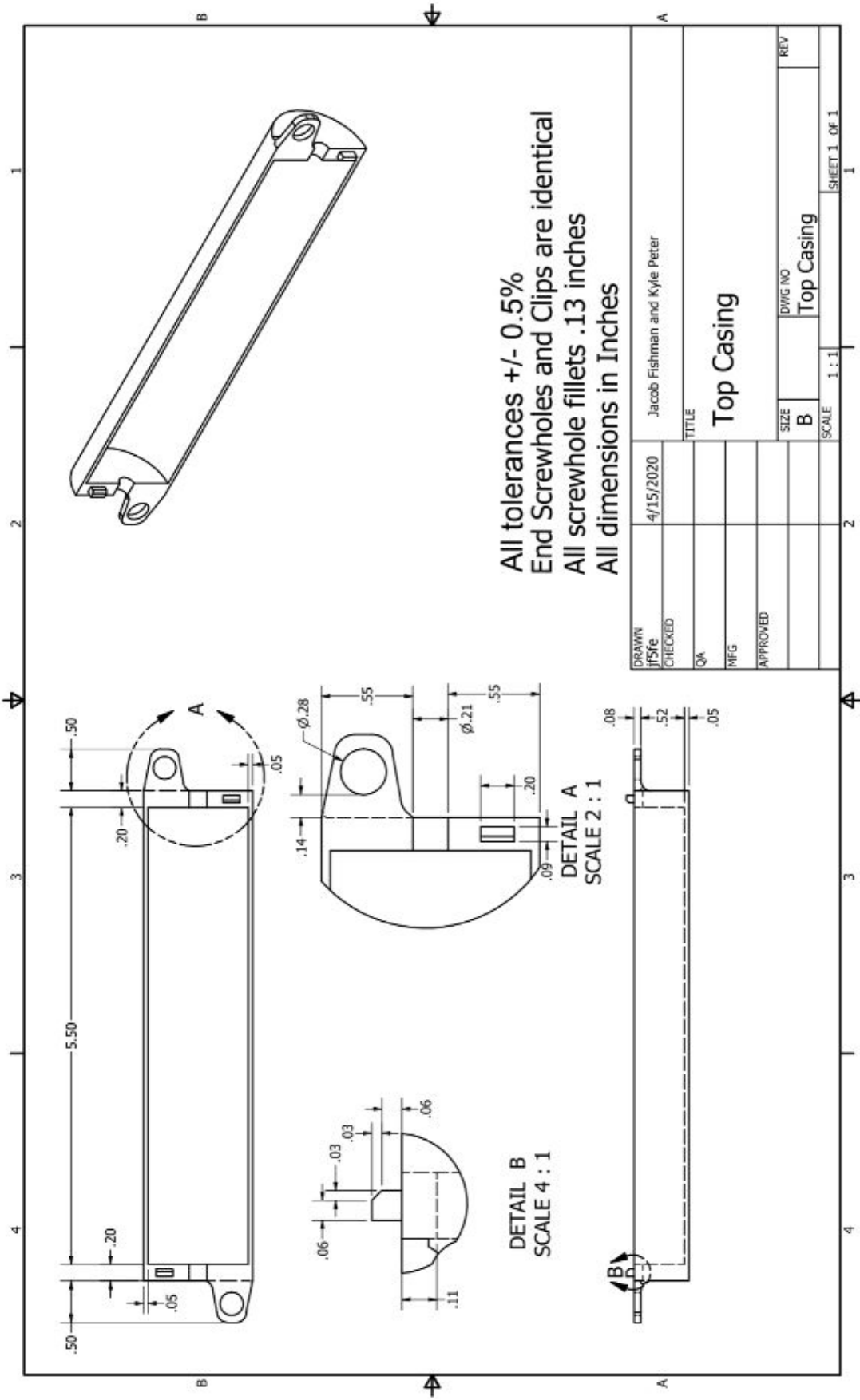

All tolerances +/- 0.5%
 End Screwholes and Clips are identical
 All screwhole fillets .13 inches
 All dimensions in Inches

| | | | | |
|----------------|-----------|------------------------------|--------------|----------------------|
| DRAWN jf5fe | 4/15/2020 | Jacob Fishman and Kyle Peter | TITLE | |
| CHECKED | | | Top Casing | |
| QA | | | SIZE B | DWG NO Top Casing |
| MFG | | | SCALE 1:1 | REV |
| APPROVED | | | | |
| | | | | |
| | | | | |
| | | | | |
| | | | | |

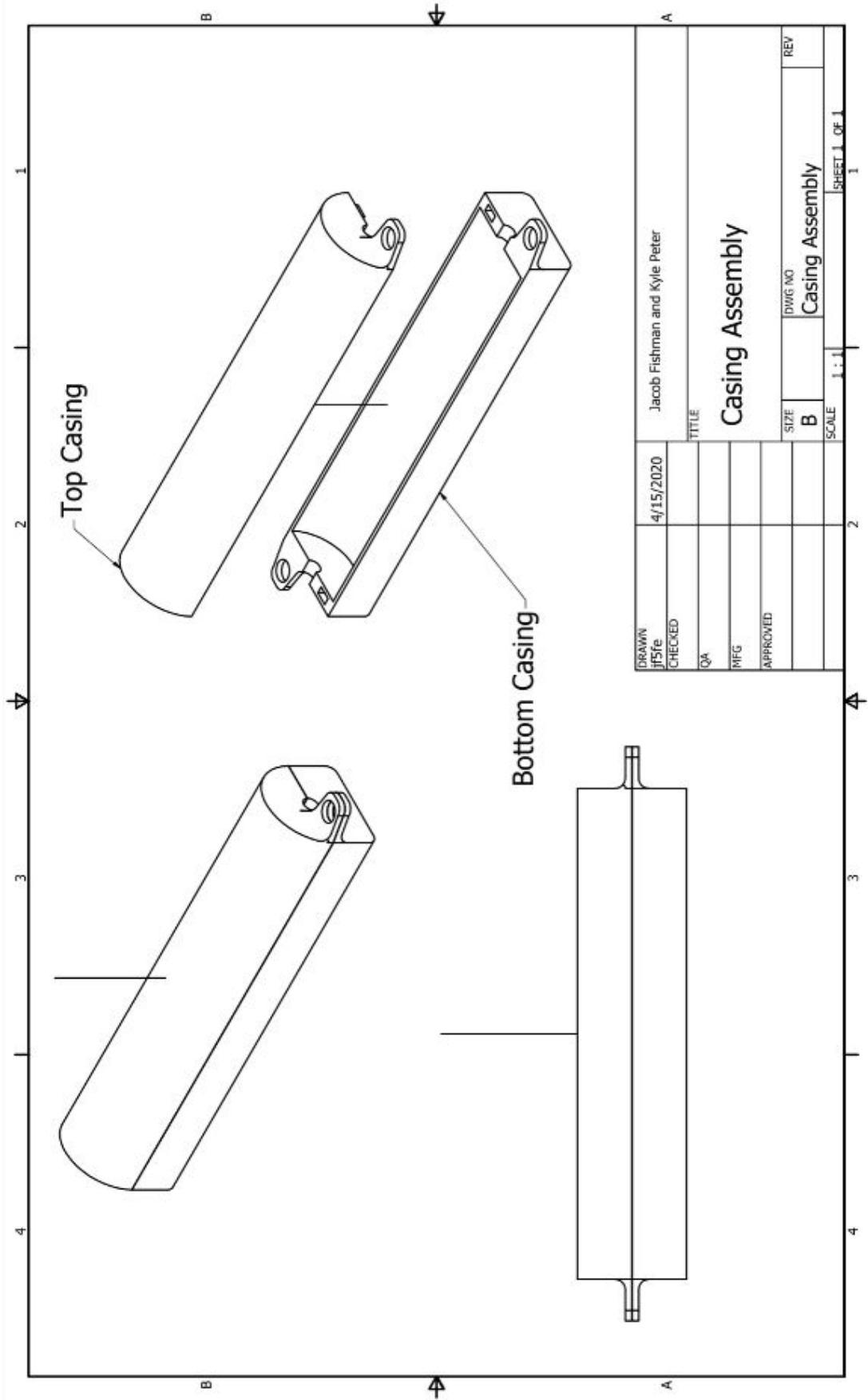

| | | | | |
|----------------|-----------|------------------------------|---------------------------------|--------------|
| DRAWN jf5fe | 4/15/2020 | Jacob Fishman and Kyle Peter | TITLE Casing Assembly | |
| CHECKED | | | DWG NO | REV |
| QA | | | SIZE B | |
| MFG | | | SCALE 1 : 1 | |
| APPROVED | | | | SHEET 1 OF 1 |

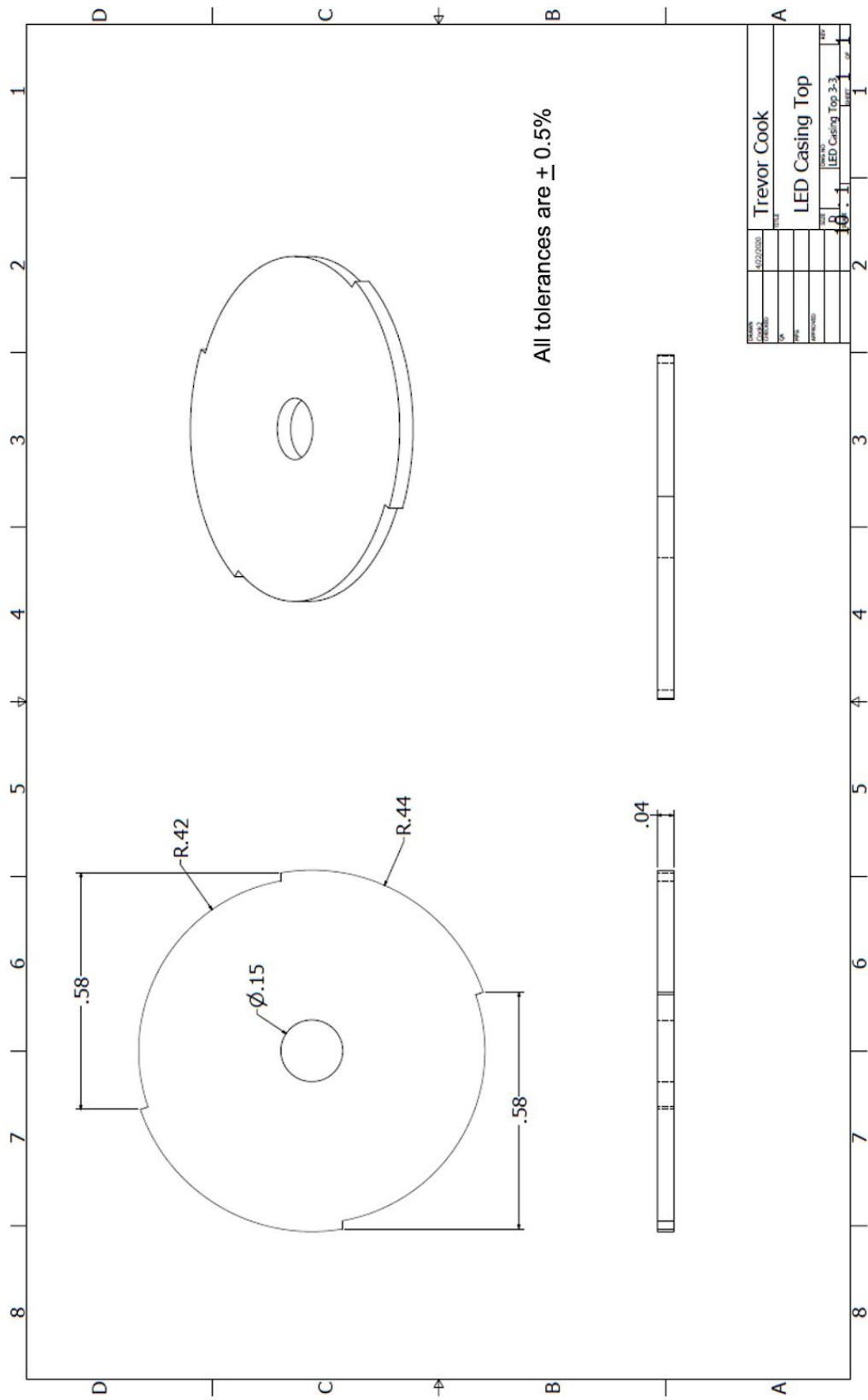

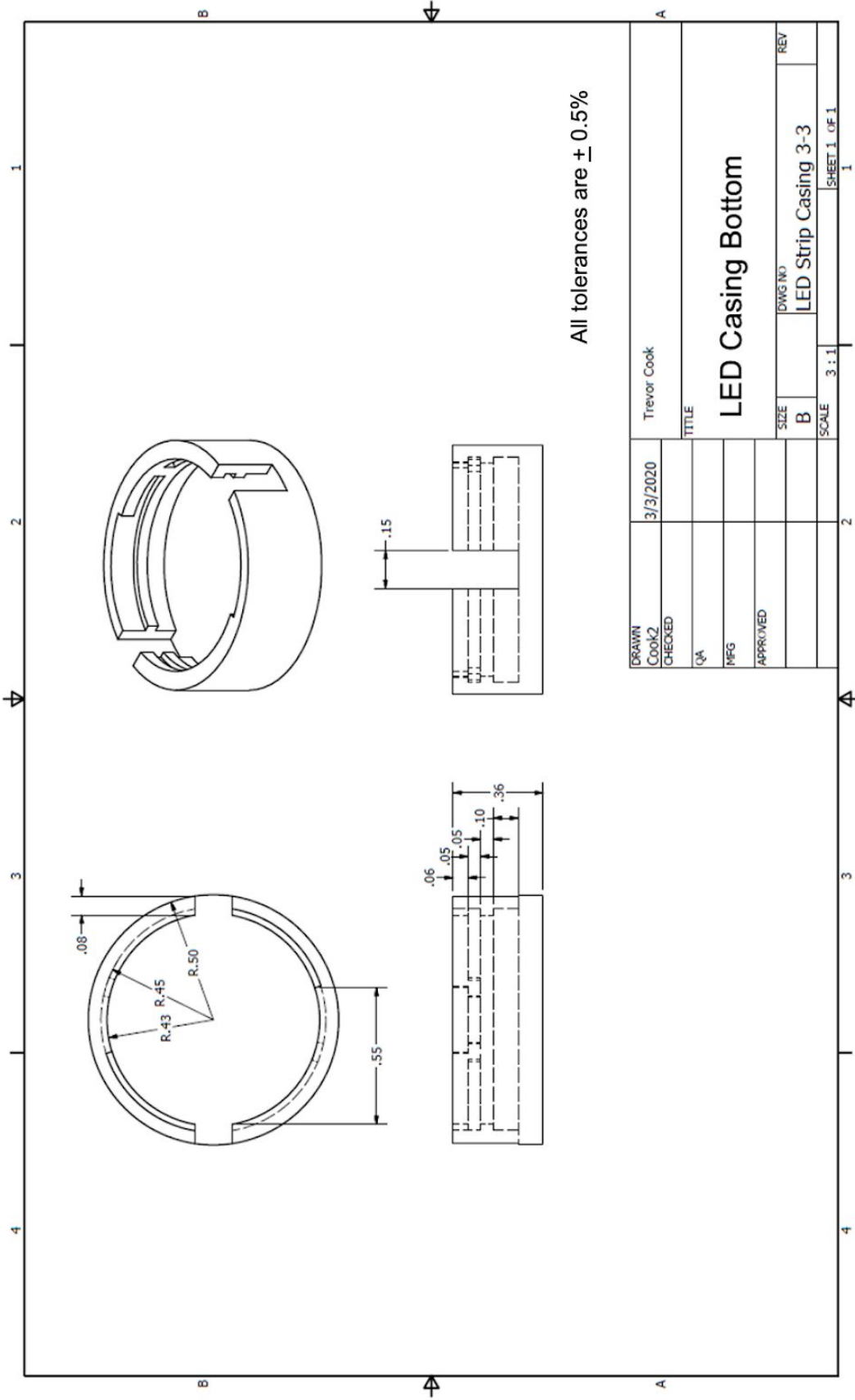

All tolerances are $\pm 0.5\%$

| | | |
|----------------|----------|--------------------------|
| DRAWN Cook2 | 3/3/2020 | Trevor Cook |
| CHECKED | | |
| QA | | TITLE |
| MFG | | LED Casing Bottom |
| APPROVED | | SIZE |
| | | B |
| | | DWG NO. |
| | | LED Strip Casing 3-3 |
| | | REV |
| | | SCALE |
| | | 3 : 1 |
| | | SHEET 1 OF 1 |

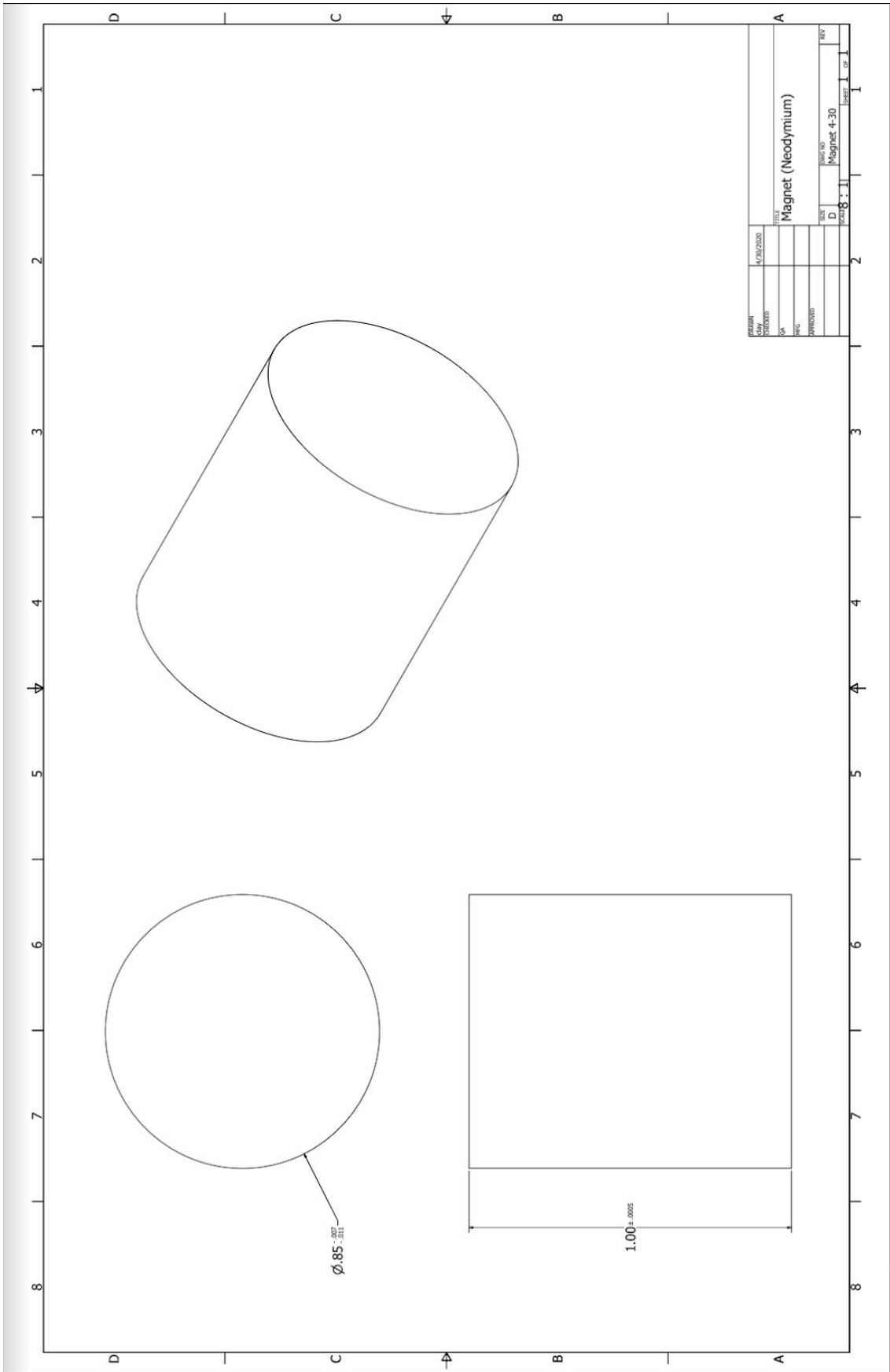

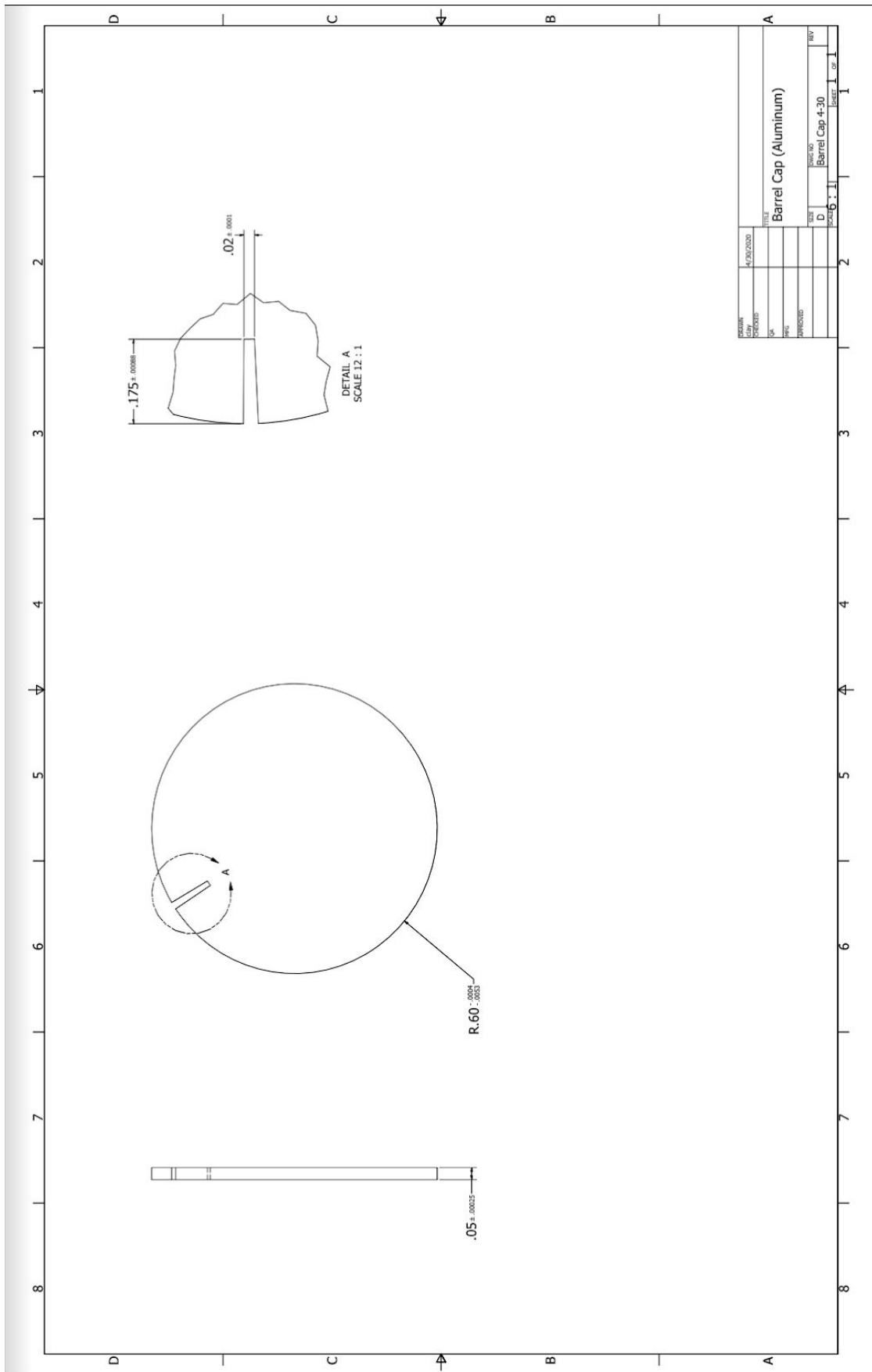

| | | | |
|---------|-----------|-----------------------|---|
| DATE | 4/30/2020 | REV | 1 |
| BY | | REV | 1 |
| CHECKED | | REV | 1 |
| APP | | REV | 1 |
| DATE | 4/30/2020 | REV | 1 |
| TITLE | | Barrel Cap (Aluminum) | |
| PART NO | | Barrel Cap 4-30 | |
| D | | Sheet 1 of 1 | |

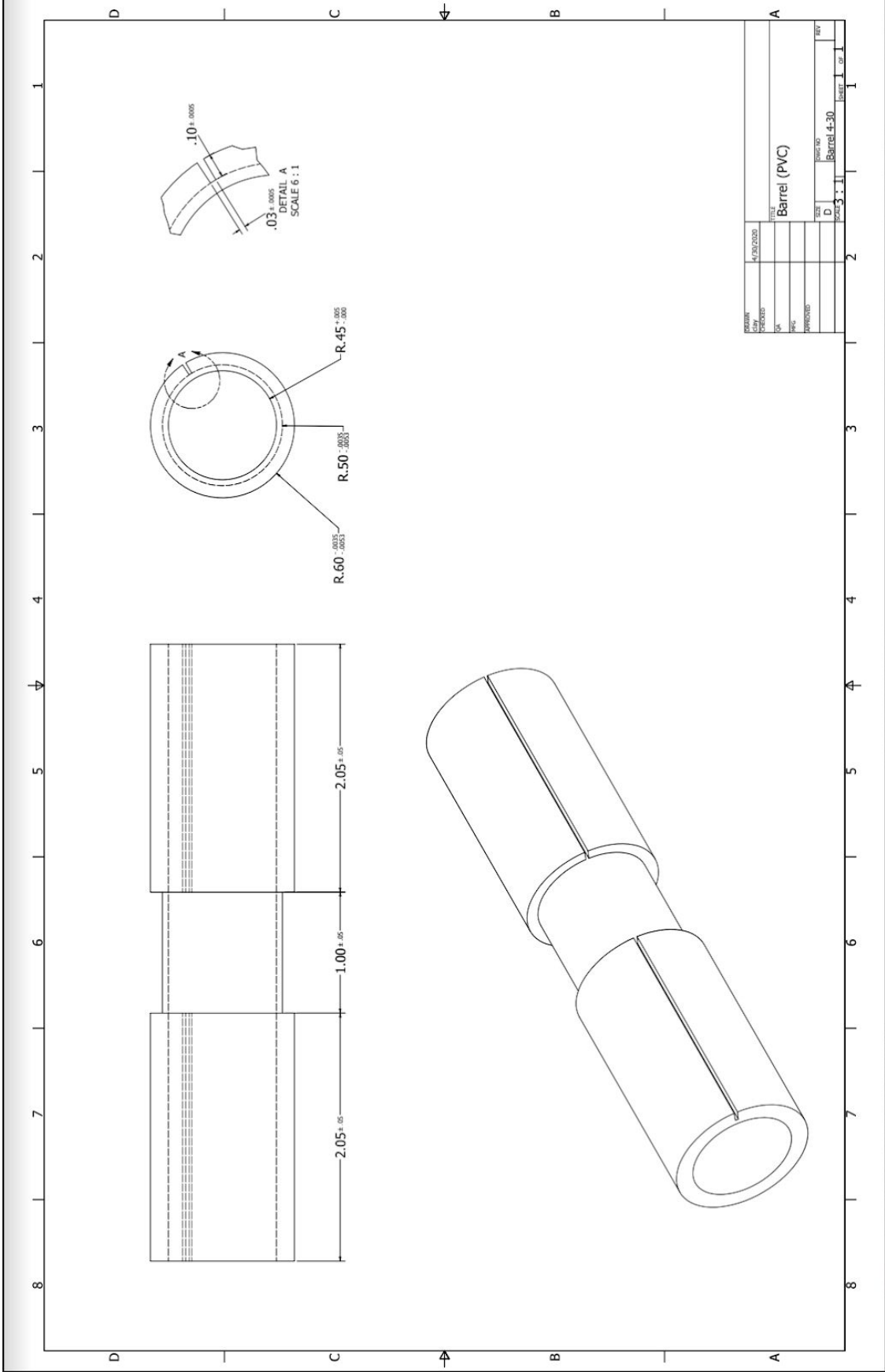

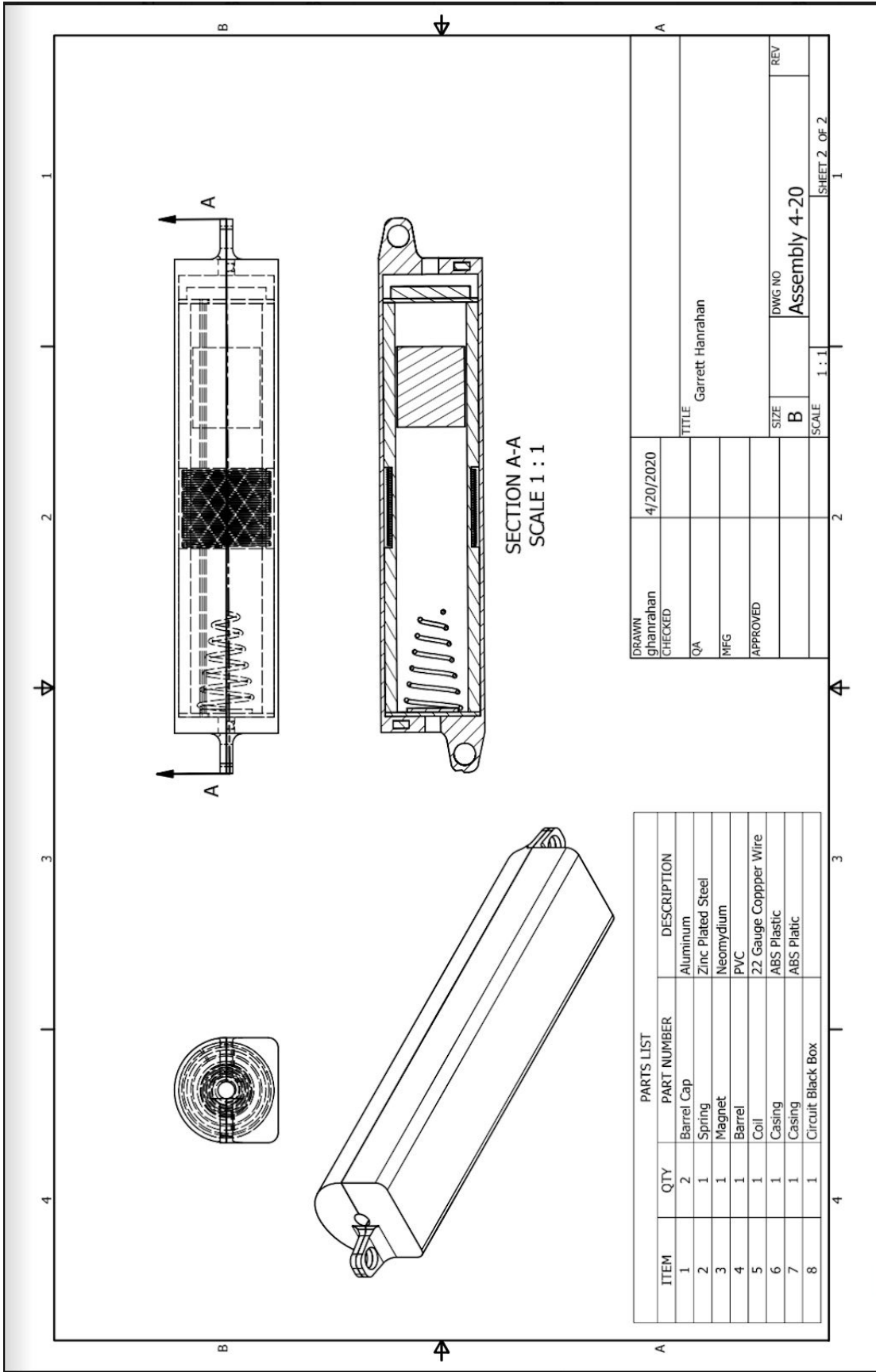

SECTION A-A
SCALE 1 : 1

| ITEM | QTY | PART NUMBER | DESCRIPTION |
|------|-----|-------------------|----------------------|
| 1 | 2 | Barrel Cap | Aluminum |
| 2 | 1 | Spring | Zinc Plated Steel |
| 3 | 1 | Magnet | Neomydium |
| 4 | 1 | Barrel | PVC |
| 5 | 1 | Coil | 22 Gauge Copper Wire |
| 6 | 1 | Casing | ABS Plastic |
| 7 | 1 | Casing | ABS Plastic |
| 8 | 1 | Circuit Black Box | |

| | | |
|--------------------|-----------|---------------------------|
| DRAWN ghanrahan | 4/20/2020 | TITLE Garrett Hanrahan |
| CHECKED | | SIZE B |
| QA | | DWG NO Assembly 4-20 |
| MFG | | REV |
| APPROVED | | SCALE 1 : 1 |
| | | SHEET 2 OF 2 |